

STC 2014 Catalog Valves & Pneumatic Components

Push-In Fittings

SS Push-In & Compression Fittings

Manual & Solenoid Process Valves

Air & Electric Actuated Valves

Filter-Regulator-Lubricator

Solenoid & Air Pilot Valves

Manual Air Valves

Air Cylinders



Fine Quality

S T C™

Advanced Design

Excellent Prices

Precision Engineered



connects *fluid* power to industrial automation™

Website: StcValve.com

Table of Contents

<p>Section A</p>	<p>Composite Push-in Air Fittings</p>	
<p>Section B</p>	<p>Stainless Steel Push-In Fittings Compression Fittings</p>	
<p>Section C</p>	<p>Solenoid Process Valves & Manual Valves</p>	
<p>Section D</p>	<p>Air & Electric Actuated Valves</p>	
<p>Section E</p>	<p>Air Filter-Regulator-Lubricator</p>	
<p>Section F</p>	<p>Solenoid & Air Pilot Directional Valves</p>	
<p>Section G</p>	<p>Manual Air Valves</p>	
<p>Section H</p>	<p>Air Cylinders</p>	

Composite Push-In Fittings

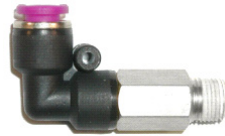
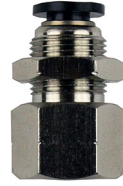

Precision Engineered

Fine Quality



Advanced Design



Excellent Prices



Contents

STC Fittings Numbering System.....	A2
STC Composite Push-In Air Fittings List Price.....	A3-5
STC Miniature Composite Push-In Air Fittings List Price.....	A6
Composite Push-In Fittings Specifications.....	A7
STC Push-In Fittings Dimensions.....	A8-14
STC Composite Angle Flow Control Air Valves Flow Rate.....	A14

STC Fittings Numbering System

Ordering Part No. =
(eg. BC 1/8 10-32)

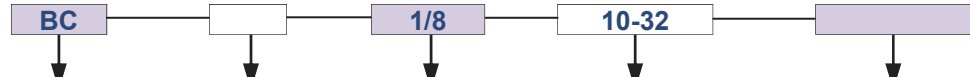







Fitting Name	Model	Material/Type	Tube OD	Thread Size /Stem/Tube	Options
AIR INLINE FLOW CONTROL	AS			THREAD SIZE:	
AIR FLOW CONTROL (panel mount)	ASC			N= NPT	
BRANCH TEE	BT			R=BSPT (British Standard Taper Thread)	
BRASS MUFFLER	BSL			G=BSPP (British Standard Parallel Thread)	
BRASS SPEED CONTROL MUFFLER	BESL			U=Universal thread (fits NPT, R & G)	
BULKHEAD CONNECTOR	BC			10-32	
BULKHEAD UNION	BU			N1/8	
CHECK VALVE	KV			N1/4	
COMPACT MALE CONNECTOR	CC			N3/8	
CONTROL VALVE (meter-in)	CI			N1/2	
CONTROL VALVE (meter-out)	CV				
CROSS UNION	CU		(inch)		
ELBOW REDUCER	ER		1/8		
ELBOW UNION	EU		5/32		
EXTENDED ELBOW	EE		3/16	M5	
FEMALE CONNECTOR	FC		1/4	M6	
FEMALE ELBOW	FE		5/16	R1/8	
FLOW CONTROL VALVE (inline)	FV		3/8	R1/4	
MALE ANGLE	MA		1/2	R3/8	
MALE CONNECTOR	MC			R1/2	
MALE ELBOW	ME	Blank = Composite			
MALE MANIFOLD	MM			G1/8	
MANIFOLD UNION	MU	M = Miniature Composite Fittings		G1/4	
PLUG	PG			G3/8	
PLUG-IN ELBOW	PE		(mm)		
QUICK EXHAUST VALVE	QE		4	U1/8	
REDUCED BRANCH	RB		6	U1/4	
REDUCED ELBOW	RE		8	U3/8	
REDUCED UNION	RU		10	U1/2	
RUN TEE	RT		12		
STACK ELBOW	SE		16		
SHUTTLE VALVE	ST			STEM SIZE:	
STEM COUPLING	SC			1/8-1/2"	
STEM REDUCER	SR			4-12 mm	
STRAIGHT UNION	SU				
TEE UNION	TU				
TEE UNION REDUCER	TU				
TUBE ADAPTOR	TA				
TUBE REDUCER	TR				
UNION VALVE	UV				
UNIVERSAL ELBOW	UE				
Y CONNECTOR	YC				
Y REDUCER	YR				
Y UNION	YU				







Release Button Color
Blank = Purple/Metal Color
K = Black

Composite Push-In Air Fittings List Price



Composite Fittings													
Model		Male Connector with Internal Hex		Compact Male Connector with Internal Hex		Male Elbow		Branch Tee		Run Tee		Y Connector	
Tube OD	Pipe Size	MC		CC		ME		BT		RT		YC	
1/8	10-32UNF	MC 1/8 10-32	\$1.29	CC 1/8 10-32	\$1.29	ME 1/8 10-32	\$1.85	BT 1/8 10-32	\$2.86	RT 1/8 10-32	\$2.61	YC 1/8 10-32	\$2.61
1/8	NPT1/8	MC 1/8 N1/8	\$1.29	CC 1/8 N1/8	\$1.29	ME 1/8 N1/8	\$1.85	BT 1/8 N1/8	\$2.86	RT 1/8 N1/8	\$2.88	YC 1/8 N1/8	\$2.61
1/8	NPT1/4	MC 1/8 N1/4	\$1.29	CC 1/8 N1/4	\$1.29	ME 1/8 N1/4	\$1.85	BT 1/8 N1/4	\$2.86	RT 1/8 N1/4	\$2.88	YC 1/8 N1/4	\$2.61
5/32	10-32UNF	MC 5/32 10-32	\$1.29	CC 5/32 10-32	\$1.37	ME 5/32 10-32	\$1.85	BT 5/32 10-32	\$2.86	RT 5/32 10-32	\$2.61	YC 5/32 10-32	\$2.61
5/32	NPT1/8	MC 5/32 N1/8	\$1.29	CC 5/32 N1/8	\$1.29	ME 5/32 N1/8	\$1.85	BT 5/32 N1/8	\$2.86	RT 5/32 N1/8	\$2.61	YC 5/32 N1/8	\$2.61
5/32	NPT1/4	MC 5/32 N1/4	\$1.31	CC 5/32 N1/4	\$1.29	ME 5/32 N1/4	\$1.85	BT 5/32 N1/4	\$2.86	RT 5/32 N1/4	\$2.88	YC 5/32 N1/4	\$2.61
3/16	10-32UNF	MC 3/16 10-32	\$1.29	CC 3/16 10-32	\$1.29	ME 3/16 10-32	\$1.85	BT 3/16 10-32	\$2.86	RT 3/16 10-32	\$2.88	YC 3/16 10-32	\$2.88
3/16	NPT1/8	MC 3/16 N1/8	\$1.29	CC 3/16 N1/8	\$1.29	ME 3/16 N1/8	\$1.85	BT 3/16 N1/8	\$2.86	RT 3/16 N1/8	\$2.88	YC 3/16 N1/8	\$2.88
3/16	NPT1/4	MC 3/16 N1/4	\$1.29	CC 3/16 N1/4	\$1.29	ME 3/16 N1/4	\$1.85	BT 3/16 N1/4	\$2.86	RT 3/16 N1/4	\$2.88	YC 3/16 N1/4	\$2.88
3/16	NPT3/8	MC 3/16 N3/8	\$1.29	CC 3/16 N3/8	\$1.29	ME 3/16 N3/8	\$1.85	BT 3/16 N3/8	\$2.86	RT 3/16 N3/8	\$2.88	YC 3/16 N3/8	\$2.88
1/4	10-32UNF	MC 1/4 10-32	\$1.29	CC 1/4 10-32	\$1.43	ME 1/4 10-32	\$1.85	BT 1/4 10-32	\$2.86	RT 1/4 10-32	\$3.46	YC 1/4 10-32	\$2.88
1/4	NPT1/8	MC 1/4 N1/8	\$1.29	CC 1/4 N1/8	\$1.61	ME 1/4 N1/8	\$1.85	BT 1/4 N1/8	\$2.89	RT 1/4 N1/8	\$3.94	YC 1/4 N1/8	\$2.88
1/4	NPT1/4	MC 1/4 N1/4	\$1.37	CC 1/4 N1/4	\$1.32	ME 1/4 N1/4	\$1.85	BT 1/4 N1/4	\$3.12	RT 1/4 N1/4	\$3.94	YC 1/4 N1/4	\$3.11
1/4	NPT3/8	MC 1/4 N3/8	\$1.85	CC 1/4 N3/8	\$2.75	ME 1/4 N3/8	\$2.20	BT 1/4 N3/8	\$3.46	RT 1/4 N3/8	\$4.31	YC 1/4 N3/8	\$3.46
5/16	NPT1/8	MC 5/16 N1/8	\$1.37	CC 5/16 N1/8	\$1.32	ME 5/16 N1/8	\$2.05	BT 5/16 N1/8	\$3.25	RT 5/16 N1/8	\$3.59	YC 5/16 N1/8	\$3.25
5/16	NPT1/4	MC 5/16 N1/4	\$1.43	CC 5/16 N1/4	\$1.29	ME 5/16 N1/4	\$2.05	BT 5/16 N1/4	\$3.25	RT 5/16 N1/4	\$3.94	YC 5/16 N1/4	\$3.25
5/16	NPT3/8	MC 5/16 N3/8	\$1.85	CC 5/16 N3/8	\$1.85	ME 5/16 N3/8	\$2.34	BT 5/16 N3/8	\$3.59	RT 5/16 N3/8	\$4.31	YC 5/16 N3/8	\$3.59
3/8	NPT1/8	MC 3/8 N1/8	\$1.91	CC 3/8 N1/8	\$2.75	ME 3/8 N1/8	\$2.49	BT 3/8 N1/8	\$3.46	RT 3/8 N1/8	\$4.31	YC 3/8 N1/8	\$3.59
3/8	NPT1/4	MC 3/8 N1/4	\$1.99	CC 3/8 N1/4	\$1.92	ME 3/8 N1/4	\$2.49	BT 3/8 N1/4	\$3.61	RT 3/8 N1/4	\$4.31	YC 3/8 N1/4	\$3.59
3/8	NPT3/8	MC 3/8 N3/8	\$2.75	CC 3/8 N3/8	\$2.75	ME 3/8 N3/8	\$2.93	BT 3/8 N3/8	\$3.88	RT 3/8 N3/8	\$4.64	YC 3/8 N3/8	\$3.81
3/8	NPT1/2	MC 3/8 N1/2	\$2.86	CC 3/8 N1/2	\$2.75	ME 3/8 N1/2	\$4.25	BT 3/8 N1/2	\$5.03	RT 3/8 N1/2	\$5.02	YC 3/8 N1/2	\$4.64
1/2	NPT1/4	MC 1/2 N1/4	\$2.75	CC 1/2 N1/4	\$3.71	ME 1/2 N1/4	\$4.25	BT 1/2 N1/4	\$4.64	RT 1/2 N1/4	\$4.64	YC 1/2 N1/4	\$4.64
1/2	NPT3/8	MC 1/2 N3/8	\$2.75	CC 1/2 N 3/8	\$3.78	ME 1/2 N3/8	\$4.25	BT 1/2 N3/8	\$4.74	RT 1/2 N3/8	\$5.03	YC 1/2 N3/8	\$4.64
1/2	NPT1/2	MC 1/2 N1/2	\$3.17	CC 1/2 N1/2	\$3.90	ME 1/2 N1/2	\$4.25	BT 1/2 N1/2	\$5.23	RT 1/2 N1/2	\$5.36	YC 1/2 N1/2	\$5.02
4 mm	M5X0.8	MC 4 M5	\$1.29			ME 4 M5	\$1.85	BT 4 M5	\$2.61	RT 4 M5	\$2.61	YC 4 M5	\$2.61
4 mm	M6X1	MC 4 M6	\$1.29			ME 4 M6	\$1.85	BT 4 M6	\$2.61	RT 4 M6	\$2.61	YC 4 M6	\$2.61
4 mm	R1/8	MC 4 R1/8	\$1.29			ME 4 R1/8	\$1.85	BT 4 R1/8	\$2.86	RT 4 R1/8	\$2.61	YC 4 R1/8	\$2.61
4 mm	R1/4	MC 4 R1/4	\$1.29			ME 4 R1/4	\$1.85	BT 4 R1/4	\$2.86	RT 4 R1/4	\$2.86	YC 4 R1/4	\$2.86
6 mm	M5X0.8	MC 6 M5	\$1.29			ME 6 M5	\$1.85	BT 6 M5	\$2.88	RT 6 M5	\$3.46	YC 6 M5	\$2.88
6 mm	M6X1	MC 6 M6	\$1.29			ME 6 M6	\$1.85	BT 6 M6	\$2.88	RT 6 M6	\$3.46	YC 6 M6	\$2.88
6 mm	R1/8	MC 6 R1/8	\$1.29			ME 6 R1/8	\$1.85	BT 6 R1/8	\$2.86	RT 6 R1/8	\$3.46	YC 6 R1/8	\$2.88
6 mm	R1/4	MC 6 R1/4	\$1.29			ME 6 R1/4	\$1.85	BT 6 R1/4	\$3.11	RT 6 R1/4	\$3.94	YC 6 R1/4	\$3.11
6 mm	R3/8	MC 6 R3/8	\$1.85			ME 6 R3/8	\$2.20	BT 6 R3/8	\$3.46	RT 6 R3/8	\$4.31	YC 6 R3/8	\$3.46
6 mm	R1/2	MC 6 R1/2	\$2.55			ME 6 R1/2	\$3.63	BT 6 R1/2	\$4.64	RT 6 R1/2	\$5.02	YC 6 R1/2	\$4.64
8 mm	R1/8	MC 8 R1/8	\$1.29			ME 8 R1/8	\$2.05	BT 8 R1/8	\$3.25	RT 8 R1/8	\$3.59	YC 8 R1/8	\$3.25
8 mm	R1/4	MC 8 R1/4	\$1.29			ME 8 R1/4	\$2.05	BT 8 R1/4	\$3.25	RT 8 R1/4	\$3.94	YC 8 R1/4	\$3.25
8 mm	R3/8	MC 8 R3/8	\$1.29			ME 8 R3/8	\$2.05	BT 8 R3/8	\$3.59	RT 8 R3/8	\$4.31	YC 8 R3/8	\$3.59
8 mm	R1/2	MC 8 R1/2	\$2.58			ME 8 R1/2	\$2.34	BT 8 R1/2	\$3.59	RT 8 R1/2	\$5.02	YC 8 R1/2	\$4.60
10 mm	R1/8	MC 10 R1/8	\$1.91			ME 10 R1/8	\$2.34	BT 10 R1/8	\$3.46	RT 10 R1/8	\$4.31	YC 10 R1/8	\$3.59
10 mm	R1/4	MC 10 R1/4	\$1.91			ME 10 R1/4	\$2.34	BT 10 R1/4	\$3.59	RT 10 R1/4	\$4.31	YC 10 R1/4	\$3.59
10 mm	R3/8	MC 10 R3/8	\$2.73			ME 10 R3/8	\$2.93	BT 10 R3/8	\$3.87	RT 10 R3/8	\$4.60	YC 10 R3/8	\$3.81
10 mm	R1/2	MC 10 R1/2	\$2.73			ME 10 R1/2	\$4.25	BT 10 R1/2	\$5.02	RT 10 R1/2	\$5.02	YC 10 R1/2	\$4.64
12 mm	R 1/8	MC 12 R1/8	\$1.87										
12 mm	R1/4	MC 12 R1/4	\$2.73			ME 12 R1/4	\$4.25	BT 12 R1/4	\$4.64	RT 12 R1/4	\$4.64	YC 12 R1/4	\$4.64
12 mm	R3/8	MC 12 R3/8	\$2.73			ME 12 R3/8	\$4.25	BT 12 R3/8	\$4.64	RT 12 R3/8	\$5.02	YC 12 R3/8	\$4.64
12 mm	R1/2	MC 12 R1/2	\$2.80			ME 12 R1/2	\$4.25	BT 12 R1/2	\$5.02	RT 12 R1/2	\$5.36	YC 12 R1/2	\$5.02







Composite Push-In Air Fittings List Price



Composite Fittings															
Model		Universal Elbow		Extended Elbow		Female Connector		Female Elbow		Bulkhead Connector		Flow Control Valve meter-out		Flow Control Valve meter-in	
Tube OD	Pipe Size	UE		EE		FC		FE		BC		CV		CI	
1/8	10-32UNF	UE 1/8 10-32	\$2.88			FC 1/8 10-32	\$1.62	FE 1/8 10-32	\$2.31			CV 1/8 10-32	\$7.11	CI 1/8 10-32	
1/8	NPT1/8	UE 1/8 N1/8	\$2.88			FC 1/8 N1/8	\$1.62	FE 1/8 N1/8	\$2.31	BC 1/8 N1/8	\$3.05	CV 1/8 N1/8	\$7.11	CI 1/8 N1/8	\$8.27
5/32	10-32UNF	UE 5/32 10-32	\$2.88	EE 5/32 10-32	\$2.31	FC 5/32 10-32	\$1.62	FE 5/32 10-32	\$2.31		\$0.00	CV 5/32 10-32	\$7.11	CI 5/32 10-32	\$8.27
5/32	NPT1/8	UE 5/32 N1/8	\$2.88	EE 5/32 N1/8	\$2.31	FC 5/32 N1/8	\$1.62	FE 5/32 N1/8	\$2.31	BC 5/32 N1/8	\$3.06	CV 5/32 N1/8	\$7.11	CI 5/32 N1/8	
5/32	NPT1/4					FC 5/32 N1/4	\$1.62	FE 5/32 N1/4	\$2.31	BC 5/32 N1/4	\$3.06	CV 5/32 N1/4	\$7.11	CI 5/32 N1/4	
3/16	10-32UNF	UE 3/16 10-32	\$3.46					FE 3/16 10-32	\$2.31						
3/16	NPT1/8	UE 3/16 N1/8		EE 3/16 N1/8	\$2.31			FE 3/16 N1/8	\$2.31	BC 3/16 N1/8	\$3.05	CV 3/16 N1/8	\$7.11		
3/16	NPT1/4	UE 3/16 N1/4	\$3.46	EE 3/16 N1/4	\$2.31			FE 3/16 N1/4	\$2.31	BC 3/16 N1/4	\$3.05				
3/16	NPT3/8		\$0.00	EE 3/16 N3/8	\$2.92										
1/4	10-32UNF	UE 1/4 10-32	\$3.46					FE 1/4 10-32	\$2.31			CV 1/4 10-32	\$7.11	CI 1/4 10-32	\$8.27
1/4	NPT1/8	UE 1/4 N1/8	\$3.46	EE 1/4 N1/8	\$2.31	FC 1/4 N1/8	\$1.62	FE 1/4 N1/8	\$2.31	BC 1/4 N1/8	\$3.66	CV 1/4 N1/8	\$7.68	CI 1/4 N1/8	\$8.83
1/4	NPT1/4	UE 1/4 N1/4	\$3.94	EE 1/4 N1/4	\$2.31	FC 1/4 N1/4	\$1.92	FE 1/4 N1/4	\$2.49	BC 1/4 N1/4	\$4.17	CV 1/4 N1/4	\$7.68	CI 1/4 N1/4	\$8.83
1/4	NPT3/8		\$0.00	EE 1/4 N3/8	\$2.92			FE 1/4 N3/8	\$2.92			CV 1/4 N3/8	\$9.80		
5/16	NPT1/8	UE 5/16 N1/8	\$3.59	EE 5/16 N1/8	\$2.48	FC 5/16 N1/8	\$1.85	FE 5/16 N1/8	\$2.49	BC 5/16 N1/8	\$3.80	CV 5/16 N1/8	\$7.68	CI 5/16 N1/8	\$8.83
5/16	NPT1/4	UE 5/16 N1/4	\$3.59	EE 5/16 N1/4	\$2.48	FC 5/16 N1/4	\$2.17	FE 5/16 N1/4	\$2.49	BC 5/16 N1/4	\$4.17	CV 5/16 N1/4	\$7.68		
5/16	NPT3/8	UE 5/16 N3/8	\$4.31	EE 5/16 N3/8	\$2.73	FC 5/16 N3/8	\$2.19	FE 5/16 N3/8	\$2.73			CV 5/16 N3/8	\$9.80		
3/8	NPT1/8	UE 3/8 N1/8	\$4.31												
3/8	NPT1/4	UE 3/8 N1/4	\$4.31	EE 3/8 N1/4	\$3.44	FC 3/8 N1/4	\$2.47	FE 3/8 N1/4	\$3.44	BC 3/8 N1/4	\$4.72	CV 3/8 N1/4	\$8.38	CI 3/8 N1/4	\$9.53
3/8	NPT3/8	UE 3/8 N3/8	\$4.64	EE 3/8 N3/8	\$3.44	FC 3/8 N3/8	\$3.17	FE 3/8 N3/8	\$3.44	BC 3/8 N3/8	\$5.00	CV 3/8 N3/8	\$9.80	CI 3/8 N3/8	
3/8	NPT1/2			EE 3/8 N1/2	\$5.14	FC 3/8 N1/2		FE 3/8 N1/2				CV 3/8 N1/2		CI 3/8 N1/2	
1/2	NPT1/4	UE 1/2 N1/4	\$5.02	EE 1/2 N1/4	\$5.14	FC 1/2 N1/4	\$3.74								
1/2	NPT3/8	UE 1/2 N3/8	\$5.02	EE 1/2 N3/8	\$5.14	FC 1/2 N3/8	\$3.74			BC 1/2 N3/8	\$5.65	CV 1/2 N3/8	\$11.20	CI 1/2 N3/8	\$12.35
1/2	NPT1/2	UE 1/2 N1/2	\$5.35	EE 1/2 N1/2	\$6.14					BC 1/2 N1/2	\$5.65	CV 1/2 N1/2	\$11.82	CI 1/2 N1/2	\$12.85
4 mm	M5X0.8	UE 4 M5	\$2.88	EE 4 M5	\$2.31			FE 4 M5	\$2.31			CV 4 M5	\$7.11	CI 4 M5	
4 mm	M6X1	UE 4 M6	\$2.88	EE 4 M6	\$2.31			FE 4 M6	\$2.31			CV 4 M6	\$7.11	CI 4 M6	
4 mm	R1/8	UE 4 R1/8	\$2.88	EE 4 R1/8	\$2.31	FC 4 R1/8	\$1.62	FE 4 R1/8	\$2.31	BC 4 R1/8	\$3.05	CV 4 R1/8	\$7.11	CI 4 R1/8	
4 mm	R1/4	UE 4 R1/4	\$3.46	EE 4 R1/4	\$2.31	FC 4 R1/4	\$1.62	FE 4 R1/4	\$2.31	BC 4 R1/4	\$3.05	CV 4 R1/4	\$7.68	CI 4 R1/4	
6 mm	M5X0.8	UE 6 M5	\$3.46	EE 6 M5	\$2.31			FE 6 M5	\$2.31			CV 6 M5	\$7.11	CI 6 M5	
6 mm	M6X1	UE 6 M6	\$3.46	EE 6 M6	\$2.31			FE 6 M6	\$2.31			CV 6 M6	\$7.11	CI 6 M6	
6 mm	R1/8	UE 6 R1/8	\$3.46	EE 6 R1/8	\$2.31	FC 6 R1/8	\$1.62	FE 6 R1/8	\$2.31	BC 6 R1/8	\$3.66	CV 6 R1/8	\$7.68	CI 6 R1/8	\$8.83
6 mm	R1/4	UE 6 R1/4	\$3.94	EE 6 R1/4	\$2.31	FC 6 R1/4	\$1.83	FE 6 R1/4	\$2.31	BC 6 R1/4	\$4.17	CV 6 R1/4	\$7.68	CI 6 R1/4	
6 mm	R3/8	UE 6 R3/8	\$4.31	EE 6 R3/8	\$2.92	FC 6 R3/8	\$2.19	FE 6 R3/8	\$2.92	BC 6 R3/8	\$4.56	CV 6 R3/8	\$9.80	CI 6 R3/8	
6 mm	R1/2			EE 6 R1/2	\$4.56										
8 mm	R1/8	UE 8 R1/8	\$3.59	EE 8 R1/8	\$2.48	FC 8 R1/8	\$1.85	FE 8 R1/8	\$2.48	BC 8 R1/8	\$3.80	CV 8 R1/8	\$7.68	CI 8 R1/8	
8 mm	R1/4	UE 8 R1/4	\$3.59	EE 8 R1/4	\$2.48	FC 8 R1/4	\$1.85	FE 8 R1/4	\$2.48	BC 8 R1/4	\$4.17	CV 8 R1/4	\$7.68	CI 8 R1/4	
8 mm	R3/8	UE 8 R3/8	\$4.31	EE 8 R3/8	\$2.92	FC 8 R3/8	\$2.19	FE 8 R3/8	\$2.73	BC 8 R3/8	\$4.56	CV 8 R3/8	\$9.80	CI 8 R3/8	\$11.39
8 mm	R1/2	UE 8 R1/2	\$5.02	EE 8 R1/2	\$4.56	FC 8 R1/2	\$3.59			BC 8 R1/2	\$5.27	CV 8 R1/2	\$9.80	CI 8 R1/2	
10 mm	R1/8			EE 10 R1/8	\$3.44	FC 10 R1/8	\$2.47	FE 10 R1/8	\$3.44	BC 10 R1/8	\$4.17				
10 mm	R1/4	UE 10 R1/4	\$4.31	EE 10 R1/4	\$3.44	FC 10 R1/4	\$2.47	FE 10 R1/4	\$3.44	BC 10 R1/4	\$4.56	CV 10 R1/4	\$8.39	CI 10 R1/4	
10 mm	R3/8	UE 10 R3/8	\$4.64	EE 10 R3/8	\$3.44	FC 10 R3/8	\$2.47	FE 10 R3/8	\$3.44	BC 10 R3/8	\$4.91	CV 10 R3/8	\$9.80	CI 10 R3/8	
10 mm	R1/2	UE 10 R1/2	\$5.02	EE 10 R1/2	\$5.14	FC 10 R1/2	\$3.74	FE 10 R1/2	\$5.14	BC 10 R1/2	\$5.27	CV 10 R1/2	\$11.69	CI 10 R1/2	
12 mm	R1/4	UE 12 R1/4	\$5.02	EE 12 R1/4	\$5.14	FC 12 R1/4	\$3.74	FE 12 R1/4	\$5.14	BC 12 R1/4	\$4.91	CV 12 R1/4	\$11.20	CI 12 R1/4	
12 mm	R3/8	UE 12 R3/8	\$5.02	EE 12 R3/8	\$5.14	FC 12 R3/8	\$3.74	FE 12 R3/8	\$5.14	BC 12 R3/8	\$5.27	CV 12 R3/8	\$11.20	CI 12 R3/8	
12 mm	R1/2	UE 12 R1/2	\$5.36	EE 12 R1/2	\$5.14	FC 12 R1/2	\$3.74	FE 12 R1/2	\$5.14	BC 12 R1/2	\$5.65	CV 12 R1/2	\$11.69	CI 12 R1/2	

Composite Push-In Air Fittings List Price



														
Model	Flow Valve		Bulkhead Union		Cross Union		Elbow Union		Straight Union		Tee Union		Y Union	
Tube OD	FV		BU		CU		EU		SU		TU		YU	
1/8	FV 1/8	\$8.25	BU 1/8	\$3.00	CU 1/8	\$3.54	EU 1/8	\$1.53	SU 1/8	\$1.53	TU 1/8	\$2.26	YU 1/8	\$2.26
5/32	FV 5/32	\$8.25	BU 5/32	\$3.00	CU 5/32	\$3.54	EU 5/32	\$1.53	SU 5/32	\$1.53	TU 5/32	\$2.26	YU 5/32	\$2.26
3/16	FV 3/16	\$8.25	BU 3/16	\$3.00	CU 3/16	\$3.54	EU 3/16	\$1.53	SU 3/16	\$1.53	TU 3/16	\$2.26	YU 3/16	\$2.26
1/4	FV 1/4	\$8.50	BU 1/4	\$3.00	CU 1/4	\$3.54	EU 1/4	\$1.60	SU 1/4	\$1.60	TU 1/4	\$2.26	YU 1/4	\$2.26
5/16	FV 5/16	\$8.50	BU 5/16	\$3.63	CU 5/16	\$3.54	EU 5/16	\$1.87	SU 5/16	\$1.83	TU 5/16	\$2.26	YU 5/16	\$2.26
3/8	FV 3/8	\$9.45	BU 3/8	\$4.39	CU 3/8	\$4.43	EU 3/8	\$2.12	SU 3/8	\$2.12	TU 3/8	\$2.81	YU 3/8	\$2.81
1/2	FV 1/2	\$13.11	BU 1/2	\$4.51	CU 1/2	\$5.49	EU 1/2	\$2.48	SU 1/2	\$2.47	TU 1/2	\$3.52	YU 1/2	\$3.52
4 mm	FV 04	\$8.50	BU 4	\$3.00	CU 4	\$3.54	EU 4	\$1.53	SU 4	\$1.53	TU 4	\$2.26	YU 4	\$2.26
6 mm	FV 06	\$8.50	BU 6	\$3.00	CU 6	\$3.54	EU 6	\$1.60	SU 6	\$1.60	TU 6	\$2.26	YU 6	\$2.26
8 mm	FV 08	\$8.61	BU 8	\$3.63	CU 8	\$4.43	EU 8	\$1.84	SU 8	\$1.83	TU 8	\$2.26	YU 8	\$2.26
10 mm	FV 10	\$12.43	BU 10	\$4.39	CU 10	\$5.24	EU 10	\$2.12	SU 10	\$2.12	TU 10	\$2.81	YU 10	\$2.81
12 mm	FV 12	\$13.81	BU 12	\$4.51	CU 12	\$5.49	EU 12	\$2.47	SU 12	\$2.47	TU 12	\$3.52	YU 12	\$3.52
Composite Fittings														
Model	Elbow Reducer (Tube-Stem)		Plug In Elbow		Male Manifold		Manifold Union		Reduced Branch		Reduced Union		Tee Union Reducer	
Tube OD	ER		PE		MM		MU		RB		RU		TU	
1/8	ER 1/8-5/32	\$2.95	PE 1/8	\$2.13	MM 1/4-5/32-N1/8	\$5.07	MU 5/32X1/8	\$4.57	RB 5/32-1/8	\$2.95	RU 5/32-1/8	\$1.83	TU 5/32-1/8	\$2.95
5/32	ER 5/32-1/4	\$2.95	PE 5/32	\$2.13	MM 5/16-5/32-N1/4	\$5.20	MU 1/4X5/32	\$4.57	RB 3/16-5/32	\$2.95	RU 3/16-5/32	\$1.83		
3/16					MM 5/16-1/4-N1/4	\$5.20	MU 5/16X5/32	\$4.57	RB 1/4-5/32	\$2.95	RU 1/4-5/32	\$1.83	TU 1/4-5/32	\$2.95
1/4	ER 1/4-5/16	\$2.95	PE 1/4	\$2.39			MU 5/16X1/4	\$4.57	RB 1/4-3/16	\$2.95	RU 1/4-3/16	\$2.12		
5/16	ER 5/16-3/8	\$2.95	PE 5/16	\$2.93			MU 3/8X1/4	\$6.34	RB 5/16-1/4	\$2.95	RU 5/16-1/4	\$2.12	TU 5/16-1/4	\$2.95
3/8	ER 3/8-1/2	\$4.21	PE 3/8	\$5.24					RB 3/8-1/4	\$3.52	RU 3/8-1/4	\$2.47	TU 3/8-1/4	\$3.52
1/2			PE 1/2	\$5.24					RB 3/8-5/16	\$3.52	RU 3/8-5/16	\$2.47	TU 3/8-5/16	\$3.52
4 mm					MM 06-04-R1/8	\$5.20	MU 6-4	\$4.57	RB 1/2-3/8	\$4.22	RU 1/2-3/8	\$2.81	TU 1/2-3/8	\$4.21
6 mm	ER 4-6	\$2.95	PE 4	\$2.39	MM 08-04-R1/4	\$5.20	MU 8-4	\$4.57	RB 6-4	\$2.95	RU 6-4	\$1.83	TU 6-4	\$2.95
8 mm	ER 6-8	\$2.95	PE 6	\$2.93	MM 08-06-R3/8	\$6.72	MU 8-6	\$5.20	RB 8-6	\$2.95	RU 8-6	\$2.12	TU 8-6	\$2.95
10 mm	ER 8-10	\$3.52			MM 10-08-R3/8	\$7.10	MU 10-6	\$5.96	RB 10-8	\$3.52	RU 10-8	\$2.47	TU 10-8	\$3.52
12 mm	ER 10-12	\$4.21					MU 10-8	\$5.96	RB 12-10	\$4.22	RU 12-10	\$2.81	TU 12-10	\$4.21
Composite Fittings														
Model	Plug		Stem Coupler		Stem Reducer		Tube Reducer (Tube-Stem)		Model		Stack Elbow		Male Angle	
Tube OD	PG		SC		SR		TR		Tube OD	Pipe Size	SE		MA	
1/8	PG 1/8	\$0.64	SC 1/8	\$0.75					5/32	10-32	SE 5/32 10-32	\$4.44	MA 5/32 10-32	\$2.04
5/32	PG 5/32	\$0.64	SC 5/32	\$0.75	SR 1/8-5/32	\$1.01	TR 1/8-5/32	\$1.93	5/32	NPT1/8	SE 5/32 N1/8	\$4.44	MA 5/32 N1/8	\$2.04
3/16									1/4	10-32	SE 1/4 10-32		MA 1/4 10-32	
1/4	PG 1/4	\$0.64	SC 1/4	\$0.75	SR 5/32-1/4	\$1.01	TR 5/32-1/4	\$1.93	1/4	NPT1/8	SE 1/4 N1/8	\$3.94	MA 1/4 N1/8	\$2.04
5/16	PG 5/16	\$0.75	SC 5/16	\$1.01	SR 1/4-5/16	\$1.27	TR 1/4-5/16	\$2.28	1/4	NPT1/4	SE 1/4 N1/4	\$4.48	MA 1/4 N1/4	\$2.04
3/8	PG 3/8	\$0.75	SC 3/8	\$1.01	SR 1/4-3/8	\$1.27	TR 1/4-3/8	\$2.28	5/16	NPT1/4	SE 5/16 N1/4	\$4.10	MA 5/16 N1/4	\$1.87
1/2	PG 1/2	\$0.92	SC 1/2	\$1.08	SR 3/8-1/2	\$1.27	TR 3/8-1/2	\$3.08	5/16	NPT3/8	SE 5/16 N3/8	\$4.31	MA 5/16 N3/8	\$1.87
4 mm	PG 4	\$0.64	SC 4	\$0.75					3/8	NPT1/4	SE 3/8 N1/4	\$4.31	MA 3/8 N1/4	\$2.56
6 mm	PG 6	\$0.64	SC 6	\$0.75	SR 4-6	\$1.27	TR 4-6	\$1.93	3/8	NPT3/8	SE 3/8 N3/8	\$4.64	MA 3/8 N3/8	\$2.80
8 mm	PG 8	\$0.74	SC 8	\$1.01	SR 6-8	\$1.01	TR 6-8	\$2.28						
10 mm	PG10	\$0.75	SC10	\$1.01	SR 8-10	\$1.27	TR 8-10	\$2.28	1/2	NPT3/8	SE 1/2 N3/8	\$5.03	MA 1/2 N3/8	\$3.01
12 mm	PG 12	\$0.75	SC 12	\$1.01	SR 10-12	\$1.27	TR 10-12	\$3.08	1/2	NPT1/2	SE 1/2 N1/2	\$5.35	MA 1/2 N1/2	\$3.21

Miniature Composite Fittings													
Model		Male Connector		Compact Male Connector With Internal Hex		Male Elbow		Branch Tee		Run Tee		Female Connector	
Tube OD	Pipe Size	MCM		CCM		MEM		BTM		RTM		FCM	
1/8	10-32UNF	MCM 1/8 10-32	\$1.96	CCM 1/8 10-32	\$2.13	MEM 1/8 10-32	\$2.88	BTM 1/8 10-32	\$4.61	RTM 1/8 10-32	\$2.61	FCM 1/8 10-32	\$2.54
1/8	NPT1/8	MCM 1/8 N1/8	\$1.96	CCM 1/8 N1/8	\$2.13	MEM 1/8 N1/8	\$2.88	BTM 1/8 N1/8	\$4.61	RTM 1/8 N1/8	\$2.61	FCM 1/8 N1/8	\$2.54
5/32	10-32UNF	MCM 5/32 10-32	\$1.96	CCM 5/32 10-32	\$2.13	MEM 5/32 10-32	\$2.88	BTM 5/32 10-32	\$4.61	RTM 5/32 10-32	\$2.61	FCM5/32 10-32	\$2.54
5/32	NPT1/8	MCM 5/32 N1/8	\$1.96	CCM 5/32 N1/8	\$2.13	MEM 5/32 N1/8	\$2.88	BTM 5/32 N1/8	\$4.61	RTM 5/32 N1/8	\$2.61	FCM 5/32 N1/8	\$2.54
1/4	10-32UNF	MCM 1/4 10-32	\$1.96	CCM 1/4 10-32	\$2.13	MEM 1/4 10-32	\$2.88	BTM 1/4 10-32	\$4.61	RTM 1/4 10-32	\$3.46	FCM 1/4 10-32	\$2.54
1/4	NPT1/8	MCM 1/4 N1/8	\$1.96	CCM 1/4 N1/8	\$2.13	MEM 1/4 N1/8	\$2.88	BTM 1/4 N1/8	\$4.61	RTM 1/4 N1/8	\$3.46	FCM 1/4 N1/8	\$2.54

Miniature Composite Fittings									
Model		Cross Union		Elbow Union		Straight Union		Straight Union	
Tube OD		CUM		EUM		SUM		TUM	
1/8		CUM 1/8	\$4.61	EUM 1/8	\$2.65	SUM 1/8	\$2.65	TUM 1/8	\$3.69
5/32		CUM 5/32	\$4.61	EUM 5/32	\$2.65	SUM 5/32	\$2.65	TUM 5/32	\$3.69
1/4		CUM 1/4	\$4.61	EUM 1/4	\$2.65	SUM 1/4	\$2.65	TUM 1/4	\$3.69

Composite Fittings Specifications



A. Installation of Pipe Fittings:

1. Tighten fitting by hand, then turn it 2-3 turns with a wrench until it reaches the desire torque listed. If the fitting is not pre-coated with sealant, or is used and the sealant is not in good condition, apply Teflon sealant tape to the threads.

Recommendation of Torque for Tightening Fittings		
Fitting Thread Size	Torque, lb-ft	Torque, kgf/cm
10-32, M5 –M6	1.0 -1.5	14 –21
NPT1/8, R1/8	5 -6.5	70 -90
NPT1/4, R1/4	8.5 -10	120 -140
NPT3/8, R3/8	16 -17.5	220 -240
NPT1/2, R1/2	20 -21.5	280 -300

B. Installation of Tubing into Fitting:

1. Slowly push a clean and perpendicularly cut tubing into the fitting until it comes to a dead stop.
2. Pull the tubing back gently until the Grip Ring or Collet of the fitting grips onto the tubing and has a good seal.
3. Use Polyethylene, Polypropylene, Polyurethane or Nylon Tubing designed for instant fittings.

C. Removal of Tubing from Fitting:

1. Push in evenly on the two long oval sides of the Release Button.
2. Pull out the tube while depressing the Release Button.
3. To reuse the tubing, cut off the lodged portion of the previously used tubing in an even and perpendicular fashion.

D. Recommended Tubing Material, Size and Hardness Requirements:

Tubing Material	Specified Size	Hardness (Durometer)
Polyurethane	+/- 0.006" (+/-0.15 mm)	Shore A 85 or higher
Polyethylene	+/- 0.004" (+/-0.1 mm)	Shore D 44—D75
Polypropylene	+/- 0.004" (+/-0.1 mm)	Shore D 44—D75
Nylon	+/- 0.004" (+/-0.1 mm)	Shore D 44—D75
Pre-grooved Metal Tubing	+/- 0.004" (+/-0.1 mm)	

E. Specifications, Materials of Construction and Schematic of Typical Construction:

	Composite Fittings
Operating Pressure Range	0 - 180 PSI (0 - 1200 kpa)
Vacuum	0 - 29.5 in Hg (750 mm Hg)
Operating Temperature	32 - 140 °F (0 - 60 °C)
Recommended Tubing Material	Polyurethane, Nylon, Polyethylene, Polypropylene
Metal Body	Brass, Nickel Plated
Plastic Body	PBT (Polybutylene terephthalate)
Release Button	POM (Poly oxy methylene copolymer)
Grip Ring or Collet	300 series Stainless Steel
O-ring	NBR (Buna-N)
Thread Sealant	Teflon
Service	FOR AIR ONLY

SCHEMATIC OF TYPICAL COMPOSITE FITTING CONSTRUCTION

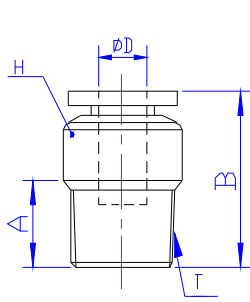

Compact Male Connector, CC

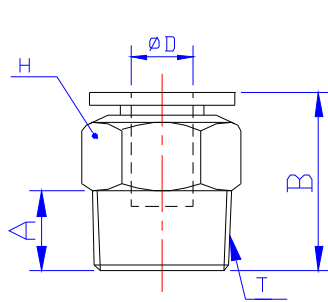

Male Connector, MC

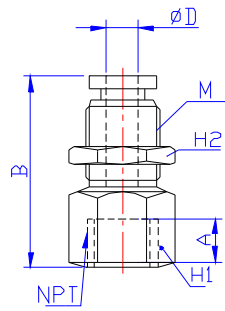

Bulkhead Connector, BC

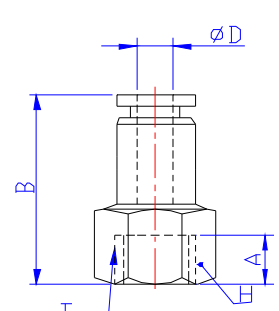

Female Connector, FC

ØD	T	Model	A	B	H	Model	A	B	H	Model	M	A	H1	H2	B	Model	A	B	H
5/32	10-32UNF	CC 5/32 10-32	3.8	20.3	Ø10.0	MC 5/32 10-32	3.8	20.3	11.1										
5/32	NPT1/8	CC 5/32 N1/8	7.5	19.8	Ø10.0	MC 5/32 N1/8	7.5	19.8	11.1	BC 5/32 N1/8	M12	7.5	14.3	14.3	23.8	FC 5/32 N1/8	7.5	23.8	14.3
5/32	NPT1/4	CC 5/32 N1/4				MC 5/32 N1/4	10.5	18.9	14.3							FC 5/32 N1/4	10.5	26.8	17.4
3/16	10-32UNF	CC 3/16 10-32				MC 3/16 10-32	3.8	20.9	11.1										
3/16	NPT1/8	CC 3/16 N1/8				MC 3/16 N1/8	7.5	20.6	11.1	BC 3/16 N1/8	M14	7.5	14.3	17.4	24.7	FC 3/16 N1/8	7.5	24.4	14.3
3/16	NPT1/4	CC 3/16 N1/4				MC 3/16 N1/4	10.5	23.7	14.3	BC 3/16 N1/4	M14	10.5	17.4	17.4	30.4	FC 3/16 N1/4	10.5	27.4	17.4
3/16	NPT3/8	CC 3/16 N3/8				MC 3/16 N3/8	11	21.2	17.4										
1/4	10-32UNF	CC 1/4 10-32	3.8	21.2	Ø12.0	MC 1/4 10-32	3.8	21.2	12.7										
1/4	NPT1/8	CC 1/4 N1/8	7.5	20.9	Ø12.0	MC 1/4 N1/8	7.5	20.9	12.7	BC 1/4 N1/8	M14	7.5	17.4	17.4	24.7	FC 1/4 N1/8	7.5	24.9	14.3
1/4	NPT1/4	CC 1/4 N1/4	10.5	23.7	Ø14.0	MC 1/4 N1/4	10.5	23.7	14.3	BC 1/4 N1/4	M14	10.5	17.4	17.4	30.4	FC 1/4 N1/4	10.5	27.9	17.4
1/4	NPT3/8	CC 1/4 N3/8				MC 1/4 N3/8	11	21.2	17.4										
5/16	NPT1/8	CC 5/16 N1/8	7.5	25.9	Ø14.0	MC 5/16 N1/8	7.5	25.9	14.3	BC 5/16 N1/8	M16	7.5	19	19	27.9	FC 5/16 N1/8	7.5	26.4	14.3
5/16	NPT1/4	CC 5/16 N1/4	10.5	25.9	Ø14.0	MC 5/16 N1/4	10.5	25.9	14.3	BC 5/16 N1/4	M16	10.5	19	19	35.9	FC 5/16 N1/4	10.5	29.4	17.4
5/16	NPT3/8	CC 5/16 N3/8	11	22.4	Ø17.0	MC 5/16 N3/8	11	22.4	17.4	BC 5/16 N3/8	M16	11	19	19	35.4	FC 5/16 N3/8	11	29.9	22.2
3/8	NPT1/8	CC 3/8 N1/8				MC 3/8 N1/8	7.5	28.2	17.4										
3/8	NPT1/4	CC 3/8 N1/4	10.5	30.5	Ø17.0	MC 3/8 N1/4	10.5	30.5	17.4	BC 3/8 N1/4	M20	10.5	22.2	22.2	31.9	FC 3/8 N1/4			
3/8	NPT3/8	CC 3/8 N3/8	11	27.5	Ø17.0	MC 3/8 N3/8	11	27.5	17.4	BC 3/8 N3/8	M20	11	22.2	22.2	34.7	FC 3/8 N3/8			
3/8	NPT1/2	CC 3/8 N1/2	14	25.8	Ø21.0	MC 3/8 N1/2	14	25.8	22.2										
1/2	NPT1/4	CC 1/2 N1/4	10.5	33.9	Ø21.0	MC 1/2 N1/4	10.5	33.9	22.2							FC 1/2 N1/4			
1/2	NPT3/8	CC 1/2 N3/8	11	30.4	Ø21.0	MC 1/2 N3/8	11	30.4	22.2	BC 1/2 N3/8	M22	11	25.4	25.4	35.4	FC 1/2 N3/8			
1/2	NPT1/2	CC 1/2 N1/2	14	33.4	Ø21.0	MC 1/2 N1/2	14	33.4	22.2	BC 1/2 N1/2	M22	14	25.4	25.4	41.4				

Tube OD	T	Model	B	H	Model	B	H	Model	H1	H2	B	Model	B	H
4	M5	CC 4 M5	22.8	10	MC 4 M5	22.8	10							
4	M6	CC 4 M6	24.3	10	MC 4 M6	24.3	10							
4	R1/8	CC 4 R1/8	20.9	10	MC 4 R1/8	20.9	10	BC 4 R1/8	14	14	27.5	FC 4 R1/8	27.5	12
4	R1/4	CC 4 R1/4	23.6	14	MC 4 R1/4	23.6	14	BC 4 R1/4	19	14	30.1	FC 4 R1/4	30.1	17
6	M5	CC 6 M5	24.1	12	MC 6 M5	24.1	12							
6	M6	CC 6 M6	25.8	12	MC 6 M6	25.8	12							
6	R1/8	CC 6 R1/8	22.3	12	MC 6 R1/8	22.3	12	BC 6 R1/8	17	17	28.8	FC 6 R1/8	28.8	14
6	R1/4	CC 6 R1/4	22.2	14	MC 6 R1/4	22.2	14	BC 6 R1/4	17	17	29.2	FC 6 R1/4	29.2	17
6	R3/8	CC 6 R3/8	24.1	17	MC 6 R3/8	24.1	17	BC 6 R3/8	19	17	31.2	FC 6 R3/8	31.2	19
6	R1/2	CC 6 R1/2	28.4	21	MC 6 R1/2	28.4	21							
8	R1/8	CC 8 R1/8	26.2	14	MC 8 R1/8	26.2	14	BC 8 R1/8	17	19	29.6	FC 8 R1/8	29.6	10
8	R1/4	CC 8 R1/4	25.7	14	MC 8 R1/4	25.7	14	BC 8 R1/4	17	19	30.5	FC 8 R1/4	30.5	17
8	R3/8	CC 8 R3/8	28.1	17	MC 8 R3/8	28.1	17	BC 8 R3/8	19	19	31.7	FC 8 R3/8	31.7	19
8	R1/2	CC 8 R1/2	28.0	21	MC 8 R1/2	28.0	21	BC 8 R1/2	24	19	36.8	FC 8 R1/2	36.8	24
10	R1/8	CC 10 R1/8	28.5	17	MC 10 R1/8	28.5	17	BC 10 R1/8	21	24	31.5	FC 10 R1/8	31.5	19
10	R1/4	CC 10 R1/4	30.0	17	MC 10 R1/4	30.0	17	BC 10 R1/4	21	24	32.7	FC 10 R1/4	32.7	19
10	R3/8	CC 10 R3/8	30.8	17	MC 10 R3/8	30.8	17	BC 10 R3/8	21	24	38.4	FC 10 R3/8	38.4	19
10	R1/2	CC 10 R1/2	29.6	21	MC 10 R1/2	29.6	21	BC 10 R1/2	24	24	38.4	FC 10 R1/2	38.4	24
12	R1/4	CC 12 R1/4	34.7	19	MC 12 R1/4	34.7	19	BC 12 R1/4	24	26	33.2	FC 12 R1/4	33.2	21
12	R3/8	CC 12 R3/8	30.5	19	MC 12 R3/8	30.5	19	BC 12 R3/8	24	26	37.0	FC 12 R3/8	37.0	21
12	R1/2	CC 12 R1/2	29.9	21	MC 12 R1/2	29.9	21	BC 12 R1/2	24	26	37.7	FC 12 R1/2	37.7	24

Units in mm

Composite Push-In Air Fittings Dimensions

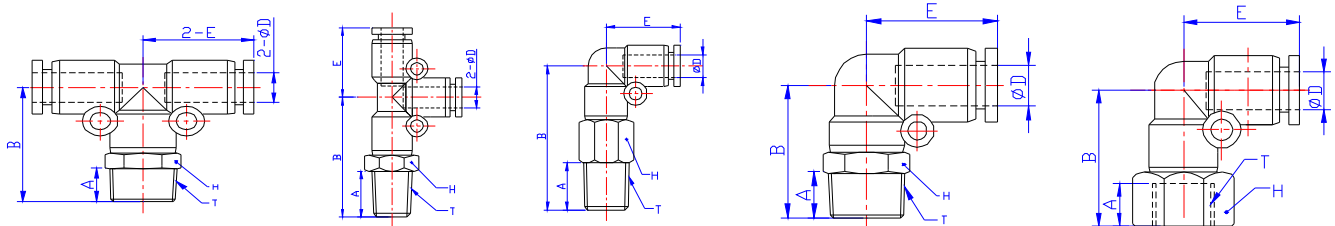

Branch Tee, BT

Run Tee, RT

Extended Elbow, EE

Male Elbow, ME

Female Elbow, FE

ΦD	T	A	H	Model	Model	B	E	Model	B	E	Model	B	E	Model	B	E	H
5/32	10-32UNF	3.8	11.1	BT 5/32 10-32	RT 5/32 10-32	23	18.5	EE5/32 10-32	33.5	17.5	ME 5/32 10-32	22	17.5	FE 5/32 10-32			
5/32	NPT1/8	7.5	11.1	BT 5/32 N1/8	RT 5/32 N1/8	25	18.5	EE 5/32 N1/8	36	17.5	ME 5/32 N1/8	24	17.5	FE 5/32 N1/8	23.5	17.5	14.3
5/32	NPT1/4	10.5	14.3	BT 5/32 N1/4	RT 5/32 N1/4	29	18.5				ME 5/32 N1/4	28	17.5	FE 5/32 N1/4			
3/16	10-32UNF	3.8	11.1	BT 3/16 10-32	RT 3/16 10-32	23	18.8				ME 3/16 10-32	22	17.8	FE 3/16 10-32			
3/16	NPT1/8	7.5	11.1	BT 3/16 N1/8	RT 3/16 N1/8	25.5	18.8	EE 3/16 N1/8	36	17.8	ME 3/16 N1/8	24.5	17.8	FE 3/16 N1/8	23.8	17.8	14.3
3/16	NPT1/4	10.5	14.3	BT 3/16 N1/4	RT 3/16 N1/4	29	18.8	EE 3/16 N1/4	39.5	17.8	ME 3/16 N1/4	28	17.8	FE 3/16 N1/4	26.5	17.8	17.4
3/16	NPT3/8	11	17.4	BT 3/16 N3/8	RT 3/16 N3/8	30	18.8	EE 3/16 N3/8	40.5	17.8	ME 3/16 N3/8	29	17.8				
1/4	10-32UNF	3.8	12.7	BT 1/4 10-32	RT 1/4 10-32	24.7	19.3				ME 1/4 10-32	24.4	19	FE 1/4 10-32			
1/4	NPT1/8	7.5	12.7	BT 1/4 N1/8	RT 1/4 N1/8	26	19.3	EE 1/4 N1/8	39.7	19	ME 1/4 N1/8	25.7	19	FE 1/4 N1/8	24.9	19	14.3
1/4	NPT1/4	10.5	14.3	BT 1/4 N1/4	RT 1/4 N1/4	29.5	19.3	EE 1/4 N1/4	43.2	19	ME 1/4 N1/4	29.2	19	FE 1/4 N1/4	27.9	19	17.4
1/4	NPT3/8	11	17.4	BT 1/4 N3/8	RT 1/4 N3/8	30.5	19.3	EE 1/4 N3/8	44.2	19	ME 1/4 N3/8	30.2	19	FE 1/4 N3/8			
5/16	NPT1/8	7.5	14.3	BT 5/16 N1/8	RT 5/16 N1/8	29.45	22.75	EE 5/16 N1/8	44.8	22.8	ME 5/16 N1/8	29.5	22.8	FE 5/16 N1/8	27.5	22.8	14.3
5/16	NPT1/4	10.5	14.3	BT 5/16 N1/4	RT 5/16 N1/4	32.45	22.75	EE 5/16 N1/4	47.8	22.8	ME 5/16 N1/4	32.5	22.8	FE 5/16 N1/4	31	22.8	17.4
5/16	NPT3/8	11	17.4	BT 5/16 N3/8	RT 5/16 N3/8	33.45	22.75	EE 5/16 N3/8	48.8	22.8	ME 5/16 N3/8	33.5	22.8	FE 5/16 N3/8	32	22.8	22.2
3/8	NPT1/8	7.5	17.4	BT 3/8 N1/8	RT 3/8 N1/8	35	27				ME 3/8 N1/8	34.3	26.3				
3/8	NPT1/4	10.5	17.4	BT 3/8 N1/4	RT 3/8 N1/4	38	27	EE 3/8 N1/4	56.3	26.3	ME 3/8 N1/4	37.3	26.3	FE 3/8 N1/4	35.3	26.3	17.4
3/8	NPT3/8	11	17.4	BT 3/8 N3/8	RT 3/8 N3/8	38.5	27	EE 3/8 N3/8	57.8	26.3	ME 3/8 N3/8	37.8	26.3	FE 3/8 N3/8	35.8	26.3	22.2
3/8	NPT1/2	14	22.2	BT 3/8 N1/2	RT 3/8 N1/2	42	27	EE 3/8 N1/2	61.3	26.3	ME 3/8 N1/2	41.3	26.3	FE 3/8 N1/2			
1/2	NPT1/4	10.5	22.2	BT 1/2 N1/4	RT 1/2 N1/4	39.5	29.6	EE 1/2 N1/4	62.5	29.6	ME 1/2 N1/4	39.5	29.6				
1/2	NPT3/8	11	22.2	BT 1/2 N3/8	RT 1/2 N3/8	40	29.6	EE 1/2 N3/8	63	29.6	ME 1/2 N3/8	40	29.6	FE 1/2-N3/8	37.5	29.6	22.2
1/2	NPT1/2	14	22.2	BT 1/2 N1/2	RT 1/2 N1/2	43	29.6	EE 1/2 N1/2	66	29.6	ME 1/2 N1/2	43	29.6	FE 1/2-N1/2	40.5	29.6	25.4

ΦD	Pipe Size	E	Model	Model	B	H	Model	B1	H	Model	B	H	Model	B2	H2
4	M5	18.1	BT 4 M5	RT 4 M5	23.0	10	EE 4 M5	36.1	10	ME 4 M5	23.0	10	FE 4 M5	20.9	10
4	M6	18.1	BT 4 M6	RT 4 M6	22.4	10	EE 4 M6	35.2	10	ME 4 M6	22.4	10	FE 4 M6	20.7	10
4	R1/8	18.1	BT 4 R1/8	RT 4 R1/8	26.1	10	EE 4 R1/8	36.8	10	ME 4 R1/8	26.1	10	FE 4 R1/8	22.3	12
4	R1/4	18.1	BT 4 R1/4	RT 4 R1/4	27.7	14	EE 4 R1/4	36.4	14	ME 4 R1/4	27.7	14	FE 4 R1/4	28.1	17
6	M5	21.1	BT 6 M5	RT 6 M5	25.8	12	EE 6 M5	39.0	12	ME 6 M5	25.8	12	FE 6 M5	23.0	12
6	M6	21.1	BT 6 M6	RT 6 M6	26.4	12	EE 6 M6	39.6	12	ME 6 M6	26.4	12	FE 6 M6	23.1	12
6	R1/8	21.1	BT 6 R1/8	RT 6 R1/8	28.1	12	EE 6 R1/8	38.8	12	ME 6 R1/8	28.1	12	FE 6 R1/8	26.0	14
6	R1/4	21.1	BT 6 R1/4	RT 6 R1/4	29.2	14	EE 6 R1/4	45.0	14	ME 6 R1/4	29.2	14	FE 6 R1/4	28.5	17
6	R3/8	21.1	BT 6 R3/8	RT 6 R3/8	31.7	17	EE 6 R3/8	44.9	17	ME 6 R3/8	31.7	17	FE 6 R3/8	33.4	19
6	R1/2	21.1	BT 6 R1/2	RT 6 R1/2	34.9	21	EE 6 R1/2	48.1	21	ME 6 R1/2	34.9	21			
8	R1/8	23.1	BT 8 R1/8	RT 8 R1/8	30.1	14	EE 8 R1/8	42.2	14	ME 8 R1/8	30.1	14			
8	R1/4	23.1	BT 8 R1/4	RT 8 R1/4	30.8	14	EE 8 R1/4	46.7	14	ME 8 R1/4	30.8	14	FE 8 R1/8	28.6	14
8	R3/8	23.1	BT 8 R3/8	RT 8 R3/8	33.6	17	EE 8 R3/8	46.5	17	ME 8 R3/8	33.6	17	FE 8 R1/4	30.0	17
8	R1/2	23.1	BT 8 R1/2	RT 8 R1/2	35.2	21	EE 8 R1/2	52.7	21	ME 8 R1/2	35.2	21	FE 10 R1/8	30.7	17
10	R1/8	27.9	BT 10 R1/8	RT 10 R1/8	32.6	17	EE 10 R1/8	53.1	17	ME 10 R1/8	32.6	17			
10	R1/4	27.9	BT 10 R1/4	RT 10 R1/4	35.1	17	EE 10 R1/4	56.3	17	ME 10 R1/4	35.1	17	FE 10 R1/4	31.1	17
10	R3/8	27.9	BT 10 R3/8	RT 10 R3/8	36.6	17	EE 10 R3/8	57.0	17	ME 10 R3/8	36.6	17	FE 10 R3/8	34.4	19
10	R1/2	27.9	BT 10 R1/2	RT 10 R1/2	38.6	21	EE 10 R1/2		21	ME 10 R1/2	38.6	21	FE 10 R1/2	37.8	24
12	R1/4	28.3	BT 12 R1/4	RT 12 R1/4	35.2	19	EE 12 R1/4	62.6	19	ME 12 R1/4	35.2	19	FE 12 R1/4	36.4	19
12	R3/8	28.3	BT 12 R3/8	RT 12 R3/8	37.5	19	EE 12 R3/8	62.9	19	ME 12 R3/8	37.5	19	FE 12 R3/8	39.0	19
12	R1/2	28.3	BT 12 R1/2	RT 12 R1/2	39.8	21	EE 12 R1/2		21	ME 12 R1/2	39.8	21	FE 12 R1/2	42.8	24

Units in mm

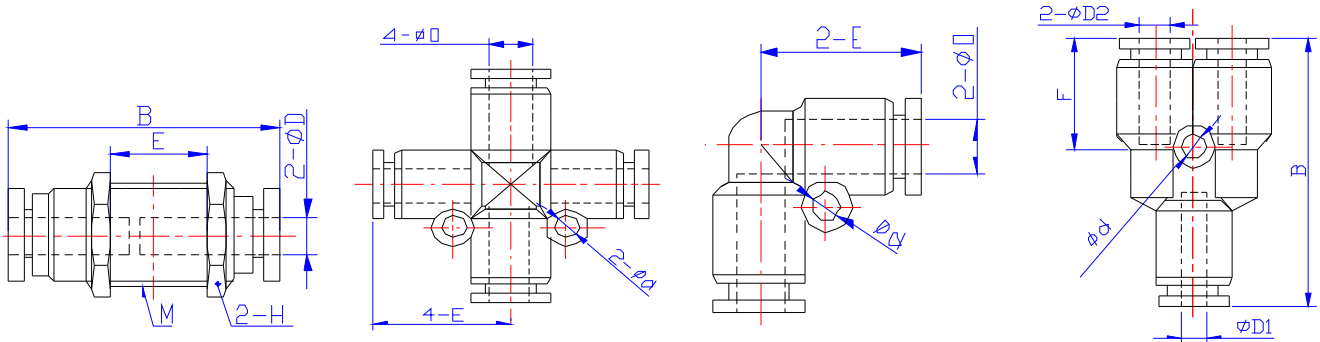

Bulkhead Union, BU

Cross Union, CU

Elbow Union, EU

Reduced Branch, RB

φD	Model	B	E	H	M	Model	Ød	E	Model	E	Ød	Model	ØD1	ØD2	Ød	B	F	
5/32	BU 5/32	30.1	9.7	14.3	M12	CU 5/32	3.2	17.5	EU 5/32	17.5	3.2	RB 3/16-5/32	3/16	5/32	3.2	35.8	14.0	
3/16	BU 3/16	31.8	7.5	17.4	M14	CU 3/16	3.2	17.8	EU 3/16	17.8	3.2	RB 1/4-5/32	1/4	5/32	3.2	36.8	14.5	
1/4	BU 1/4	31.8	7.5	17.4	M14	CU 1/4	3.2	19.3	EU 1/4	19	3.2	RB 1/4-3/16	1/4	3/16	3.2	37.1	14.8	
5/16	BU 5/16	35.3	6.8	19.0	M16	CU 5/16	3.2	22.75	EU 5/16	22.8	3.2	RB 5/16-1/4	5/16	1/4	3.2	39.9	17.7	
3/8	BU 3/8	36.4	8.9	22.2	M20	CU 3/8	4.2	27	EU 3/8	26.3	4.2	RB 3/8-1/4						
1/2	BU 1/2	45.3	12.8	25.4	M22	CU 1/2	4.3	29.6	EU 1/2	29.6	4.3	RB 3/8-5/16	3/8	5/16	4.2	47.9	20.3	
												RB 1/2-3/8	1/2	3/8	4.2	51.6	20.0	
4	BU 4	35.2	13.4	14.0	12.0	CU 4	2.0	18.2	EU 4	18.2	3.0							
6	BU 6	35.4	14.3	17.0	14.0	CU 6	3.0	21.0	EU 6	21.0	3.0	RB 6-4			10.5	2.0	36.7	14.5
8	BU 8	41.1	16.2	19.0	16.0	CU 8	3.0	23.0	EU 8	23.0	3.0	RB 8-6			13.2	3.0	42.4	17.2
10	BU 10	44.7	16.6	24.0	20.0	CU 10	3.0	27.4	EU 10	27.4	3.0	RB 10-8			14.8	4.0	50.2	20.1
12	BU 12	45.3	16.6	26.0	22.0	CU 12	2.5	27.4	EU 12	27.4	3.0	RB 12-10			18.4	4.0	54.6	22.4

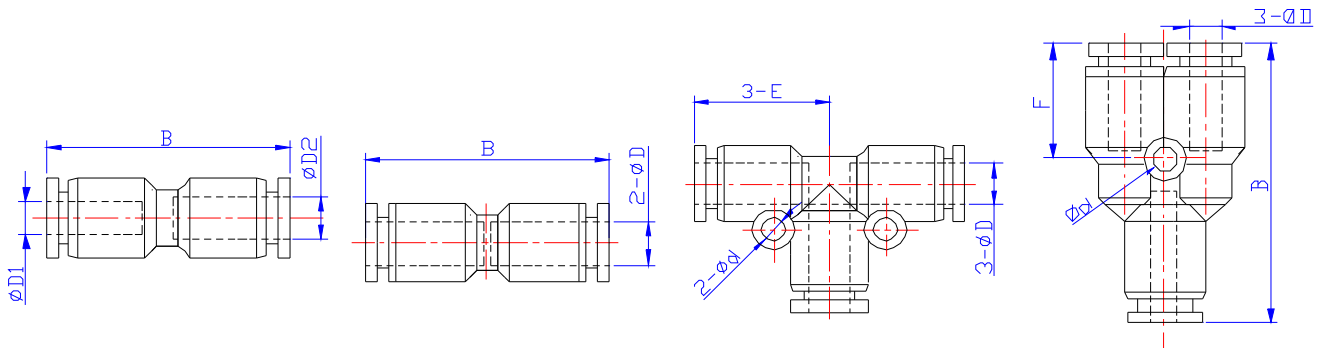

Reduced Union, RU

Straight Union, SU

Tee Union, TU

Y Union, YU

Part No.	ØD1	ØD2	B	Part No.	ØD	B	Part No.	ØD	Ød	E	Part No.	ØD	Ød	B	F
RU 3/16-5/32	3/16	5/32	33.3	SU 5/32	5/32	33	TU 5/32	5/32	3.2	18.5	YU 5/32	5/32	3.2	35.5	14.0
RU 1/4-5/32	1/4	5/32	34.9	SU 3/16	3/16	33.6	TU 3/16	3/16	3.2	18.8	YU 3/16	3/16	3.2	36.1	14.3
RU 1/4-3/16	1/4	3/16	35.2	SU 1/4	1/4	35.2	TU 1/4	1/4	3.2	19.3	YU 1/4	1/4	3.2	37.1	14.8
RU 5/16-1/4	5/16	1/4	38.6	SU 5/16	5/16	39.1	TU 5/16	5/16	3.2	22.75	YU 5/16	5/16	3.2	40.4	18.2
RU 3/8-1/4				SU 3/8	3/8	45.2	TU 3/8	3/8	4.2	27	YU 3/8	3/8	4.2	47.1	19.5
RU 3/8-5/16	3/8	5/16	47.3	SU 1/2	1/2	49.2	TU 1/2	1/2	4.3	29.6	YU 1/2	1/2	4.2	53.2	21.6
RU 1/2-3/8	1/2	3/8	48.9												
RU 6-4	4	6	33.9	SU 4		30.8	TU 4		3	18.2	YU 4		3	33.5	14.9
RU 8-6	6	8	38.7	SU 6		37.6	TU 6		3	21	YU 6		3	37	15.8
RU 10-8	8	10	42.5	SU 8		39.5	TU 8		3	23	YU 8		3	38.4	16
RU 12-10	10	12	47.4	SU 10		47.1	TU 10		3	27.4	YU 10		4	52.1	19.1
				SU 12		50.3	TU 12		3	27.4	YU 12		4	54.8	21.6

Units in mm

Composite Push-In Air Fittings Dimensions

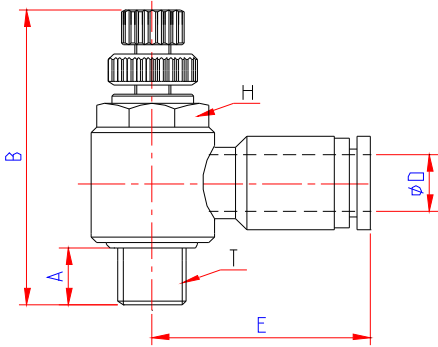

CV = Air Control Valve (meter-out)
CI = Air Control Valve (meter-in)

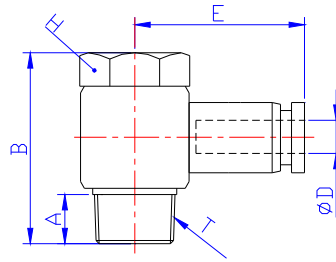

Universal Elbow, UE

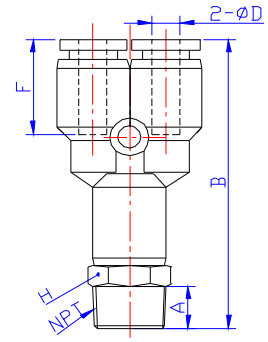

Y Connector, YC

ØD	T	A	H	Model (CV/CI)	B	E	Model	B	E	Part No.	A	B	F	H
5/32	10-32	3.8	8	CV 5/32 10-32	29.3	20	UE 5/32 10-32	17	20	YC 5/32 10-32	3.8	40	14	11.1
5/32	NPT1/8	7.5	11.1	CV 5/32 N1/8	40.1	22.6	UE 5/32 N1/8	23.5	22.3	YC 5/32 N1/8	7.5	42	14	11.1
5/32	NPT1/4									YC 5/32 N1/4	10.5	46	14	14.3
3/16	10-32	3.8	8				UE 3/16 10-32	17	20.3	YC 3/16 10-32	3.8	40.3	14.3	11.1
3/16	NPT1/8	7.5	11.1				UE 3/16 N1/8	23.5	22.6	YC 3/16 N1/8	7.5	42.8	14.3	11.1
3/16	NPT1/4	10.5	14.3				UE 3/16 N1/4	27.3	24.3	YC 3/16 N1/4	10.5	46.3	14.3	14.3
3/16	NPT3/8									YC 3/16 N3/8	11	47.3	14.3	17.4
1/4	10-32	3.8	8	CV 1/4 10-32	29.3	22				YC 1/4 10-32	3.8	42.5	14.8	12.7
1/4	NPT1/8	7.5	11.1	CV 1/4 N1/8	40.1	23.1	UE 1/4 N1/8	23.5	23.1	YC 1/4 N1/8	7.5	43.8	14.8	12.7
1/4	NPT1/4	10.5	14.3	CV 1/4 N1/4	47.2	25.1	UE 1/4 N1/4	27.3	25.1	YC 1/4 N1/4	10.5	47.3	14.8	14.3
1/4	NPT3/8	11	19	CV 1/4 N3/8	53.9	26.8				YC 1/4 N3/8	11	48.3	14.8	17.4
5/16	NPT1/8	7.5	11.1	CV 5/16 N1/8	40.1	25.6	UE 5/16 N1/8	23.5	25.6	YC 5/16 N1/8	7.5	47.1	18.2	14.3
5/16	NPT1/4	10.5	14.3	CV 5/16 N1/4	47.2	28.6	UE 5/16 N1/4	27.3	28.6	YC 5/16 N1/4	10.5	50.1	18.2	14.3
5/16	NPT3/8	11	19	CV 5/16 N3/8	53.9	29.6	UE 5/16 N3/8	32.4	29.6	YC 5/16 N3/8	11	51.1	18.2	17.4
3/8	NPT1/8									YC 3/8 N1/8	7.5	55.1	19.5	17.4
3/8	NPT1/4	10.5	14.3	CV 3/8 N1/4	47.2	31	UE 3/8 N1/4	27.3	31	YC 3/8 N1/4	10.5	58.1	19.5	17.4
3/8	NPT3/8	11	19	CV 3/8 N3/8	53.9	31.6	UE 3/8 N3/8	32.4	31.6	YC 3/8 N3/8	11	58.6	19.5	17.4
3/8	NPT1/2	14	25.4	CV 3/8 N1/2	58.4	34.6				YC 3/8 N1/2	14	62.1	19.5	22.2
1/2	NPT1/4									YC 1/2 N1/4	10.5	63.1	21.6	22.2
1/2	NPT3/8	11	19	CV 1/2 N3/8	53.9	35.6	UE 1/2 N3/8	32.4	35.6	YC 1/2 N3/8	11	63.6	21.6	22.2
1/2	NPT1/2	14	25.4	CV 1/2 N1/2	58.4	36.6	UE 1/2 N1/2	39.1	36.6	YC 1/2 N1/2	14	66.6	21.6	22.2

ØD	T		H	Model (CV/CI)		E	Model			Model		B	F	H
4	M5		8	CV 4 M5		20.7	UE 4 M5			YC 4 M5		38.8	13.8	10
4	M6		8	CV 4 M6		20.6	UE 4 M6			YC 4 M6		38.5	13.9	10
4	R1/8		10	CV 4 R1/8		22.2	UE 4 R1/8			YC 4 R1/8		40.1	14.3	10
4	R1/4		14	CV 4 R1/4		27.3	UE 4 R1/4			YC 4 R1/4		42.5	13.9	14
6	M5		8	CV 6 M5		23.1	UE 6 M5			YC 6 M5		41.6	15.5	12
6	M6		8	CV 6 M6		23.8	UE 6 M6			YC 6 M6		42.8	15.3	12
6	R1/8		10	CV 6 R1/8		23.6	UE 6 R1/8			YC 6 R1/8		44.3	15.5	12
6	R1/4		14	CV 6 R1/4		25.5	UE 6 R1/4			YC 6 R1/4		44.8	15.3	14
6	R3/8		19	CV 6 R3/8		27.8	UE 6 R3/8			YC 6 R3/8		47.6	15.4	17
6	R1/2									YC 6 R1/2		50.6	15.1	21
8	R1/8		10	CV 8 R1/8		26.5	UE 8 R1/8			YC 8 R1/8		45.4	16.9	14
8	R1/4		14	CV 8 R1/4		27.8	UE 8 R1/4			YC 8 R1/4		46.4	16.9	14
8	R3/8		19	CV 8 R3/8		31.4	UE 8 R3/8			YC 8 R3/8		48.3	15.7	17
8	R1/2		24	CV 8 R1/2		30.3	UE 8 R1/2			YC 8 R1/2		50.5	17.1	21
10	R1/8									YC 10 R1/8		57.0	21.0	17
10	R1/4		14	CV 10 R1/4		34.0	UE 10 R1/4			YC 10 R1/4		59.3	21.2	17
10	R3/8		19	CV 10 R3/8		33.4	UE 10 R3/8			YC 10 R3/8		60.5	20.0	17
10	R1/2		24	CV 10 R1/2		35.2	UE 10 R1/2			YC 10 R1/2		62.9	21.4	21
12	R1/4		14	CV 12 R1/4		34.2	UE 12 R1/4			YC 12 R1/4		61.4	21.9	19
12	R3/8		19	CV 12 R3/8		34.2	UE 12 R3/8			YC 12 R3/8		63.4	21.8	19
12	R1/2		24	CV 12 R1/2		37.2	UE 12 R1/2			YC 12 R1/2		65.5	21.8	21

Units in mm

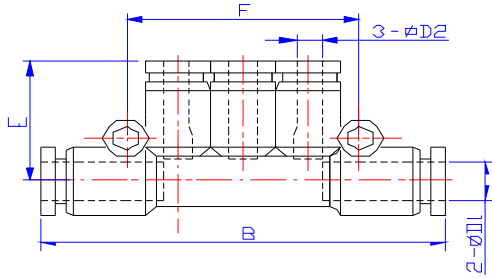

Manifold Union, MU

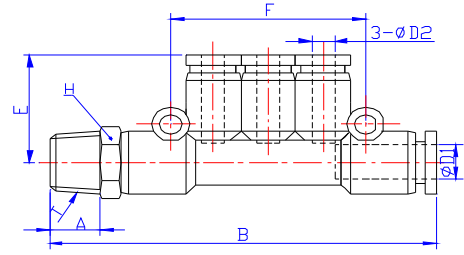

Male Manifold, MM

Part No.	ØD	B	E	F	Model	ØD1	ØD2	B	E	F	Part No.	ØD1	ØD2	T	A	B	E	F	H
MU 5/32	5/32	57	19	36	MU 3/16-5/32	3/16	5/32	57.6	19	36	MM 3/16-5/32-N1/8	3/16	5/32	NPT 1/8	7.5	64.3	19	36	11.1
MU 3/16	3/16	57.6	19.3	36	MU 1/4-5/32	1/4	5/32	57.6	19	36	MM 1/4-5/32-N1/8	1/4	5/32	NPT 1/8	7.5	64.3	19	36	12.7
MU 1/4	1/4	61.6	20.3	42	MU 5/16-5/32	5/16	5/32	62.6	20	42	MM 5/16-5/32-N1/4	5/16	5/32	NPT 1/4	10.5	72.3	20	42	14.3
MU 5/16	5/16	81.6	24.3	48	MU 5/16-3/16	5/16	3/16	62.6	20.3	42	MM 5/16-3/16-N1/4	5/16	3/16	NPT 1/4	10.5	72.3	20.3	42	14.3
					MU 5/16-1/4	5/16	1/4	62.6	20.3	42	MM 5/16-1/4-N1/4	5/16	1/4	NPT 1/4	10.5	72.3	20.3	42	14.3
					MU 3/8-1/4	3/8	1/4	80	23.8	48	MM 3/8-5/16-N3/8	3/8	5/16	NPT 3/8	11	91.5	24.3	48	17.4
					MU 3/8-5/16	3/8	5/16	80	24.3	48									
					MU-6-04	6.0	4.0	61.3		40.4	MM06-04-R1/8	6.0	4.0	R1/8		68.5		40.4	12
					MU-8-04	8.0	4.0	61.7		40.9	MM08-6-R1/4	8.0	6.0	R1/4		69.9		40.9	14
					MU-8-06	8.0	6.0	62.7		40.9	MM10-8-R3/8	10.0	8.0	R3/8		91.6		47.9	17
					MU-10-06	10.0	6.0	82.9		47.1									
					MU-10-08	10.0	8.0	83.0		47.9									

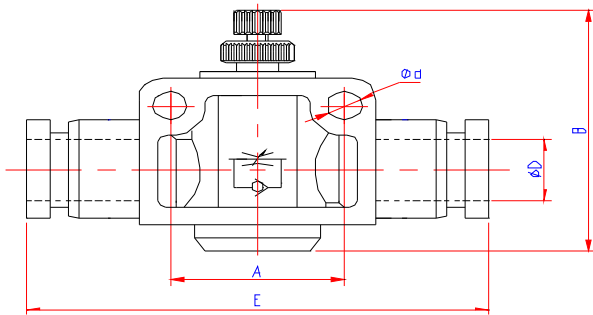

Air Flow Control Valve, FV

Part No.	ØD	Ød	A	B	E
FV 5/32	5/32	3.2	14	28.8	39.5
FV 3/16	3/16	3.2	14	28.8	40.1
FV 1/4	1/4	4.3	20	42.6	47.6
FV 5/16	5/16	4.3	22	44.3	52.6
FV 3/8	3/8	4.3	26	53.4	60.5
FV 1/2	1/2	4.3	32	55.6	74.2
FV-4	4	3.0			39.9
FV-6	6	4.0			49.6
FV-8	8	4.0			55.2
FV-10	10	4.0			64.9
FV-12	12	4.0			75.7

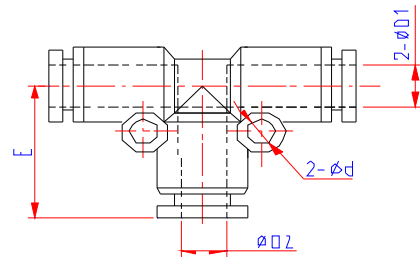

Tee Union Reducer, TU

TU				
Model	ΦD1	ΦD2	Φd	E
TU 1/4-5/32	1/4	5/32	3.2	19.0
TU 5/16-1/4	5/16	1/4	3.2	22.3
TU 3/8-5/16	3/8	5/16	3.2	27.8
TU 1/2-3/8	1/2	3/8	4.2	29.3

Units in mm

Composite Push-In Air Fittings Dimensions

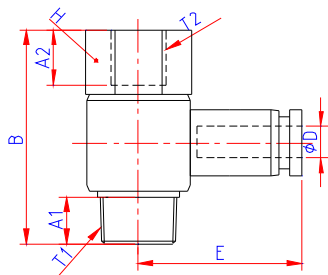

Stack Elbow, SE

SE								
ØD	T1	T2	Model	A1	A2	H	B	E
5/32	10-32UNF	10-32UNF	SE 5/32 10-32	3.8	5.5	11.1	19.5	20
	NPT1/8	NPT1/8	SE 5/32 N1/8	7.5	7.5	14.3	30	22.3
3/16	10-32UNF	10-32UNF	SE 3/16 10-32	3.8	5.5	11.1	19.5	20.3
	NPT1/8	NPT1/8	SE 3/16 N1/8	7.5	7.5	14.3	30	22.6
1/4	NPT1/4	NPT1/4	SE 3/16 N1/4	10.5	10.5	17.4	35.8	24.3
	NPT1/8	NPT1/8	SE 1/4 N1/8	7.5	7.5	14.3	30	23.1
5/16	NPT1/4	NPT1/4	SE 1/4 N1/4	10.5	10.5	17.4	35.8	25.1
	NPT1/8	NPT1/8	SE 5/16 N1/8	7.5	7.5	14.3	30	25.6
3/8	NPT1/4	NPT1/4	SE 5/16 N1/4	10.5	10.5	17.4	35.8	28.6
	NPT3/8	NPT3/8	SE 5/16 N3/8	11	11	22.2	40.9	29.6
1/2	NPT1/4	NPT1/4	SE 3/8 N1/4	10.5	10.5	17.4	35.8	31
	NPT3/8	NPT3/8	SE 3/8 N3/8	11	11	22.2	40.9	31.6
1/2	NPT3/8	NPT3/8	SE 1/2 N3/8	11	11	22.2	40.9	35.6
	NPT1/2	NPT1/2	SE 1/2 N1/2	14	14	25.4	49	36.6

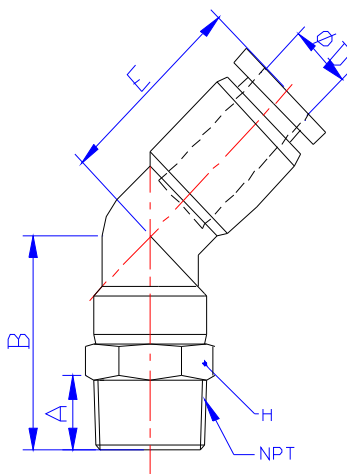

Male Angle, MA

MA						
ØD	NPT	Model	A	B	E	H
5/32	10-32UNF	MA 5/32 10-32	3.8	20.7	16.2	11.1
	NPT1/8	MA 5/32 N1/8	7.5	22.7		14.3
	NPT1/4	MA 5/32 N1/4	10.5	26.7		17.4
3/16	10-32UNF	MA 3/16 10-32	3.8	20.7	16.5	11.1
	NPT1/8	MA 3/16 N1/8	7.5	23.2		14.3
	NPT3/8	MA 3/16 N3/8	11	27.7		17.4
1/4	10-32UNF	MA 1/4 10-32	3.8	23.1	17.7	12.7
	NPT1/8	MA 1/4 N1/8	7.5	24.4		14.3
	NPT1/4	MA 1/4 N1/4	10.5	27.9		17.4
5/16	NPT3/8	MA 1/4 N3/8	11	28.9	20.9	14.3
	NPT1/8	MA 5/16 N1/8	7.5	27.6		17.4
	NPT3/8	MA 5/16 N3/8	11	31.6		17.4
3/8	NPT1/8	MA 3/8 N1/8	7.5	30.2	22.2	17.4
	NPT1/4	MA 3/8 N1/4	10.5	33.2		17.4
	NPT3/8	MA 3/8 N3/8	11	33.7		17.4
	NPT1/2	MA 3/8 N1/2	14	37.2		22.2
1/2	NPT1/4	MA 1/2 N1/4	10.5	36.2	26.3	22.2
	NPT3/8	MA 1/2 N3/8	11	36.7		22.2
	NPT1/2	MA 1/2 N1/2	14	39.7		22.2

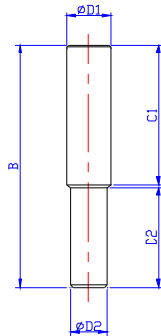

Stem Reducer, SR

SR					
Model	ØD1	ØD2	C1	C2	B
SR 3/16-5/32	3/16	5/32	18	17	36
SR 1/4-5/32	1/4	5/32	18	17	36
SR 1/4-3/16	1/4	3/16	18	17	36
SR 5/16-1/4	3/16	1/4	20	18	39
SR 3/8-5/16	3/8	5/16	25	20	46
SR 1/2-3/8	1/2	3/8	27	26	54

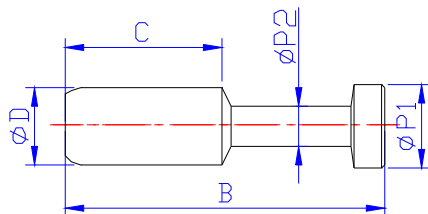

Plug, PG

PG					
Model	ØD	B	ØP1	ØP2	C
PG 5/32	5/32	28	5	3	15
PG 3/16	3/16	28	5	3	15
PG 1/4	1/4	33	7	3	17
PG 5/16	5/16	37	9	4	18
PG 3/8	3/8	42	11	5	20.5
PG 1/2	1/2	44	13	6	23

Units in mm

Units in mm

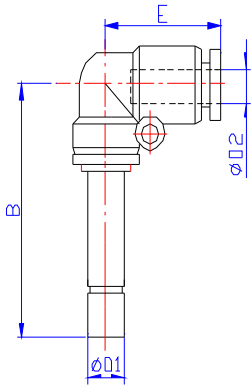

Elbow Reducer, ER

ER				
Model	ØD1	ØD2	B	E
ER 1/8-5/32	5/32	1/8	33	17.5
ER 5/32-1/4	1/4	5/32	35	17.5
ER 1/4-3/8	3/8	1/4	42.5	22.8
ER 1/4-5/16	5/16	1/4	39.2	19
ER 5/16-3/8	3/8	5/16	42.5	22.8
ER 3/8-1/2	1/2	3/8	52.8	26.3

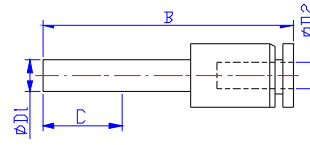

TR (Tube Reducer)				
Model	ØD1	ØD2	B	C
TR 5/32-1/4	1/4	5/32	39.5	16
TR 5/32-5/16	5/16	5/32	41.5	18.6
TR 1/4-5/16	5/16	1/4	41.8	18.6
TR 1/4-3/8	3/8	1/4	46.5	20
TR 5/16-3/8	3/8	5/16	46.5	20
TR 1/4-1/2	1/2	1/4	51.8	23.5
TR 5/16-1/2	1/2	5/16	52.3	23.5
TR 3/8-1/2	1/2	3/8	51.5	23.5

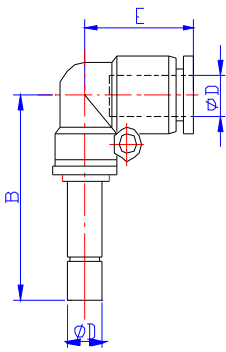

Plug-In Elbow, PE

PE			
Model	ØD	B	E
PE 5/32	5/32	33	17.5
PE 3/16	3/16	33	17.8
PE 1/4	1/4	36.2	19
PE 5/16	5/16	42.5	22.8
PE 3/8	3/8	50.8	26.3
PE 1/2	1/2	54.5	29.6

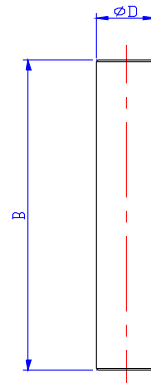

Stem Coupling, SC

SC		
Model	ØD	B
SC 5/32	5/32	35
SC 3/16	3/16	35
SC 1/4	1/4	37
SC 5/16	5/16	41
SC 3/8	3/8	51
SC 1/2	1/2	54

STC FLOW CONTROL VALVES AIR FLOW CHARACTERISTICS

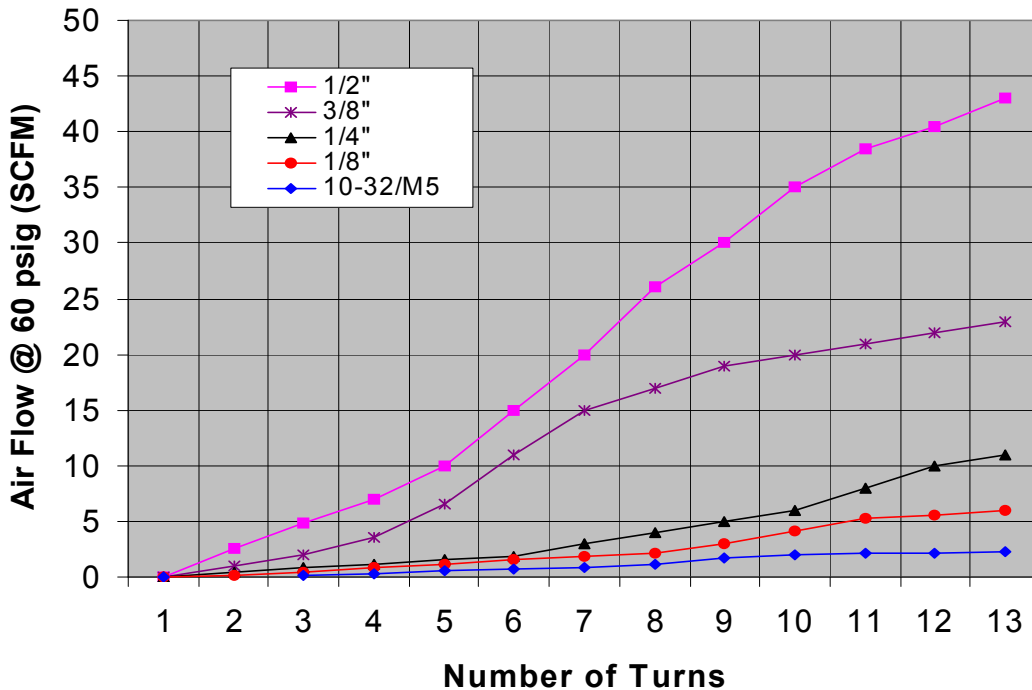

Special Features:

- Complete rotation of the valve body around the bolt allows for optimum positioning of tubing
- Compact in size provide space saving installations
- Special adjustment needle design allows large adjustment ranges with high precision
- Adjustment needles and banjo bodies are retained, preventing accidental loss of needle or lock nut

Stainless Steel & Nickel Plated Push-In Fittings and Compression Fittings



Contents

STC Stainless Steel & Nickel-Plated Brass Fittings Numbering System.....	B2
STC Stainless Steel Push-In Fittings List Price.....	B3
STC Nickel-Plated Brass Push-In Fittings List Price.....	B4
Stainless Steel & Nickel-Plated Brass Push-In Fittings Specifications.....	B5
STC Stainless Steel & Nickel-Plated Brass Fittings Dimensions.....	B6-7
STC Compression Fittings Numbering System & Specifications.....	B8
STC Compression Fittings Specifications.....	B8
STC Compression Fittings List Price.....	B9-10

STC Stainless Steel & Nickel-Plated Brass Fittings Numbering System





Ordering Part No. = (eg. BCS 1/8 10-32)	BC	S	1/8	10-32	[]
	↓	↓	↓	↓	↓
Fitting Name	Model	Material/Type	Tube OD	Thread Size /Stem/Tube	Stainless Steel Fitting Options
BULKHEAD CONNECTOR	BC	S = 316 Stainless Steel	(inch) 1/8 5/32 3/16 1/4 5/16 3/8 1/2 (mm) 4 6 8 10 12 14 16	THREAD SIZE: N= NPT N1/8 N1/4 N3/8 N1/2 R=PT (British Standard Pipe Taper Thread) R1/8 R1/4 R3/8 R1/2 G=PP (British Standard Parallel Pipe Thread) G1/8 G1/4 G3/8 G1/2 U=Universal Threads (fits NPT, R & G) U1/8 U1/4 U3/8 U1/2 Machine Thread 10-32 M5 M6 STEM SIZE: 1/8-1/2" 4-12 mm	Tube Gripping/Releasing Mechanism: Blank = Collet Style with Stainless Steel Release Button W = Gripper Style with Stainless Steel Release Button
BRANCH TEE	BT				
BULKHEAD UNION	BU				
CROSS UNION	CU				
ELBOW UNION	EU				
FEMALE CONNECTOR	FC				
FEMALE ELBOW	FE				
MALE CONNECTOR	MC				
MALE ELBOW	ME				
PLUG	PG				
REDUCED UNION	RU				
RUN TEE	RT				
STEM COUPLING	SC				
STEM REDUCER	SR				
STRAIGHT UNION	SU				
TEE UNION	TU				
TUBE ADAPTOR	TA				
TUBE REDUCER	TR				

316 Stainless Steel Push-In Fittings



Stainless Steel Fittings	Bulkhead Union		Elbow Union		Reduced Union		Straight Union		Tube Reducer		Tee Union		Cartridge Fitting		Stem Coupler	
	Part No.	Unit Price	Part No.	Unit Price	Part No.	Unit Price	Part No.	Unit Price	Part No.	Unit Price	Part No.	Unit Price	Part No.	Unit Price	Part No.	Unit Price
1/8"	BUS 1/8	\$14.53	EUS 1/8	\$17.42	RUS 5/32-1/8	\$14.53	SUS 1/8	\$10.95	TRS 1/8-5/32	\$10.95	TUS 1/8	\$21.37	CFS 1/8	\$5.38	SCS 1/8	\$2.88
5/32"	BUS 5/32	\$14.53	EUS 5/32	\$17.41	RUS 1/4-5/32	\$17.11	SUS 5/32	\$10.95	TRS 5/32-1/4	\$10.95	TUS 5/32	\$21.37	CFS 5/32	\$5.38	SCS 5/32	\$2.88
1/4"	BUS 1/4	\$17.11	EUS 1/4	\$20.00	RUS 5/16-1/4	\$21.90	SUS 1/4	\$10.95	TRS 1/4-3/8	\$10.95	TUS 1/4	\$24.57	CFS 1/4	\$5.68	SCS 1/4	\$2.88
5/16"	BUS 5/16	\$21.90	EUS 5/16	\$20.91	RUS 3/8-5/16	\$23.27	SUS 5/16	\$11.93	TRS 5/16-3/8	\$11.93	TUS 5/16	\$27.74	CFS 5/16	\$7.46	SCS 5/16	\$3.23
3/8"	BUS 3/8	\$23.27	EUS 3/8	\$22.81	RUS 1/2-3/8	\$30.03	SUS 3/8	\$12.93	TRS 3/8-1/2	\$12.93	TUS 3/8	\$30.88	CFS 3/8	\$8.38	SCS 3/8	\$3.46
1/2"	BUS 1/2	\$30.03	EUS 1/2	\$26.24			SUS 1/2	\$15.66			TUS 1/2	\$36.13	CFS 1/2	\$9.72	SCS 1/2	\$4.03
4 mm	BUS 4	\$14.53	EUS 4	\$17.41	RUS 6-4	\$20.53	SUS 4	\$9.81	TRS 4-6	\$9.81	TUS 4	\$21.37			SCS 4	\$2.88
6 mm	BUS 6	\$20.53	EUS 6	\$20.00	RUS 8-6	\$21.87	SUS 6	\$10.95	TRS 6-8	\$10.95	TUS 6	\$24.57			SCS 6	\$2.88
8 mm	BUS 8	\$21.90	EUS 8	\$20.91	RUS 10-8	\$23.27	SUS 8	\$11.93	TRS 8-10	\$11.93	TUS 8	\$27.74			SCS 8	\$2.88
10 mm	BUS 10	\$23.27	EUS 10	\$22.81	RUS 12-10	\$30.03	SUS 10	\$12.93	TRS 10-12	\$12.93	TUS 10	\$30.88			SCS 10	\$3.46
12 mm	BUS 12	\$30.03	EUS 12	\$26.24			SUS 12	\$15.66			TUS 12	\$36.13			SCS 12	\$4.03

Stainless Steel Fittings	Female Connector		Branch Tee (Swivel)		Female Connector		Male Connector		Male Elbow (Swivel)		Run Tee (Swivel)		Tube Adaptor		
	Part No.	Unit Price	Part No.	Unit Price	Part No.	Unit Price	Part No.	Unit Price	Part No.	Unit Price	Part No.	Unit Price	Part No.	Unit Price	
1/8"	10-32	BCS 1/8 10-32	\$20.63	BTS 1/8 10-32	\$21.37	FCS 1/8 10-32	\$8.87	MCS 1/8 10-32	\$7.61	MES 1/8 10-32	\$15.14	RTS 1/8 10-32	\$21.37	TAS 1/8 10-32	\$5.30
1/8"	NPT1/8	BCS 1/8 N1/8	\$20.63	BTS 1/8 N1/8	\$21.37	FCS 1/8 N1/8	\$8.87	MCS 1/8 N1/8	\$7.61	MES 1/8 N1/8	\$15.14	RTS 1/8 N1/8	\$21.37	TAS 1/8 N1/8	\$5.30
1/8"	NPT1/4	BCS 1/8 N1/4	\$21.74	BTS 1/8 N1/4	\$22.45	FCS 1/8 N1/4	\$11.85	MCS 1/8 N1/4	\$7.61	MES 1/8 N1/4	\$17.32	RTS 1/8 N1/4	\$22.45		\$0.00
5/32"	10-32	BCS 5/32 10-32	\$20.63	BTS 5/32 10-32	\$21.37	FCS 5/32 10-32	\$8.87	MCS 5/32 10-32	\$7.61	MES 5/32 10-32	\$15.13	RTS 5/32 10-32	\$21.37	TAS 5/32 10-32	\$5.30
5/32"	NPT1/8	BCS 5/32 N1/8	\$20.63	BTS 5/32 N1/8	\$21.37	FCS 5/32 N1/8	\$8.87	MCS 5/32 N1/8	\$7.61	MES 5/32 N1/8	\$15.13	RTS 5/32 N1/8	\$21.37	TAS 5/32 N1/8	\$5.30
5/32"	NPT1/4	BCS 5/32 N1/4	\$20.63	BTS 5/32 N1/4	\$23.56	FCS 5/32 N1/4	\$8.87	MCS 5/32 N1/4	\$7.61	MES 5/32 N1/4	\$15.13	RTS 5/32 N1/4	\$23.56	TAS 5/32 N1/4	\$5.30
1/4"	NPT1/8	BCS 1/4 N1/8	\$23.40	BTS 1/4 N1/8	\$21.37	FCS 1/4 N1/8	\$8.87	MCS 1/4 N1/8	\$7.61	MES 1/4 N1/8	\$16.11	RTS 1/4 N1/8	\$21.37	TAS 1/4 N1/8	\$5.30
1/4"	NPT1/4	BCS 1/4 N1/4	\$23.40	BTS 1/4 N1/4	\$24.57	FCS 1/4 N1/4	\$8.87	MCS 1/4 N1/4	\$7.61	MES 1/4 N1/4	\$17.41	RTS 1/4 N1/4	\$24.57	TAS 1/4 N1/4	\$5.30
1/4"	NPT3/8	BCS 1/4 N3/8	\$24.49	BTS 1/4 N3/8	\$28.03	FCS 1/4 N3/8	\$9.55	MCS 1/4 N3/8	\$8.29	MES 1/4 N3/8	\$18.11	RTS 1/4 N3/8	\$28.03	TAS 1/4 N3/8	\$5.30
5/16"	NPT1/8	BCS 5/16 N1/8	\$24.49	BTS 5/16 N1/8	\$26.87	FCS 5/16 N1/8	\$12.53	MCS 5/16 N1/8	\$10.12	MES 5/16 N1/8	\$18.43	RTS 5/16 N1/8	\$26.87		\$0.00
5/16"	NPT1/4	BCS 5/16 N1/4	\$24.49	BTS 5/16 N1/4	\$26.87	FCS 5/16 N1/4	\$12.53	MCS 5/16 N1/4	\$10.12	MES 5/16 N1/4	\$19.02	RTS 5/16 N1/4	\$26.87	TAS 5/16 N1/4	\$7.82
5/16"	NPT3/8	BCS 5/16 N3/8	\$24.49	BTS 5/16 N3/8	\$30.88	FCS 5/16 N3/8	\$12.53	MCS 5/16 N3/8	\$10.69	MES 5/16 N3/8	\$19.45	RTS 5/16 N3/8	\$30.88	TAS 3/8 N1/8	\$7.82
5/16"	NPT1/2	BCS 5/16 N1/2	\$25.59	BTS 5/16 N1/2	\$31.98	FCS 5/16 N1/2	\$14.72	MCS 5/16 N1/2	\$11.56	MES 5/16 N1/2	\$23.46	RTS 5/16 N1/2	\$32.70		\$0.00
3/8"	NPT1/4	BCS 3/8 N1/4	\$27.27	BTS 3/8 N1/4	\$30.88	FCS 3/8 N1/4	\$15.20	MCS 3/8 N1/4	\$11.21	MES 3/8 N1/4	\$20.15	RTS 3/8 N1/4	\$25.93	TAS 3/8 N1/4	\$7.82
3/8"	NPT3/8	BCS 3/8 N3/8	\$27.27	BTS 3/8 N3/8	\$26.68	FCS 3/8 N3/8	\$16.48	MCS 3/8 N3/8	\$10.27	MES 3/8 N3/8	\$20.91	RTS 3/8 N3/8	\$26.68	TAS 3/8 N3/8	\$7.99
3/8"	NPT1/2	BCS 3/8 N1/2	\$27.27	BTS 3/8 N1/2	\$34.33	FCS 3/8 N1/2	\$17.05	MCS 3/8 N1/2	\$11.56	MES 3/8 N1/2	\$23.95	RTS 3/8 N1/2	\$34.33	TAS 3/8 N1/2	\$9.22
1/2"	NPT1/4	BCS 1/2 N1/4	\$29.41	BTS 1/2 N1/4	\$32.67	FCS 1/2 N1/4	\$16.50	MCS 1/2 N1/4	\$12.40	MES 1/2 N1/4	\$25.71	RTS 1/2 N1/4	\$32.67	TAS 1/2 N1/4	\$10.09
1/2"	NPT3/8	BCS 1/2 N3/8	\$30.50	BTS 1/2 N3/8	\$33.82	FCS 1/2 N3/8	\$17.05	MCS 1/2 N3/8	\$12.40	MES 1/2 N3/8	\$25.71	RTS 1/2 N3/8	\$33.82	TAS 1/2 N3/8	\$10.09
1/2"	NPT1/2	BCS 1/2 N1/2	\$32.70	BTS 1/2 N1/2	\$35.04	FCS 1/2 N1/2	\$17.61	MCS 1/2 N1/2	\$16.35	MES 1/2 N1/2	\$29.27	RTS 1/2 N1/2	\$36.13	TAS 1/2 N1/2	\$14.04
4 mm	M5	BCS 4 M5	\$20.63	BTS 4 M5	\$21.37	FCS 4 M5	\$8.87	MCS 4 M5	\$7.61	MES 4 M5	\$15.13	RTS 4 M5	\$21.37		
4 mm	R1/8	BCS 4 R1/8	\$20.63	BTS 4 R1/8	\$21.37	FCS 4 R1/8	\$8.87	MCS 4 R1/8	\$7.61	MES 4 R1/8	\$15.13	RTS 4 R1/8	\$21.37		
4 mm	R1/4	BCS 4 R1/4	\$20.63	BTS 4 R1/4	\$21.37	FCS 4 R1/4	\$8.87	MCS 4 R1/4	\$8.76	MES 4 R1/4	\$15.13	RTS 4 R1/4	\$21.37		
6mm	M5	BCS 6 M5	\$23.40	BTS 6 M5	\$21.37	FCS 6 M5	\$8.87	MCS 6 M5	\$8.76	MES 6 M5	\$17.41	RTS 6 M5	\$21.37		
6mm	R1/8	BCS 6 R1/8	\$23.40	BTS 6 R1/8	\$21.37	FCS 6 R1/8	\$8.87	MCS 6 R1/8	\$8.76	MES 6 R1/8	\$17.41	RTS 6 R1/8	\$21.37		
6mm	R1/4	BCS 6 R1/4	\$23.40	BTS 6 R1/4	\$24.57	FCS 6 R1/4	\$8.87	MCS 6 R1/4	\$8.76	MES 6 R1/4	\$17.41	RTS 6 R1/4	\$24.57		
8 mm	R1/4	BCS 8 R1/4	\$24.49	BTS 8 R1/4	\$26.87	FCS 8 R1/4	\$11.38	MCS 8 R1/4	\$10.12	MES 8 R1/4	\$19.33	RTS 8 R1/4	\$26.87		
8 mm	R3/8	BCS 8 R3/8	\$24.49	BTS 8 R3/8	\$29.18	FCS 8 R3/8	\$11.38	MCS 8 R3/8	\$10.69	MES 8 R3/8	\$19.45	RTS 8 R3/8	\$29.18		
10mm	R1/4	BCS 10 R1/4	\$27.27	BTS 10 R1/4	\$30.88	FCS 10 R1/4	\$12.53	MCS 10 R1/4	\$10.12	MES 10 R1/4	\$20.15	RTS 10 R1/4	\$30.88		
10mm	R3/8	BCS 10 R3/8	\$27.27	BTS 10 R3/8	\$30.88	FCS 10 R3/8	\$13.68	MCS 10 R3/8	\$10.27	MES 10 R3/8	\$20.91	RTS 10 R3/8	\$30.88		
12mm	R3/8	BCS 12 R3/8	\$30.50	BTS 12 R3/8	\$33.82	FCS 12 R3/8	\$14.61	MCS 12 R3/8	\$12.40	MES 12 R3/8	\$25.71	RTS 12 R3/8	\$33.82		
12mm	R1/2	BCS 12 R1/2	\$30.50	BTS 12 R1/2	\$36.13	FCS 12 R1/2	\$15.31	MCS 12 R1/2	\$16.35	MES 12 R1/2	\$29.27	RTS 12 R1/2	\$36.13		

Stainless Steel Fittings															
Name		Female Connector		Branch Tee (Swivel)		Female Connector		Male Connector		Male Elbow (Swivel)		Run Tee (Swivel)		Tube Adaptor	
Tube OD	U Thread	Part No.	Unit Price	Part No.	Unit Price	Part No.	Unit Price	Part No.	Unit Price	Part No.	Unit Price	Part No.	Unit Price	Part No.	Unit Price
5/32	U1/8"	BCS 5/32 U1/8		BTS 5/32 U1/8		FCS 5/32 U1/8		MCS 5/32 U1/8	\$10.90	MES 5/32 U1/8	\$18.42	RTS 5/32 U1/8		HBS MN1/4-FN1/8	\$2.92
1/4"	U1/8"	BCS 1/4 U1/8		BTS 1/4 U1/8		FCS 1/4 U1/8		MCS 1/4 U1/8	\$10.90	MES 1/4 U1/8	\$19.41	RTS 1/4 U1/8		HBS MN3/8-FN1/8	\$3.66
1/4"	U1/4"	BCS 1/4 U1/4		BTS 1/4 U1/4		FCS 1/4 U1/4		MCS 1/4 U1/4	\$10.90	MES 1/4 U1/4	\$20.70	RTS 1/4 U1/4		HBS MN3/8-FFN1/4	\$4.38
5/16	U1/4"	BCS 5/16 U1/4		BTS 5/16 U1/4		FCS 5/16 U1/4		MCS 5/16 U1/4	\$13.41	MES 5/16 U1/4	\$22.31	RTS 5/16 U1/4		HBS MN1/2-FN1/4	\$4.38
3/8"	U1/4"	BCS 3/8 U1/4		BTS 3/8 U1/4		FCS 3/8 U1/4		MCS 3/8 U1/4	\$13.41	MES 3/8 U1/4	\$23.44	RTS 3/8 U1/4		HBS MN1/2-FN3/8	\$4.38
3/8"	U3/8"	BCS 3/8 U3/8		BTS 3/8 U3/8		FCS 3/8 U3/8		MCS 3/8 U3/8	\$13.56	MES 3/8 U3/8	\$25.30	RTS 3/8 U3/8			
6	U1/8"	BCS 6 U1/8		BTS 6 U1/8		FCS 6 U1/8		MCS 6 U1/8	\$12.05	MES 6 U1/8	\$20.70	RTS 6 U1/8			
6	U1/4"	BCS 6 U1/4		BTS 6 U1/4		FCS 6 U1/4		MCS 6 U1/4	\$12.05	MES 6 U1/4	\$20.70	RTS 6 U1/4			
8	U1/4"	BCS 8 U1/4		BTS 8 U1/4		FCS 8 U1/4		MCS 8 U1/4	\$13.41	MES 8 U1/4	\$22.62	RTS 8 U1/4			

Nikel-Plated Brass Push-In Fittings List Price

Brass Fittings								
Model	Bulkhead Union		Elbow Union		Straight Union		Tee Union	
Tube OD	BUB		EUB		SUB		TUB	
1/8"	BUB 1/8	\$3.12	EUB 1/8	\$3.20	SUB 1/8	\$1.90	TUB 1/8	\$3.95
5/32"	BUB 5/32	\$2.66	EUB 5/32	\$3.20	SUB 5/32	\$1.90	TUB 5/32	\$3.95
1/4"	BUB 1/4	\$3.12	EUB 1/4	\$3.66	SUB 1/4	\$2.13	TUB 1/4	\$4.47
5/16"	BUB 5/16	\$3.20	EUB 5/16	\$3.66	SUB 5/16	\$2.13	TUB 5/16	\$5.25
3/8"	BUB 3/8	\$4.94	EUB 3/8	\$4.80	SUB 3/8	\$2.97	TUB 3/8	\$6.00
1/2"	BUB 1/2	\$5.48	EUB 1/2	\$5.17	SUB 1/2	\$3.66	TUB 1/2	\$6.99
4 mm	BUB 4	\$2.66	EUB 4	\$3.20	SUB 4	\$1.90	TUB 4	\$3.95
6 mm	BUB 6	\$3.12	EUB 6	\$3.66	SUB 6	\$2.13	TUB 6	\$4.47
8 mm	BUB 8	\$3.21	EUB 8	\$3.66	SUB 8	\$2.13	TUB 8	\$5.25

Brass Fittings										
Model	Branch Tee		Female Connector		Male Connector		Male Elbow (Swivel)		Y Connector (Swivel)	
Tube OD X Thread	BTB		FCB		MCB		MEB		YCB	
1/8" X 10-32	BTB 1/8 10-32	\$3.80	FCB 1/8 10-32	\$1.60	MCB 1/8 10-32	\$1.82	MEB 1/8 10-32	\$3.12	YCB 1/8 10-32	\$4.26
1/8" X 1/8" NPT	BTB 1/8 N1/8	\$3.80	FCB 1/8 N1/8	\$1.60	MCB 1/8 N1/8	\$1.55	MEB 1/8 N1/8	\$3.20	YCB 1/8 N1/8	\$4.26
5/32" X 10-32	BTB 5/32 10-32	\$3.80	FCB 5/32 10-32	\$1.60	MCB 5/32 10-32	\$1.60	MEB 5/32 10-32	\$3.12	YCB 5/32 10-32	\$4.26
5/32" X 1/8" NPT	BTB 5/32 N1/8	\$3.80	FCB 5/32 N1/8	\$1.60	MCB 5/32 N1/8	\$1.60	MEB 5/32 N1/8	\$3.20	YCB 5/32 N1/8	\$4.26
1/4" X 1/8" NPT	BTB 1/4 N1/8	\$4.41	FCB 1/4 N1/8	\$1.60	MCB 1/4 N1/8	\$1.60	MEB 1/4 N1/8	\$3.50	YCB 1/4 N1/8	\$4.94
1/4" X 1/4" NPT	BTB 1/4 N1/4	\$4.41	FCB 1/4 N1/4	\$1.82	MCB 1/4 N1/4	\$1.82	MEB 1/4 N1/4	\$3.80	YCB 1/4 N1/4	\$4.94
1/4" X 3/8" NPT	BTB 1/4 N3/8	\$4.41	FCB 1/4 N3/8	\$2.13	MCB 1/4 N3/8	\$2.13	MEB 1/4 N3/8	\$4.18	YCB 1/4 N3/8	\$5.17
5/16" X 1/4" NPT	BTB 5/16 N1/4	\$4.41	FCB 5/16 N1/4	\$2.13	MCB 5/16 N1/4	\$2.05	MEB 5/16 N1/4	\$4.73	YCB 5/16 N1/4	\$5.63
5/16" X 3/8" NPT	BTB 5/16 N3/8	\$5.71	FCB 5/16 N3/8	\$2.20	MCB 5/16 N3/8	\$2.20	MEB 5/16 N3/8	\$4.80	YCB 5/16 N3/8	\$0.00
3/8" X 1/4" NPT	BTB 3/8 N1/4	\$5.71	FCB 3/8 N1/4	\$2.20	MCB 3/8 N1/4	\$2.36	MEB 3/8 N1/4	\$5.17	YCB 3/8 N1/4	\$6.46
3/8" X 3/8" NPT	BTB 3/8 N3/8	\$5.71	FCB 3/8 N3/8	\$2.20	MCB 3/8 N3/8	\$2.51	MEB 3/8 N3/8	\$5.32	YCB 3/8 N3/8	\$6.54
3/8" X 1/2" NPT	BTB 3/8 N1/2	\$5.71	FCB 3/8 N1/2	\$3.32	MCB 3/8 N1/2	\$3.34	MEB 3/8 N1/2	\$5.94	YCB 3/8 N1/2	\$6.84
1/2" X 3/8" NPT	BTB 1/2 N3/8	\$5.76	FCB 1/2 N3/8	\$2.65	MCB 1/2 N3/8	\$2.66	MEB 1/2 N3/8	\$5.78	YCB 1/2 N3/8	\$0.00
1/2" X 1/2" NPT	BTB 1/2 N1/2	\$6.23	FCB 1/2 N1/2	\$2.92	MCB 1/2 N1/2	\$3.66	MEB 1/2 N1/2	\$6.23	YCB 1/2 N1/2	\$6.84
4 mm X M5	BTB 4 M5	\$3.80	FCB 4 M5	\$1.37	MCB 4 M5	\$1.37	MEB 4 M5	\$1.37	YCB 4 M5	\$4.26
4 X 1/8" NPT	BTB 4 N1/8	\$3.80	FCB 4 N1/8	\$1.37	MCB 4 N1/8	\$1.37	MEB 4 N1/8	\$3.20	YCB 4 N1/8	\$4.26
8 mm X 1/4" NPT	BTB 8 N1/4	\$4.41	FCB 8 N1/4	\$2.13	MCB 8 N1/4	\$2.36	MEB 8 N1/4	\$4.73	YCB 8 N1/4	
8 mm X 3/8" NPT	BTB 8 N3/8	\$4.41	FCB 8 N3/8	\$2.20	MCB 8 N3/8	\$2.20	MEB 8 N3/8	\$4.80	YCB 8 N3/8	

Stainless Steel & Nickel-Plated Brass Push-In Fittings Specifications



A. Installation of Pipe Fittings:

1. Tighten fitting by hand, then turn it 2-3 turns with a wrench until it reaches the desire torque listed. If the fitting is not pre-coated with sealant, or is used and the sealant is not in good condition, apply Teflon sealant tape to the threads.

Recommendation of Torque for Tightening Fittings		
Fitting Thread Size	Torque, lb-ft	Torque, kgf/cm
10-32, M5 -M6	1.0 -1.5	14 -21
NPT1/8, R1/8	5 -6.5	70 -90
NPT1/4, R1/4	8.5 -10	120 -140
NPT3/8, R3/8	16 -17.5	220 -240
NPT1/2, R1/2	20 -21.5	280 -300

B. Installation of Tubing into Fitting:

1. Slowly push a clean and perpendicularly cut tubing into the fitting until it comes to a dead stop.
2. Pull the tubing back gently until the Grip Ring or Collet of the fitting grips onto the tubing and has a good seal.
3. Use Polyethylene, Polypropylene, Polyurethane or Nylon Tubing designed for instant fittings.
4. Hard metal tubing can be used for all metal Stainless Steel and all Brass fittings if the tubing is pre-grooved.

C. Removal of Tubing from Fitting:

1. Push in evenly on the two long oval sides of the Release Button.
2. Pull out the tube while depressing the Release Button.
3. To reuse the tubing, cut off the lodged portion of the previously used tubing in an even and perpendicular fashion.

D. Recommended Tubing Material, Size and Hardness Requirements:

Tubing Material	Specified Size	Hardness (Durometer)
Polyurethane	+/- 0.006" (+/-0.15 mm)	Shore A 85 or higher
Polyethylene	+/- 0.004" (+/-0.1 mm)	Shore D 44—D75
Polypropylene	+/- 0.004" (+/-0.1 mm)	Shore D 44—D75
Nylon	+/- 0.004" (+/-0.1 mm)	Shore D 44—D75
Pre-grooved Metal Tubing	+/- 0.004" (+/-0.1 mm)	

E. Specifications, Materials of Construction and Schematic of Typical Construction:

	Stainless Steel Fittings	Nickel-Plated Brass Fittings
Operating Pressure	0 - 250 PSI (0 - 1650 kpa)	0 - 250 PSI (0 - 1650 kpa)
Vacuum	0 - 30" Hg (0 - 760 mm Hg)	0 - 30" Hg (0 - 760 mm Hg)
Operating Temperature	5 - 230 °F (-15 to 110 °C)	5 - 230 °F (-15 to 110 °C)
Recommended Tubing Material	Polyurethane, Nylon, Polyethylene, Polypropylene, and Hard metal tubing (tubing must be pre-grooved)	
Metal Body	T316 Stainless Steel	Nickel-Plated Brass
Plastic Body	None	None
Release Button	300 series Stainless Steel	Nickel-Plated Brass
Grip Ring or Collet	300 series Stainless Steel	300 series Stainless Steel
O-ring	VITON	NBR
Thread Sealant	None	Teflon
Service	Air, Liquid	Air, Liquid
Sterilization Temperature	Up to 280°F (138°C)	

Gripper Style SS Fitting

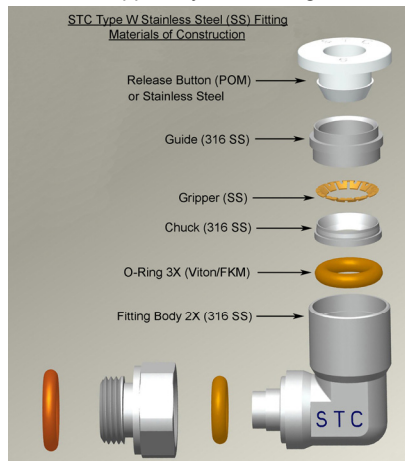

Collet Style SS Fitting

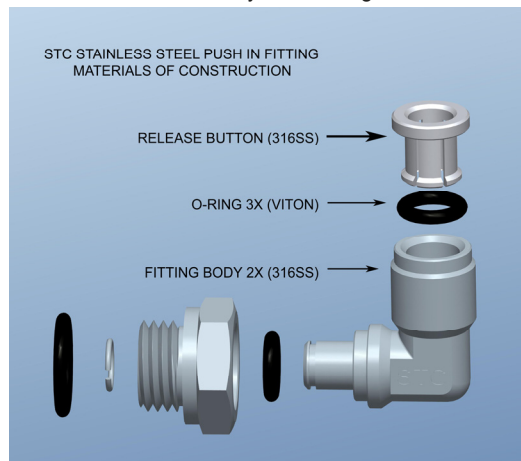

Stainless Steel & Nickel-Plated Brass Push-In Fittings Dimensions

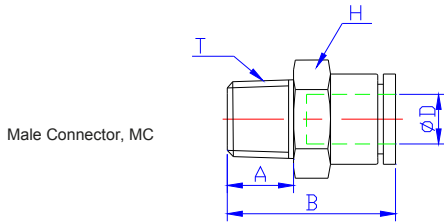

Male Connector, MC

Part No.	Part No.	ΦD	Pipe Size	A	B	H
MCB 1/8 10-32	MCS 1/8 10-32	1/8	10-32	5	20	S11
MCB 1/8 N1/8	MCS 1/8 N1/8	1/8	1/8 NPT	8	17	S11
MCB 1/8 N1/4	MCS 1/8 N1/4	1/8	1/4 NPT	11	21	S14
MCB 5/32 10-32	MCS 5/32 10-32	5/32	10-32	5	20	S10
MCB 5/32 N1/8	MCS 5/32 N1/8	5/32	1/8 NPT	8	17	S11
MCB 1/4 N1/8	MCS 1/4 N1/8	1/4	1/8 NPT	8	21	S12
MCB 1/4 N1/4	MCS 1/4 N1/4	1/4	1/4 NPT	11	21	S14
MCB 1/4 N3/8	MCS 1/4 N3/8	1/4	3/8 NPT	12.5	22.5	S17
MCB 1/4 10-32	MCS 1/4 10-32	1/4	10-32	5	23	S12
MCB 5/16 N1/4	MCS 5/16 N1/4	5/16	1/4 NPT	11	25.5	S14
MCB 5/16 N3/8	MCS 5/16 N3/8	5/16	3/8 NPT	12.5	24	S17
MCB 3/8 N1/8	MCS 3/8 N1/8	3/8	1/8 NPT	9	29	S17
MCB 3/8 N1/4	MCS 3/8 N1/4	3/8	1/4 NPT	11	27	S17
MCB 3/8 N3/8	MCS 3/8 N3/8	3/8	3/8 NPT	12.5	26	S17
MCB 3/8 N1/2	MCS 3/8 N1/2	3/8	1/2 NPT	15	28	S22
MCB 1/2 N1/4	MCS 1/2 N1/4	1/2	1/4 NPT	11	33	S19
MCB 1/2 N3/8	MCS 1/2 N3/8	1/2	3/8 NPT	12.5	29.8	S19
MCB 1/2 N1/2	MCS 1/2 N1/2	1/2	1/2 NPT	15	30.4	S22
MCB 4 M5	MCS 4 M5	4mm	M5	5	20	S10
MCB 4 N1/8	MCS 4 N1/8	4mm	1/8 NPT	8	17	S10
MCS 8 N1/4	MCS 8 N1/4	8mm	1/4 NPT	11	25.5	S14
MCS 8 N3/8	MCS 8 N3/8	8mm	3/8 NPT	12.5	24	S17

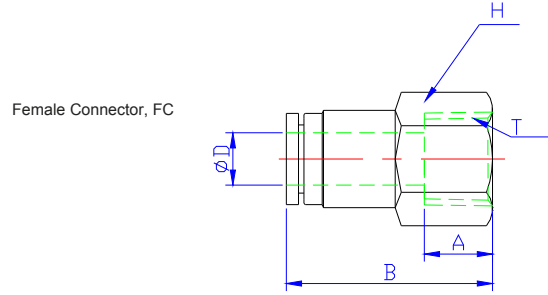

Female Connector, FC

Part No.	Part No.	ΦD	T, Thread	A	B	H
FCB 1/8 10-32	FCS 1/8 10-32	1/8	10-32	5.4	21	S12
FCB 1/8 N1/8	FCS 1/8 N1/8	1/8	1/8 NPT	9	22	S14
FCB 5/32 10-32	FCS 5/32 10-32	5/32	10-32	5.4	21	S12
FCB 5/32 N1/8	FCS 5/32 N1/8	5/32	1/8 NPT	9	22	S14
FCB 1/4 N1/8	FCS 1/4 N1/8	1/4	1/8 NPT	9	25.7	S14
FCB 1/4 N1/4	FCS 1/4 N1/4	1/4	1/4 NPT	12	28.7	S17
FCB 1/4 N3/8	FCS 1/4 N3/8	1/4	3/8 NPT	12.5	29.2	S19
FCB 5/16 N1/4	FCS 5/16 N1/4	5/16	1/4 NPT	12	31.5	S17
FCB 3/8 N1/4	FCS 3/8 N1/4	3/8	1/4 NPT	12	31	S17
FCB 3/8 N3/8	FCS 3/8 N3/8	3/8	3/8 NPT	12.5	33	S19
FCB 3/8 N1/2	FCS 3/8 N1/2	3/8	1/2 NPT	14.7	35.5	S24
FCB 1/2 N1/4	FCS 1/2 N1/4	1/2	1/4 NPT	12	33.2	S19
FCB 1/2 N3/8	FCS 1/2 N3/8	1/2	3/8 NPT	12.5	33.7	S19
FCB 1/2 N1/2	FCS 1/2 N1/2	1/2	1/2 NPT	15.8	37	S24
FCB 4 M5	FCS 4 M5	4	M5	5.4	21	S12
FCB 4 N1/8	FCS 4 N1/8	4	1/8 NPT	9	22	S14
FCB 8 N1/4	FCS 8 N1/4	8	1/4 NPT	12	31.5	S17
FCB 8 N3/8	FCS 8 N3/8	8	3/8 NPT	12.5	32.5	S19

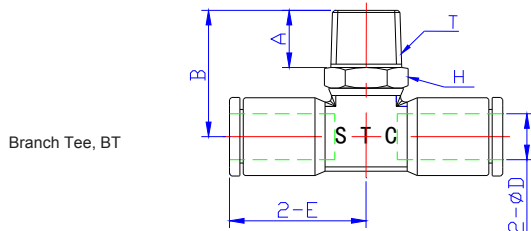

Branch Tee, BT

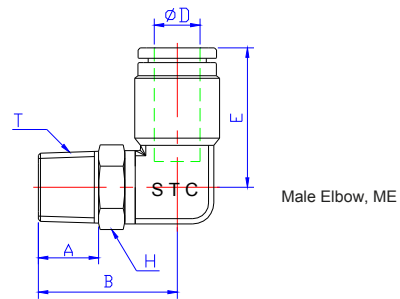

Male Elbow, ME

ΦD	T, Thread	H	Part No.	Part No.	A	B	E	Part No.	Part No.	A	B	E
1/8	10-32	S11	BTB 1/8 10-32	BTS 1/8 10-32	5.4	19.4	16.2	MEB 1/8 10-32	MES 1/8 10-32	5.4	19.4	16.2
1/8	1/8 NPT	S11	BTB 1/8 N1/8	BTS 1/8 N1/8	8.2	22.4	16.2	MEB 1/8 N1/8	MES 1/8 N1/8	8.1	18.8	16.2
5/32"	10-32	S11	BTB 5/32 10-32	BTS 5/32 10-32	5.4	19.4	16.2	MEB 5/32 10-32	MES 5/32 10-32	5.4	19.5	16.2
5/32"	1/8 NPT	S11	BTB 5/32 N1/8	BTS 5/32 N1/8	8.2	19.4	16.2	MEB 5/32 N1/8	MES 5/32 N1/8	8.1	19.1	16.2
1/4"	1/8 NPT	S11	BTB 1/4 N1/8	BTS 1/4 N1/8	8.2	21	20	MEB 1/4 N1/8	MES 1/4 N1/8	8.1	21	17.5
1/4"	1/4 NPT	S14	BTB 1/4 N1/4	BTS 1/4 N1/4	11.5	24.7	20	MEB 1/4 N1/4	MES 1/4 N1/4	11.5	25.3	17.5
1/4"	3/8 NPT	S17	BTB 1/4 N3/8	BTS 1/4 N3/8	12	25.2	20	MEB 1/4 N3/8	MES 1/4 N3/8	12	25.8	17.5
5/16"	1/4 NPT	S14	BTB 5/16 N1/4	BTS 5/16 N1/4	11.5	25.9	21.5	MEB 5/16 N1/4	MES 5/16 N1/4	11.5	26.6	22.5
5/16"	3/8 NPT	S17	BTB 5/16 N3/8	BTS 5/16 N3/8	12	26.4	21.5					
3/8"	1/4 NPT	S14	BTB 3/8 N1/4	BTS 3/8 N1/4	11.5	27.5	25.5	MEB 3/8 N1/4	MES 3/8 N1/4	11.5	26.5	25.8
3/8"	3/8 NPT	S17	BTB 3/8 N3/8	BTS 3/8 N3/8	12	28	25.5	MEB 3/8 N3/8	MES 3/8 N3/8	12	27	25.8
3/8"	1/2 NPT	S22	BTB 3/8 N1/2	BTS 3/8 N1/2	15	31	25.5	MEB 3/8 N1/2	MES 3/8 N1/2	15	30	25.8
1/2"	1/4 NPT	S14	BTB 1/2 N1/4	BTS 1/2 N1/4	15	28.8	27.5	MEB 1/2 N1/4	MES 1/2 N1/4	11.5	27.8	27.4
1/2"	3/8 NPT	S17	BTB 1/2 N3/8	BTS 1/2 N3/8	12	29.3	27.5	MEB 1/2 N3/8	MES 1/2 N3/8	12	28.3	27.4
1/2"	1/2 NPT	S22	BTB 1/2 N1/2	BTS 1/2 N1/2	15	32.3	27.5	MEB 1/2 N1/2	MES 1/2 N1/2	15	31.3	27.4
4	M5	S11	BTB 4 M5	BTS 4 M5	5.4	19.4	16.2	MEB 4 M5	MES 4 M5	5.4	19.5	16.2
4	1/8 NPT	S11	BTB 4 N1/8	BTS 4 N1/8	8.2	22.4	16.2	MEB 4 N1/8	MES 4 N1/8	8.2	18.8	16.2
8	1/4 NPT	S14	BTB 8 N1/4	BTS 8 N1/4	11.5	25.9	21.5	MEB 8 N1/4	MES 8 N1/4	11.5	26.6	22.5
8	3/8 NPT	S17	BTB 8 N3/8	BTS 8 N3/8	12	26.4	21.5	MEB 8 N3/8	MES 8 N3/8	12	27.1	22.5

Units in mm

Stainless Steel & Nickel-Plated Brass Push-In Fittings Dimensions

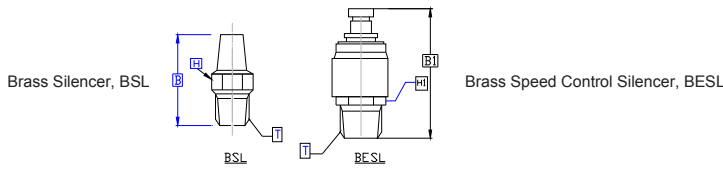

Part No.	Part No.	Port NPT	A	B	H	B1	H1
BSL-N1/8	BESL-N1/8	1/8	0.39	0.99	0.47	1.37	0.47
BSL-N1/4	BESL-N1/4	1/4	0.47	1.28	0.59	1.56	0.55
BSL-N3/8	BESL-N3/8	3/8	0.53	1.60	0.75	1.77	0.66
BSL-N1/2	BESL-N1/2	1/2	0.59	1.85	0.86	2.31	0.94

Bulkhead Union, BU

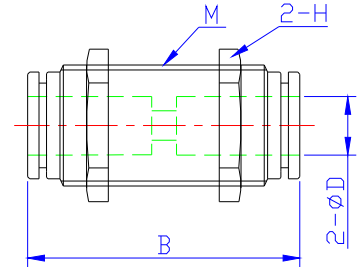

Part No.	Part No.	ΦD	B	M	H
BUB 1/8	BUS 1/8	1/8	30.7	M10X1	S12
BUB 5/32	BUS 5/32	5/32	30.7	M10X1	S12
BUB 1/4	BUS 1/4	1/4	35.5	M12X1	S17
BUB 5/16	BUS 5/16	5/16	37	M17X1	S19
BUB 3/8	BUS 3/8	3/8	39	M17X1	S19
BUB 1/2	BUS 1/2	1/2	44	M21X1	S23
BUB 4	BUS 4	4	30.7	M10X1	S12
BUB 6	BUS 6	6	35.5	M12X1	S17
BUB 8	BUS 8	8	37	M17X1	S19
BUB 10	BUS 10	10			
BUB 12	BUS 12	12			

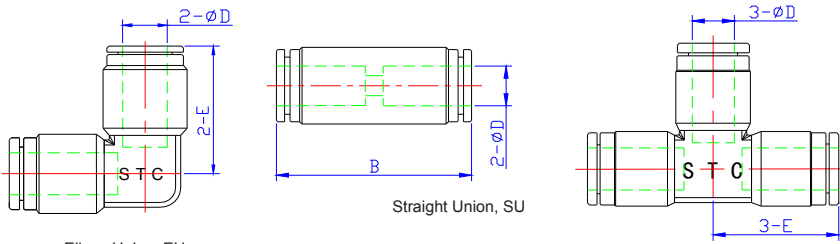

Elbow Union, EU

Tee Union, TU

ΦD	Part No.	Part No.	E	Part No.	Part No.	B	Part No.	Part No.	E
1/8	EUB 1/8	EUS 1/8	16.2	SUB 1/8	SUS 1/8	35.5	TUB 1/8	TUS 1/8	16.25
5/32	EUB 5/32	EUS 5/32	16.2	SUB 5/32	SUS 5/32	35.5	TUB 5/32	TUS 5/32	16.25
1/4	EUB 1/4	EUS 1/4	17.5	SUB 1/4	SUS 1/4	35.5	TUB 1/4	TUS 1/4	20
5/16	EUB 5/16	EUS 5/16	22.5	SUB 5/16	SUS 5/16	37	TUB 5/16	TUS 5/16	22.6
3/8	EUB 3/8	EUS 3/8	25.8	SUB 3/8	SUS 3/8	44	TUB 3/8	TUS 3/8	25.5
1/2	EUB 1/2	EUS 1/2	27.4	SUB 1/2	SUS 1/2	42.4	TUB 1/2	TUS 1/2	27.5
4mm	EUB 4	EUS 4	16.2	SUB 4	SUS 4		TUB 4	TUS 4	16.25
6mm	EUB 6	EUS 6		SUB 6	SUS 6	35.5	TUB 6	TUS 6	
8mm	EUB 8	EUS 8	22.5	SUB 8	SUS 8	37	TUB 8	TUS 8	22.6
10mm	EUB 10	EUS 10		SUB 10	SUS 10		TUB 10	TUS 10	
12mm	EUB 12	EUS 12		SUB 12	SUS 12		TUB 12	TUS 12	

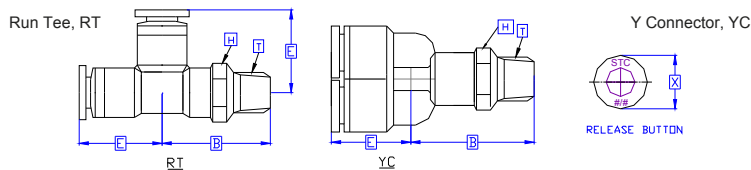

Run Tee, RT

Y Connector, YC

RELEASE BUTTON

Part No.	Part No.	Part No.	Part No.	Tube OD	T, Thread	A	B	H	E	X
RTB 5/32 10-32	RTS 5/32 10-32	YCB 5/32 10-32	YCS 5/32 10-32	5/32	10-32	0.24	0.99	0.31	0.81	0.39
RTB 5/32 N1/8	RTS 5/32 N1/8	YCB 5/32 N1/8	YCS 5/32 N1/8	5/32	1/8 NPT	0.39	0.86	0.47	0.81	0.39
RTB 1/4 N1/8	RTS 1/4 N1/8	YCB 1/4 N1/8	YCS 1/4 N1/8	1/4	1/8 NPT	0.37	0.85	0.47	0.97	0.47
RTB 1/4 N1/4	RTS 1/4 N1/4	YCB 1/4 N1/4	YCS 1/4 N1/4	1/4	1/4 NPT	0.51	1.02	0.55	0.97	0.47
RTB 1/4 N3/8	RTS 1/4 N3/8	YCB 1/4 N3/8	YCS 1/4 N3/8	1/4	3/8 NPT	0.53	1.14	0.67	0.97	0.47
RTB 5/16 N1/4	RTS 5/16 N1/4	YCB 5/16 N1/4	YCS 5/16 N1/4	5/16	1/4 NPT	0.50	1.09	0.55	1.18	0.67
RTB 5/16 N3/8	RTS 5/16 N3/8	YCB 5/16 N3/8	YCS 5/16 N3/8	5/16	3/8 NPT	0.53	1.09	0.67	1.18	0.67
RTB 3/8 N1/4	RTS 3/8 N1/4	YCB 3/8 N1/4	YCS 3/8 N1/4	3/8	1/4 NPT	0.50	1.09	0.55	1.18	0.67
RTB 3/8 N3/8	RTS 3/8 N3/8	YCB 3/8 N3/8	YCS 3/8 N3/8	3/8	3/8 NPT	0.53	1.09	0.67	1.18	0.67
RTB 3/8 N1/2	RTS 3/8 N1/2	YCB 3/8 N1/2	YCS 3/8 N1/2	3/8	1/2 NPT	0.60	1.18	0.87	1.18	0.67
RTB 1/2 N3/8	RTS 1/2 N3/8	YCB 1/2 N3/8	YCS 1/2 N3/8	1/2	3/8 NPT	0.53	1.17	0.67	1.28	0.75
RTB 1/2 N1/2	RTS 1/2 N1/2	YCB 1/2 N1/2	YCS 1/2 N1/2	1/2	1/2 NPT	0.60	1.26	0.86	1.28	0.75
RTB 4 M5	RTS 4 M5	YCB 4 M5	YCS 4 M5	4mm	M5	0.24	0.99	0.31	0.81	0.39
RTB 4 N1/8	RTS 4 N1/8	YCB 4 N1/8	YCS 4 N1/8	4mm	1/8 NPT	0.39	0.86	0.47	0.81	0.39
RTB 8 N1/4	RTS 8 N1/4	YCB 8 N1/4	YCS 8 N1/4	8mm	1/4 NPT	0.50	1.09	0.55	1.18	0.67
RTB 8 N3/8	RTS 8 N3/8	YCB 8 N3/8	YCS 8 N3/8	8mm	3/8 NPT	0.53	1.09	0.67	1.18	0.67

Units in mm

STC-Lok™ Compression Fittings Numbering System

Ordering Part No. =
(eg. MCC 1/4 N1/8)

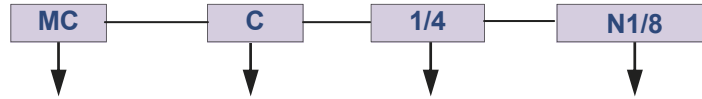

Fitting Name	Model	Material/Type	Tube OD	Thread Size	Features
BACK FERRULE	BF	C = 316 Stainless Steel Double Ferrule Compression Fittings	(inch)	Pipe Thread Sizes: N= NPT N1/8 N1/4 N3/8 N1/2 N3/4 N1 R= BSPT R1/8 R1/4 R3/8 R1/2 R3/4 R1 Machine Threads 10-32 M5 M6	316 Stainless Steel Compression Fittings with Double Ferrules, Compatible with Swagelok®, Parker A-Lok, Let-Lok, Yor-Lok
BRANCH TEE	BT				
BULKHEAD UNION	BU				
CAP	CP				
ELBOW UNION	EU				
FEMALE CONNECTOR	FC				
FRONT FERRULE	FF				
MALE CONNECTOR	MC				
MALE ELBOW	ME				
NUT	NT				
PLUG	PG				
REDUCED UNION	RU				
RUN TEE	RT				
STRAIGHT UNION	SU				
TEE UNION	TU				
TUBE ADAPTOR	TA				
TUBE STEM REDUCER	TS				

SPECIFICATIONS

Operating Temperature	-425 to 600 °F
Material of Construction	316 stainless Steel
Compatible with	Swagelok®, Parker A-Lok, Let-Lock, Yor-Lok
Service	air, water, steam, oil, gasoline, natural gas, most solvent and acids that are compatible with 316 stainless steel.

PRESSURE

Tube Size (OD)		Maximum Pressure (PSI @72 °F)*
1/16"		10000
1/8"	2 mm	8800
3/16"	4 mm	5500
1/4"	6 mm	4200
5/16"	8 mm	3300
3/8"	10 mm	2800
1/2"	12 mm	2500
5/8"	16 mm	2300
3/4"	18 mm	2100
1"	20 mm	1900

* Maximum pressures are based on Type 304 and 316 annealed stainless steel welded tubing made to ASTM A213, A249, or A269 standards.

STC Stainless Steel Compression Fittings List Price









Compression Fittings												
	Bulkhead Union		Straight Union		Elbow Union		Tee Union		Cross Union		Reducing Union	
Name	Part No.	Unit Price	Part No.	Unit Price	Part No.	Unit Price	Part No.	Unit Price	Part No.	Unit Price	Part No.	Unit Price
1/8"	BUC 1/8	\$25.84	SUC 1/8	\$12.85	EUC 1/8	\$17.52	TUC 1/8	\$28.01	CUC 1/8	\$57.89	RUC 1/8X1/16	\$18.88
3/16"	BUC 3/16		SUC 3/16		EUC 3/16		TUC 3/16				RUC 3/16X1/16	
1/4"	BUC 1/4	\$18.33	SUC 1/4	\$11.88	EUC 1/4	\$17.77	TUC 1/4	\$24.34	CUC 1/4	\$46.96	RUC 3/16X1/8	\$12.30
5/16"	BUC 5/16	\$24.79	SUC 5/16	\$14.46	EUC 5/16	\$22.21	TUC 5/16	\$30.28	CUC 5/16	\$52.76	RUC 1/4X1/16	\$16.95
3/8"	BUC 3/8	\$26.57	SUC 3/8	\$16.87	EUC 3/8	\$21.12	TUC 3/8	\$32.00	CUC 3/8	\$66.31	RUC 1/4X1/8	\$13.42
1/2"	BUC 1/2	\$38.31	SUC 1/2	\$25.58	EUC 1/2	\$34.92	TUC 1/2	\$46.75	CUC 1/2	\$68.82	RUC 1/4X3/16	\$15.48
5/8"	BUC 5/8	\$56.87	SUC 5/8	\$35.10	EUC 5/8	\$47.16	TUC 5/8	\$56.99	CUC 5/8	\$102.14	RUC 5/16X1/4	\$14.92
3/4"	BUC 3/4	\$63.72	SUC 3/4	\$42.67	EUC 3/4	\$62.05	TUC 3/4	\$73.04	CUC 3/4	\$135.80	RUC 3/8X1/16	\$25.68
1	BUC 1	\$126.48	SUC 1	\$74.25	EUC 1	\$126.48	TUC 1	\$161.70	CUC 1	\$242.39	RUC 3/8X1/8	\$22.89
											RUC 3/8X1/4	\$17.49
											RUC 3/8X5/16	\$20.96
											RUC 1/2X1/8	\$37.61
4 mm	BUC 4	\$26.60	SUC 4	\$12.00	EUC 4	\$25.41	TUC 4	\$28.77			RUC 1/2X1/4	\$28.01
6 mm	BUC 6	\$18.33	SUC 6	\$11.88	EUC 6	\$17.77	TUC 6	\$24.34	CUC 6	\$46.96	RUC 1/2X3/8	\$27.31
8 mm	BUC 8	\$24.79	SUC 8	\$14.46	EUC 8	\$22.21	TUC 8	\$30.28	CUC 8	\$52.76	RUC 5/8X3/8	\$42.14
10 mm	BUC 10	\$26.57	SUC 10	\$16.87	EUC 10	\$21.12	TUC 10	\$32.00	CUC 10	\$66.31	RUC 5/8X1/2	\$41.43
12 mm	BUC 12	\$38.31	SUC 12	\$25.58	EUC 12	\$34.92	TUC 12	\$46.75	CUC 12	\$68.82	RUC 3/4X3/8	\$57.53

Compression Fittings														
	CAP		Back Ferrule		Front Ferrule		Nut		Plug		Tube Stem Reducer		Tube X Male Pipe (Butt Weld)	
Tube OD	Part No.	Unit Price	Part No.	Unit Price	Part No.	Unit Price	Part No.	Unit Price	Part No.	Unit Price	Part No.	Unit Price	Part No.	Unit Price
1/8"	CPC 1/8	\$8.46	BFC 1/8	\$2.29	FFC 1/8	\$2.53	NTC 1/8	\$2.79	PGC 1/8	\$8.37	TRC 1/16X1/8	\$17.78	BWC 1/8X1/8	\$8.80
3/16"	CPC 3/16		BFC 3/16		FFC 3/16		NTC 3/16		PGC 3/16		TRC 1/8X1/16		BWC 3/16X1/8	
1/4"	CPC 1/4	\$7.17	BFC 1/4	\$1.92	FFC 1/4	\$2.09	NTC 1/4	\$2.51	PGC 1/4	\$6.43	TRC 1/4X1/8	\$13.19	BWC 1/4X1/8	\$8.55
5/16"	CPC 5/16	\$7.64	BFC 5/16	\$2.33	FFC 5/16	\$2.55	NTC 5/16	\$2.69	PGC 5/16	\$7.46	TRC 1/4X3/8	\$10.60	BWC 1/4X1/4	\$8.97
3/8"	CPC 3/8	\$9.55	BFC 3/8	\$2.27	FFC 3/8	\$2.50	NTC 3/8	\$3.41	PGC 3/8	\$7.54	TRC 1/4X1/2	\$12.45	BWC 5/16X1/4	\$14.07
1/2"	CPC 1/2	\$14.33	BFC 1/2	\$3.35	FFC 1/2	\$3.58	NTC 1/2	\$5.58	PGC 1/2	\$10.74	TRC 5/16X1/4	\$14.83	BWC 3/8X3/8	\$14.36
5/8"	CPC 5/8	\$18.03	BFC 5/8	\$3.93	FFC 5/8	\$4.16	NTC 5/8	\$8.05	PGC 5/8	\$16.65	TRC 3/8X1/4	\$13.14	BWC 3/8X1/2	\$19.76
3/4"	CPC 3/4	\$24.21	BFC 3/4	\$4.92	FFC 3/4	\$5.55	NTC 3/4	\$9.60	PGC 3/4	\$17.92	TRC 3/8X1/2	\$13.14	BWC 1/2X1/2	\$19.41
1	CPC 1	\$45.11	BFC 1	\$8.49	FFC 1	\$11.55	NTC 1	\$18.28	PGC 1	\$34.88	TRC 1/2X3/4	\$18.61	BWC 1/2X3/4	\$28.87
4 mm	CPC 4	\$8.35	BFC 4	\$2.32	FFC 4	\$2.55	NTC 4	\$2.51	PGC 4	\$8.64			BWC 5/8X1/2	\$22.35
6 mm	CPC 6	\$7.17	BFC 6	\$1.92	FFC 6	\$2.09	NTC 6	\$2.51	PGC 6	\$6.43			BWC 3/4X3/4	\$32.65
8 mm	CPC 8	\$7.64	BFC 8	\$2.33	FFC 8	\$2.55	NTC 8	\$2.69	PGC 8	\$7.46			BWC 1X1	\$63.15
10 mm	CPC 10	\$9.55	BFC 10	\$2.27	FFC 10	\$2.50	NTC 10	\$3.41	PGC 10	\$7.54				
12 mm	CPC 12	\$14.33	BFC 12	\$3.35	FFC 12	\$3.58	NTC 12	\$5.58	PGC 12	\$10.74				



STC Stainless Steel Compression Fittings List Price

Compression Fittings													
	Name	Branch Tee		Female Connector		Female Branch Tee		Male Connector		Male Elbow		Run Tee	
Tube OD	Thread	Part No.	Unit Price	Part No.	Unit Price	Part No.	Unit Price	Part No.	Unit Price	Part No.	Unit Price	Part No.	Unit Price
1/8"	10-32UNF												
1/8"	NPT1/8"	BTC 1/8 N1/8	\$28.06	FCC 1/8 N1/8	\$12.49	FBC 1/8 N1/8	\$36.64	MCC 1/8 N1/8	\$9.45	MEC 1/8 N1/8	\$15.62	RTC 1/8 N1/8	\$28.44
1/8"	NPT1/4"	BTC 1/8 N1/4	\$31.77	FCC 1/8 N1/4	\$14.57	FBC 1/8 N1/4	\$36.12	MCC 1/8 N1/4	\$10.40	MEC 1/8 N1/4	\$14.95	RTC 1/8 N1/4	\$47.53
3/16"	10-32UNF												
3/16"	NPT1/8"	BTC 3/16 N1/8		FCC 3/16 N1/8				MCC 3/16 N1/8		MEC 3/16 N1/8		RTC 3/16 N1/8	
3/16"	NPT1/4"									MEC 3/16 N1/4	\$17.52		
3/16"	NPT3/8"												
1/4"	10-32UNF												
1/4"	NPT1/8"	BTC 1/4 N1/8	\$26.50	FCC 1/4 N1/8	\$10.60	FBC 1/4 N1/8	\$33.64	MCC 1/4 N1/8	\$8.18	MEC 1/4 N1/8	\$13.50	RTC 1/4 N1/8	\$26.93
1/4"	NPT1/4"	BTC 1/4 N1/4	\$31.89	FCC 1/4 N1/4	\$12.98	FBC 1/4 N1/4	\$37.53	MCC 1/4 N1/4	\$8.49	MEC 1/4 N1/4	\$14.61	RTC 1/4 N1/4	\$31.89
1/4"	NPT3/8"			FCC 1/4 N3/8	\$16.61	FBC 1/4 N3/8	\$59.96	MCC 1/4 N3/8	\$10.43	MEC 1/4 N3/8	\$21.82	RTC 1/4 N3/8	\$41.25
5/16"	NPT1/8"			FCC 5/16 N1/8	\$13.55			MCC 5/16 N1/8	\$9.95	MEC 5/16 N1/8	\$15.85	RTC 5/16 N1/8	\$33.80
5/16"	NPT1/4"			FCC 5/16 N1/4	\$14.30			MCC 5/16 N1/4	\$12.03	MEC 5/16 N1/4	\$16.44	RTC 5/16 N1/4	\$35.14
5/16"	NPT3/8"												
3/8"	NPT1/8"			FCC 3/8 N1/8	\$14.14			MCC 3/8 N1/8	\$11.00	MEC 3/8 N1/8	\$19.54		
3/8"	NPT1/4"	BTC 3/8 N1/4	\$33.99	FCC 3/8 N1/4	\$13.30	FBC 3/8 N1/4	\$38.58	MCC 3/8 N1/4	\$10.32	MEC 3/8 N1/4	\$18.13	RTC 3/8 N1/4	\$33.87
3/8"	NPT3/8"	BTC 3/8 N3/8	\$38.28	FCC 3/8 N3/8	\$17.92	FBC 3/8 N3/8	\$57.32	MCC 3/8 N3/8	\$12.28	MEC 3/8 N3/8	\$22.72	RTC 3/8 N3/8	\$39.23
3/8"	NPT1/2"			FCC 3/8 N1/2	\$23.74	FBC 3/8 N1/2	\$72.14	MCC 3/8 N1/2	\$14.10	MEC 3/8 N1/2	\$29.16	RTC 3/8 N1/2	\$60.60
1/2"	NPT1/4"			FCC 1/2 N1/4	\$18.75	FBC 1/2 N1/4	\$64.01	MCC 1/2 N1/4	\$15.83	MEC 1/2 N1/4	\$26.86		
1/2"	NPT3/8"	BTC 1/2 N3/8	\$50.84	FCC 1/2 N3/8	\$19.21	FBC 1/2 N3/8	\$53.81	MCC 1/2 N3/8	\$16.45	MEC 1/2 N3/8	\$26.86	RTC 1/2 N3/8	\$50.78
1/2"	NPT1/2"	BTC 1/2 N1/2	\$53.44	FCC 1/2 N1/2	\$25.79	FBC 1/2 N1/2	\$60.64	MCC 1/2 N1/2	\$17.60	MEC 1/2 N1/2	\$32.31	RTC 1/2 N1/2	\$53.44
1/2"	NPT3/4"			FCC 1/2 N3/4	\$32.12			MCC 1/2 N3/4	\$23.66	MEC 1/2 N3/4	\$47.28		
1/2"	NPT1"												
5/8"	NPT3/8"			FCC 5/8 N3/8	\$33.96			MCC 5/8 N3/8	\$22.37	MEC 5/8 N3/8	\$36.52		
5/8"	NPT1/2"	BTC 5/8 N1/2	\$66.23	FCC 5/8 N1/2	\$28.58	FBC 5/8 N1/2	\$79.60	MCC 5/8 N1/2	\$23.68	MEC 5/8 N1/2	\$38.45	RTC 5/8 N1/2	\$66.23
5/8"	NPT3/4"							MCC 5/8 N3/4	\$29.82	MEC 5/8 N3/4	\$48.92		
3/4"	NPT1/2"			FCC 3/4 N1/2	\$35.21			MCC 3/4 N1/2	\$31.01	MEC 3/4 N1/2	\$42.40		
3/4"	NPT3/4"	BTC 3/4 N3/4	\$79.93	FCC 3/4 N3/4	\$35.51	FBC 3/4 N3/4	\$103.84	MCC 3/4 N3/4	\$31.82	MEC 3/4 N3/4	\$46.14	RTC 3/4 N3/4	\$79.93
3/4"	NPT1"							MCC 3/4 N1	\$42.17				
1"	NPT1/2"												
1"	NPT3/4"			FCC 1 N3/4	\$72.31	FBC 1 N3/4	\$189.66	MCC 1 N3/4	\$52.97	MEC 1 N3/4	\$82.58		
1"	NPT1"			FCC 1 N1	\$86.22	FBC 1 N1	\$197.64	MCC 1 N1	\$49.18	MEC 1 N1	\$81.28		
4 mm	M5	BTC 4 M5		FCC 4 M5		FBC 4 M5		MCC 4 M5		MEC 4 M5		RTC 4 M5	
4mm	M6X1	BTC 4 M6		FCC 4 M6		FBC 4 M6		MCC 4 M6		MEC 4 M6		RTC 4 M6	
4 mm	R1/8	BTC 4 R1/8		FCC 4 R1/8		FBC 4 R1/8		MCC 4 R1/8		MEC 4 R1/8		RTC 4 R1/8	
4 mm	R1/4	BTC 4 R1/4		FCC 4 R1/4		FBC 4 R1/4		MCC 4 R1/4		MEC 4 R1/4		RTC 4 R1/4	
6mm	M5	BTC 6 M5		FCC 6 M5		FBC 6 M5		MCC 6 M5		MEC 6 M5		RTC 6 M5	
6mm	M6X1	BTC 6 M6		FCC 6 M6		FBC 6 M6		MCC 6 M6		MEC 6 M6		RTC 6 M6	
6mm	R1/8	BTC 6 R1/8		FCC 6 R1/8		FBC 6 R1/8		MCC 6 R1/8		MEC 6 R1/8		RTC 6 R1/8	
6mm	R1/4	BTC 6 R1/4		FCC 6 R1/4		FBC 6 R1/4		MCC 6 R1/4		MEC 6 R1/4		RTC 6 R1/4	
6mm	R3/8	BTC 6 R3/8		FCC 6 R3/8		FBC 6 R3/8		MCC 6 R3/8		MEC 6 R3/8		RTC 6 R3/8	
6mm	R1/2	BTC 6 R1/2		FCC 6 R1/2		FBC 6 R1/2		MCC 6 R1/2		MEC 6 R1/2		RTC 6 R1/2	
8mm	R1/8	BTC 8 R1/8		FCC 8 R1/8		FBC 8 R1/8		MCC 8 R1/8		MEC 8 R1/8		RTC 8 R1/8	
8 mm	R1/4	BTC 8 R1/4		FCC 8 R1/4		FBC 8 R1/4		MCC 8 R1/4		MEC 8 R1/4		RTC 8 R1/4	
8 mm	R3/8	BTC 8 R3/8		FCC 8 R3/8		FBC 8 R3/8		MCC 8 R3/8		MEC 8 R3/8		RTC 8 R3/8	
8mm	R1/2	BTC 8 R1/2		FCC 8 R1/2		FBC 8 R1/2		MCC 8 R1/2		MEC 8 R1/2		RTC 8 R1/2	
10mm	R1/8	BTC 10 R1/8		FCC 10 R1/8		FBC 10 R1/8		MCC 10 R1/8		MEC 10 R1/8		RTC 10 R1/8	
10mm	R1/4	BTC 10 R1/4		FCC 10 R1/4		FBC 10 R1/4		MCC 10 R1/4		MEC 10 R1/4		RTC 10 R1/4	
10mm	R3/8	BTC 10 R3/8		FCC 10 R3/8		FBC 10 R3/8		MCC 10 R3/8		MEC 10 R3/8		RTC 10 R3/8	
10mm	R1/2	BTC 10 R1/2		FCC 10 R1/2		FBC 10 R1/2		MCC 10 R1/2		MEC 10 R1/2		RTC 10 R1/2	
12mm	R1/4	BTC 12 R1/4		FCC 12 R1/4		FBC 12 R1/4		MCC 12 R1/4		MEC 12 R1/4		RTC 12 R1/4	
12mm	R3/8	BTC 12 R3/8		FCC 12 R3/8		FBC 12 R3/8		MCC 12 R3/8		MEC 12 R3/8		RTC 12 R3/8	
12mm	R1/2	BTC 12 R1/2		FCC 12 R1/2		FBC 12 R1/2		MCC 12 R1/2		MEC12 R1/2		RTC 12 R1/2	

Manual & Solenoid Process Valves



	<p>Fine Quality</p> <p>Precision Engineered</p> <p>Advanced Design</p> <p>Excellent Prices</p>			



Contents

STC Solenoid & Manual Valve Numbering System.....	E2-3
STC Solenoid Valve Specifications.....	E3
STC Process Valve List Price.....	E4-7
STC Process Valve Dimensions.....	E8-9
STC Valve Technical Data.....	E10-11
STC Solenoid Valve Internal Components.....	E12

STC Process Solenoid Valve Numbering System

Ordering Part No. =
eg. 2W025-1/4-1

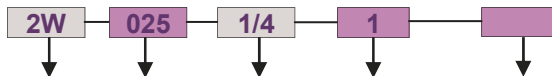

ACTION	NC/NO	Body Material	Orifice Size 10X (mm)	Port Size NPT	Voltage Options	Seal Options	Pressure (PSI)	Cv	Features									
2 Way Direct Acting Zero Differential	NC	Stainless	2H	012	1/8	1 = 12 VDC 2 = 24 VDC 2A = 24 VAC 3 = 110 VAC 4 = 220VAC (50/60Hz) E = Explosion Proof	Blank: PTFE (standard)	0 to 1000	0.05	Operating Temp: -5 to 80 °C Operating Pressure: 2P/2V: Vacuum to 115 PSI 2S/2W: Vacuum to 150 PSI Coil: F Class, IP65, 100% ED Seals: NBR, (Viton Option) Service: Air, Gas, Liquid Wetted Parts: 2P: Plastic & Stainless Steel 2V: Aluminum & Stainless Steel 2S: Stainless Steel 2W: Brass & Stainless Steel								
		Plastic	2P	025	1/8		Vacuum to 115	0.23										
		Aluminum	2V		1/4		Vacuum to 115	0.23										
		PTFE (Teflon)	2T	060	1/4		Vacuum to 22	2.8										
		Stainless	2S		3/8		Vacuum to 22	2.8										
				1/2	Vacuum to 22		2.8											
	NO	Stainless	2SO	025	1/4		Vacuum to 150	0.23										
				035	1/4		Vacuum to 150	0.5										
		040	3/8	Vacuum to 150	0.6													
		050	3/8	Vacuum to 80	1.0													
		Brass	2W	025	1/4		Vacuum to 150	0.23										
		035	1/4	Vacuum to 150	0.5													
040	3/8	Vacuum to 150	0.6															
3 Way Direct Acting Zero Differential	NC/NO	Stainless	2SO	040	3/8	Vacuum to 100	0.6											
		Brass	2WO	010	1/8	Vacuum to 100	0.6											
		Plastic	3P		010	1/8	Vacuum to 100	0.05										
		Aluminum	3V	025	1/4	Vacuum to 20	0.23											
		Stainless	3S	020	1/4	Vacuum to 100	0.15											
				035	1/4	Vacuum to 60	0.5											
2 Way Direct Lift Diaphragm Zero Differential	NC	Stainless Steel	2S	160	3/8	1 = 12 VDC 2 = 24 VDC 2A = 24 VAC 3 = 110 VAC 4 = 220VAC (50/60Hz) E = Explosion Proof	Blank: NBR (standard)	0 to 145	4.8	Operating Temp: -5 to 80 °C Operating Pressure: Vacuum to 150 PSI Coil: H Class, IP65, 100% ED Seals: NBR, (Viton Option) Service: Air, Gas, Liquid Wetted Parts: 2S/2SO: Stainless Steel 2W/2WO: Brass & Stainless Steel								
				160	1/2		0 to 145	4.8										
				200	3/4		0 to 145	7.6										
				250	1		0 to 145	12										
				350	1 1/4		0 to 145	24										
				400	1 1/2		0 to 145	29										
	NO	Stainless Steel	2SO	160	3/8		0 to 145	4.8										
				160	1/2		0 to 145	4.8										
				200	3/4		0 to 145	7.6										
				250	1		0 to 145	12										
				350	1 1/4		0 to 145	24										
				400	1 1/2		0 to 145	29										
Brass	2WO	160	3/8	0 to 145	4.8													
		160	1/2	0 to 145	4.8													
		200	3/4	0 to 145	7.6													
		250	1	0 to 145	12													
		350	1 1/4	0 to 145	24													
		400	1 1/2	0 to 145	29													
2 Way Direct Lift Piston Zero Differential	NC	Stainless Steel	2LS	120	3/8	1 = 12 VDC 2 = 24 VDC 2A = 24 VAC 3 = 110 VAC 4 = 220VAC (50/60Hz) E = Explosion Proof	Blank: PTFE (standard)	0 to 145	12	Operating Temp: -20 to 180 °C Operating Pressure: 0 to 232 PSI Coil: H Class, IP65, 100% ED Seals: NBR, (Viton Option) Service: Air, Gas, Liquid Wetted Parts: 2S/2SO: Stainless Steel 2W/2WO: Brass & Stainless Steel								
				150	1/2		0 to 145	4.8										
				200	3/4		0 to 145	8.5										
				250	1		0 to 145	14										
				320	1 1/4		0 to 145	20										
				400	1 1/2		0 to 145	31										
2 Way Pilot Diaphragm	NC	Brass	2V	130	3/8		1 = 12 VDC 2 = 24 VDC 2A = 24 VAC 3 = 110 VAC 4 = 220VAC (50/60Hz) E = Explosion Proof	Blank: NBR (standard)	0 to 145		6.2	Operating Temp: -5 to 80 °C Operating Pressure: 4 to 115 PSI Coil: H Class, IP65, 100% ED Seal: NBR Service: Air, Gas, Liquid Wetted Parts: Brass						
				130	1/2			0 to 145	6.2									
				250	3/4			0 to 145	23									
				250	1			0 to 145	23									
				2 Way Pilot Piston	NC			Brass	2L		170		3/8	1 = 12 VDC 2 = 24 VDC 2A = 24 VAC 3 = 110 VAC 4 = 220VAC (50/60Hz) E = Explosion Proof	Blank: PTFE (standard)	0 to 145	4.8	Operating Temp: -5 to 180 °C Operating Pressure: 7 to 230 PSI Coil: H Class, IP65, 100% ED Seals: PTFE (Teflon) Service: Steam, Air, Liquid Wetted Parts: 2L: Brass & Stainless Steel, PTFE
											170		1/2		0 to 145	4.8		
170	3/4	0 to 145	4.8															
200	1	0 to 145	12															
300	1 1/2	0 to 145	12															
2 Way Pilot Piston 7 PSI Differential	NC	Brass	2M	120	3/8	1 = 12 VDC 2 = 24 VDC 2A = 24 VAC 3 = 110 VAC 4 = 220VAC (50/60Hz) E = Explosion Proof		Blank: PTFE Standard	0 to 145	4.5	Operating Temp: -20 to 180°C Operating Pressure: 7 to 230 PSI Coil: H Class, IP65, 100% ED Seal: PTFE Service: Air, Gas, Liquid, Steam Wetted Parts: stainless Steel							
				150	1/2				0 to 145	4.5								
				200	3/4				0 to 145	9.3								
				250	1		0 to 145		12									
	NO	Stainless Steel	2MS	320	1 1/4		0 to 145		24									
				400	1 1/2		0 to 145		29									
				2MSO	500		2		0 to 145	48								

STC Manual Valve Numbering System

Ordering Part No. =
(eg. V1-1/4)

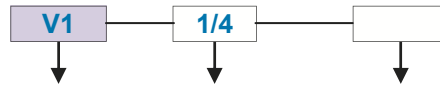

Manual Ball Valves	Model	Port Size (NPT)	Options
Reduced port 316 SS ball valve (1 Piece)	V1	1/4	L = Lockable Handle P = Panel Mount
Full port 316 SS ball valve (2 Piece)	V2	3/8	
Full port 316 SS ball valve (3 Piece)	V3	1/2	
Full port 316 SS ball valve (3 Piece, Tri-Clamp)	V3C	3/4	
Full port brass ball valve (2 Piece)	T101L	1	
Reduced port chrome plated brass ball valve (FXF port)	T400	1 1/4	
Reduced port chrome plated brass ball valve (FXM port)	T400FM	1 1/2	
316 SS Needle valve	VNO1	2	

STC Solenoid Numbering System

Ordering Part No. =
(eg. 2W200C-1)

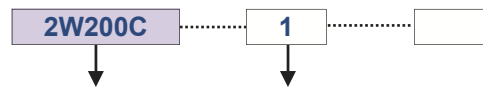

Coils	Model	Voltage	Wattage, W
Coil for 2P025 & 2V Series Valves	200C	1 = 12 VDC 2 = 24 VDC 2A = 24 VAC 3 = 110 VAC 4 = 220VAC (50-60Hz)	3, 4.8, 6.5
Coil for 2S/2W025-250, 3S/2W020-035 series valves	2W200C		14, 20
Coil for 2LS120-200, 2MS/2MSO120-500, 2P/2PO160-250, 2S/2W350-500, 2WO/2SO160-250 series valves	2WO250C		20-30
Coil for 2L170-300, 2LS250-500, 2WO/2SO350-500 series valves	2W350C		25-35

Solenoid Valve Specifications

Valve Model	2H012-032	2H080-250		2L	2LS		2MS	2MSO		2P025	3P010-025
Valve Type	2 Way	2 Way		2 Way	2 Way		2 Way	2 Way		2 Way	3 Way
Normally Closed (NC)	NC	NC		NC	NC		NC	NO		NC	NC
Normally Open (NO)	Direct Acting	Pilot Piston		Pilot Piston	Direct Lift Piston		Pilot Piston	Pilot Piston		Direct Acting	Direct Acting
Operating Pressure (PSI)	0 to 1000	45 to 725		7 to 232	0 to 150		7 to 230	7 to 230		0 to 115	0 up to 115
Operating Temperature (°C)	-20 to 85°C	-20 to 90°C		-20 to 180°C	-20 to 180°C		-20 to 180°C	-20 to 180°C		-5 to 80°C	-5 to 80°C
Ambient Temperature (°C)	-20 to 55°C	-20 to 55°C		-20 to 55°C	-20 to 55°C		-20 to 55°C	-20 to 55°C			
Port Size (NPT)	1/8	3/8 to 1		3/8 to 2	3/8 to 2		3/8 to 2	3/8 to 2		1/8 to 1/4	1/8 to 1/4
Body Materials	Stainless Steel	Brass		Brass	Stainless Steel		Stainless Steel	Stainless Steel		Engineered Plastic	Engineered Plastic
Seal Materials	PTFE/Teflon	PTFE/Teflon		PTFE/Teflon	PTFE/Teflon		PTFE/Teflon	PTFE/Teflon		NBR	NBR
Coil Protection Insulation Class	H Class IP65	H Class IP65		H Class IP65	H Class IP65		H Class IP65	H Class IP65		B Class IP65	B Class IP65
Coil Duty	100% ED	100% ED		100% ED	100% ED		100% ED	100% ED		100% ED	100% ED
Coil Power	14W	8 W, 14VA		30-35W	30-35 W		15 W, 22VA	15 W, 22VA		6.5W	6.5W
Electrical Connections	Conduit	DIN		DIN	DIN		DIN	DIN		DIN	DIN
Service	Air, Liquid			Air, Liquid, Steam			Air, Liquid, Steam			Air, Liquid, Vacuum	

Valve Model	2S025-050	2S160-500	2SO160-500	2T	2V025	2V130-250	2W025-040	2W160-500	2WO160-500	3S010-050	3W010-050
Valve Type	2 Way	2 Way	2 Way	2 Way	2 Way	2 Way	2 Way	2 Way	2 Way	3 Way	3 Way
Normally Closed (NC)	NC	NC	NO	NC	NC	NC	NC	NC	NO	NC	NC
Normally Open (NO)	Direct Acting	Direct Lift Diaphragm	Direct Lift Diaphragm	Direct Lift Diaphragm	Direct Acting	Pilot Diaphragm	Direct Acting	Direct Lift Diaphragm	Direct Lift Diaphragm	Direct Acting	Direct Acting
Operating Pressure (PSI)	0 up to 150	0 to 150	0 to 120	0 to 22	0 to 115	4 to 115	0 to 150	0 to 150	0 to 150	0 to 100	0 to 100
Operating Temperature (°C)	-5 to 80°C	-5 to 80°C	-5 to 80°C	-20 to 80°C	-5 to 80°C	-5 to 80°C	-10 to 80°C	-10 to 80°C	-10 to 80°C	-10 to 80°C	-10 to 80°C
Ambient Temperature (°C)	-20 to 55°C	-20 to 55°C	-20 to 55°C	-20 to 55°C			-20 to 55°C	-20 to 55°C	-20 to 55°C	-20 to 55°C	-20 to 55°C
Port Size (NPT)	1/4 to 3/8	3/8 to 2	3/8 to 2	1/4 to 1/2	1/8 to 1/4	3/8 to 1	1/4 to 3/8	3/8 to 2	3/8 to 2	1/8 to 1/4	1/8 to 1/4
Body Materials	Stainless Steel	Stainless Steel	Stainless Steel	Teflon	Aluminum	Brass	Brass	Brass	Brass	Stainless Steel	Brass
Seal Materials: NBR (Options: EPDM, Viton)	NBR	NBR	NBR	Viton/EPDM	NBR	NBR/Viton	NBR	NBR	NBR	NBR	NBR
Coil Protection Insulation Class	H Class IP65	H Class IP65	H Class IP65	H Class IP65	B Class IP65	B Class IP65	H Class IP65	H Class IP65	H Class IP65	H Class IP65	H Class IP65
Coil Duty	100% ED	100% ED	100% ED	100% ED	100% ED	100% ED	100% ED	100% ED	100% ED	100% ED	100% ED
Coil Power	14-20W	20-35W	30W	20W	6.5W	6.5W	14 to 20W	20-35W	30W	14-20W	14-20W
Electrical Connections	DIN	DIN	DIN	DIN	DIN	DIN	DIN	DIN	DIN	DIN	DIN
Service	Air, Gas, Liquid, Vacuum			Air, Liquid	Air, Vacuum	Air, Liquid	Air, Gas, Liquid, Vacuum				

Process Solenoid Valve List Price

To Order, Please Specify: 1. Model No., 2. Voltage									
Direct Acting	Valve Type	Part No.	List Price	Port Size (NPT)	Voltage Options	Power (W)	Cv	Features	
	2 Way, NC Direct Acting Plastic Body	2P025-1/8S	\$23.43	1/8	1 = 12 VDC 2 = 24VDC	3-6.5	0.23	2 Way, Direct Acting, Normally Closed Operating Temp: -5 to 80 °C Operating Pressure: Vacuum to 115 PSI Coil: F Class, IP65, 100% ED Service: Air, Liquid Seals: NBR Wetted Surfaces: 2P025: Nylon & Stainless Steel (for DI water) 2V025: Anodized Aluminum, Brass & Stainless Steel	
		2P025-1/4S	\$21.23	1/4			0.23		
	2 Way, NC Direct Acting Aluminum Body	2V025-1/8	\$21.67	1/8	2A=24VAC 3 = 110VAC 4 = 220VAC (50/60Hz)	3-6.5	0.23		
		2V025-1/4	\$21.67	1/4			0.23		
	2 Way, NC Direct Acting Stainless Steel Body	2S025-1/8H	\$32.70	1/8	1 = 12 VDC 2 = 24VDC 2A=24VAC 3 = 110VAC 4 = 220VAC (50/60Hz)	10-14	0.23	2 Way, Direct Acting, Normally Closed Operating Temp: -5 to 80 °C Operating Pressure: Vacuum to 150 PSI Coil: H Class, IP65, 100% ED Service: Air, Gas, Liquid Seals: NBR Body Material: 2S Series: 304 Stainless Steel Hex Shape Body 2W Series: Brass Hex Shape Body	
		2S025-1/4H	\$32.70	1/4			0.23		
	2 Way, NC Direct Acting Brass Body	2W025-1/8H	\$30.50	1/8			0.23		
		2W025-1/4H	\$30.50	1/4			0.23		
	2 Way, NC Direct Acting Brass Body	2W035-1/4	\$36.07	1/4	1 = 12 VDC 2 = 24VDC 2A=24VAC 3 = 110VAC 4 = 220VAC (50/60Hz)	10-14	0.5		
		2W040-3/8	\$39.35	3/8			0.60		
	2 Way, NC Direct Acting Stainless Steel Body	2S025-1/4	\$35.35	1/4	1 = 12 VDC 2 = 24VDC 2A=24VAC 3 = 110VAC 4 = 220VAC (50/60Hz)	14-20	0.23		2 Way, Direct Acting, Normally Closed Operating Temp: -5 to 80 °C Coil: H Class, IP65, 100% ED Service: Air, Gas, Liquid Seals: NBR, (Options: Viton, EPDM) Body Material: 304 Stainless Steel Body Operating Pressure: 2S025: Vacuum to 200 PSI 2S035: Vacuum to 150 PSI 2S040: Vacuum to 150 PSI 2S050: Vacuum to 80 PSI
		2S035-1/4	\$38.64	1/4			0.5		
		2S040-3/8	\$49.05	3/8			0.6		
		2S050-1/4	\$49.05	1/4			1.0		
		2S050-3/8	\$49.05	3/8			1.0		
	2 Way, NC Direct Acting Stainless Steel	2H012	\$64.80	1/8	1 = 12 VDC 2 = 24VDC 2A=24VAC 3 = 110VAC 4 = 220VAC (50/60Hz)	14-20	0.05		
		2H016	\$64.80	1/8			.085		
	2 Way, NO Direct Acting Stainless Steel	2SO025-1/44	\$62.73	1/4	1 = 12 VDC 2 = 24VDC 2A=24VAC 3 = 110VAC 4 = 220VAC (50/60Hz)	30	0.6	2 Way, Direct Acting, Normally Open Operating Temp: -5 to 80 °C Operating Pressure: Vacuum to 90 PSI Coil: H Class, IP65, 100% ED Service: Air, Gas, Liquid Seals: NBR, (Viton Option) Body Material: 2S Series: 304 Stainless Steel Body 2W Series: Brass	
		2SO040-3/8	\$73.51	3/8			0.6		
	2 Way, NO Direct Acting Brass	2WO025-1/4	\$56.22	1/4	1 = 12 VDC 2 = 24VDC 2A=24VAC 3 = 110VAC 4 = 220VAC (50/60Hz)	30	0.6		
		2WO040-3/8	\$65.44	3/8			0.6		
	3 Way, NC Direct Acting Aluminum	3V010-1/8	\$22.81	1/8	1 = 12 VDC 2 = 24VDC 2A=24VAC 3 = 110VAC 4 = 220VAC (50/60Hz)	3-6.5	0.05	3 Way, Direct Acting Operating Temp: -5 to 80 °C Pressure: Vacuum to 115 PSI Coil: F Class, IP65, 100% ED Service: Air, Liquid Seals: NBR Body Material: Anodized Aluminum	
		3V010-1/4	\$22.81	1/4			0.05		
	3 Way, NC Direct Acting Stainless Steel	3S020-1/4	\$67.98	1/4	1 = 12 VDC 2 = 24VDC 2A=24VAC 3 = 110VAC 4 = 220VAC (50/60Hz)	14-20	0.2	3 Way, Direct Acting Operating Temp: -5 to 80 °C Pressure: 3S020 Vacuum to 100 PSI, 3S035 Vacuum to 60 PSI, Coil: H Class, IP65, 100% ED Service: Air, Liquid Seal: Viton Body Material: Stainless Steel	
		3S035-1/4	\$67.98	1/4			0.35		

Process Solenoid Valve List Price



To Order, Please Specify: 1. Model No., 2. Voltage								
		Part No.	List Price	Port Size (NPT)	Voltage Options	Power (W)	Cv	Features
	2 Way, NC Direct Lift Diaphragm Brass Zero Differential	2W160-3/8	\$68.91	3/8	Voltage Options: 1 = 12 VDC 2 = 24VDC 2A=24VAC 3 = 110VAC 4 = 220VAC (50/60Hz)	14-20	4.8	Normally Closed, 2 Way Direct Lift Diaphragm Operating Temp: -5 to 80 °C (with NBR Seal) -5 to 120 °C (with Viton Seal) Operating Pressure: Vacuum to 150 PSI (AC Coil) Vacuum to 100 PSI (DC Coil) Coil: H Class, IP65, 100% ED Service: Air, Gas, Liquid Seals: NBR, (Option: Viton, EPDM) Body Material: Brass
		2W160-1/2	\$73.85	1/2			4.8	
		2W200-3/4	\$79.88	3/4			7.6	
		2W250-1	\$101.64	1			12	
		2W350-1 1/4	\$195.04	1 1/4			24	
		2W400-1 1/2	\$224.45	1 1/2			29	
2W500-2	\$314.81	2	48					
	2 Way, NC Direct Lift Diaphragm Stainless Steel Zero Differential	2S160-3/8	\$119.19	3/8	Voltage Options: 1 = 12 VDC 2 = 24VDC 2A=24VAC 3 = 110VAC 4 = 220VAC (50/60Hz)	14-20	4.8	Normally Closed, 2 Way Direct Lift Diaphragm Operating Temp: -5 to 80 °C (with NBR Seal) -5 to 120 °C (with Viton Seal) Operating Pressure: Vacuum to 150 PSI (AC Coil) Vacuum to 100 PSI (DC Coil) Coil: H Class, IP65, 100% ED Service: Air, Gas, Liquid Seals: NBR, (Option: Viton, EPDM) Body Material: 304 Stainless Steel
		2S160-1/2	\$119.19	1/2			4.8	
		2S200-3/4	\$135.17	3/4			7.6	
		2S250-1	\$151.92	1			12	
		2S350-1 1/4	\$276.19	1 1/4			24	
		2S400-1 1/2	\$294.66	1 1/2			29	
2S500-2	\$460.34	2	48					
	2 Way, NC Direct Lift Diaphragm Plastic Zero Differential	2P160-1/2	\$51.21	1/2	Voltage Options: 1 = 12 VDC 2 = 24VDC 2A=24VAC 3 = 110VAC 4 = 220VAC (50/60Hz)	20-30	4.8	Normally Closed, 2 Way Direct Lift Diaphragm Operating Temp: 0 to 50 °C Operating Pressure: Vacuum to 90 PSI Coil: H Class, IP65, 100% ED Service: Air, Liquid Seals: NBR, (Option: Viton, EPDM) Body Material: Nylon Plastic
		2P200-3/4	\$60.91	3/4			4.8	
		2P250-1	\$83.54	1			7.6	
	2 Way, NO Direct Lift Diaphragm Zero Differential Brass	2WO 160-3/8	\$105.51	3/8	Voltage Options: 1 = 12 VDC 2 = 24VDC 2A=24VAC 3 = 110VAC 4 = 220VAC (50/60Hz)	30	4.8	Normally Open 2 Way, Direct Lift Diaphragm Operating Temp: -5 to 80 °C (with NBR Seal) -5 to 120 °C (with Viton Seal) Pressure: Vacuum to 90 PSI Coil: H Class, IP65, 100% ED Service: Air, Liquid Seals: NBR (Option: Viton, EPDM) Body Material: Brass
		2WO 160-1/2	\$105.51	1/2			4.8	
		2WO 200-3/4	\$115.06	3/4			7.6	
		2WO 250-1	\$134.28	1			12	
		2WO 350-1 1/4	\$236.18	1 1/4			24	
		2WO 400-1 1/2	\$282.63	1 1/2			29	
2WO 500-2	\$382.37	2	48					
	2 Way, NO Direct Lift Diaphragm Zero Differential Stainless Steel	2SO 160-3/8	\$137.10	3/8	Voltage Options: 1 = 12 VDC 2 = 24VDC 2A=24VAC 3 = 110VAC 4 = 220VAC (50/60Hz)	30	4.8	Normally Open 2 Way, Direct Lift Diaphragm Operating Temp: -5 to 80 °C (with NBR Seal) -5 to 120 °C (with Viton Seal) Pressure: Vacuum to 90 PSI Coil: H Class, IP65, 100% ED Service: Air, Liquid Seals: NBR (Option: Viton, EPDM) Body Material: Stainless Steel
		2SO 160-1/2	\$149.59	1/2			4.8	
		2SO 200-3/4	\$174.56	3/8			7.6	
		2SO 250-1	\$274.21	1			12	
		2SO 350-1 1/4	\$326.98	1 1/4			24	
		2SO 400-1 1/2	\$380.20	1 1/2			29	
2SO 500-2	\$518.46	2	48					
	2 Way, NC Pilot Piston Plastic	2PO160-1/2	\$74.25	1/2	Voltage Options: 1 = 12 VDC 2 = 24VDC 2A=24VAC 3 = 110VAC 4 = 220VAC (50/60Hz)	30-35	4.8	Normally Open 2 Way, Direct Lift Diaphragm Temperature: 0 to 50°C Pressure: Vacuum to 90 PSI Coil: H Class, IP65, 100% ED Service: Air, Liquid, Vacuum Seals: NBR Body Material: Nylon Plastic
		2PO200-3/4	\$83.96	3/4			4.8	
		2PO250-1	\$106.58	1			4.8	
	2 Way, NC Pilot Piston Brass	2L170-3/8	\$149.62	3/8	Voltage Options: 1 = 12 VDC 2 = 24VDC 2A=24VAC 3 = 110VAC 4 = 220VAC (50/60Hz)	30-35	4.8	Normally Closed, 2 Way, Pilot Lift Piston Brass Body, Seals: PTFE Operating Temp: -5 to 180 °C Operating Pressure: 7 to 232 PSI Coil: F Class, IP65, 100% ED Service: Air, Liquid, Steam Installation: Vertical Coil Position, Horizontal Flow
		2L170-1/2	\$149.62	1/2			4.8	
		2L170-3/4	\$157.94	3/4			4.8	
		2L200-1	\$184.06	1			12	
		2L300-1 1/4	\$213.74	1 1/4			20	
		2L300-1 1/2	\$327.50	1 1/2			20	
2L500-2	N/A	2	48					
	2 Way, NC Direct Lift Piston Zero Differential Stainless Steel	2LS120 - 3/8	\$147.47	3/8	Voltage Options: 1 = 12 VDC 2 = 24VDC 2A=24VAC 3 = 110VAC 4 = 220VAC (50/60Hz)	15W	4.5	Normally Closed, 2 Way, Direct Lift Piston Operation Operating Pressure: 0 to 150 PSI Fluid Temperature: -20°C to 180°C Seal: PTFE Compatible Fluid: Steam, Air, Inert Gases, Water, Liquid, etc. Body Material: Stainless Steel
		2LS150 - 1/2	\$174.56	1/2			4.5	
		2LS200 - 3/4	\$215.50	3/4			9.3	
		2LS250 - 1	\$269.32	1			12	
		2LS320 - 1 1/4	\$353.50	1 1/4			24	
		2LS400 - 1 1/2	\$391.37	1 1/2			29	
2LS500 - 2	\$565.25	2	48					

	Valve Type	Part No.	List Price	Port Size (NPT)	Voltage	Power (W)	Cv (Orifice)	Features	
	2 Way, NC Pilot Piston Stainless Steel	2MS120 - 3/8	\$159.59	3/8	Voltage Options: 1 = 12 VDC 2 = 24VDC 2A=24VAC 3 = 110VAC 4 = 220VAC (50/60Hz)	15-30W	4.5	Normally Closed, 2 Way, Pilot Piston Operation Operating Pressure: Standard: 6 to 230 PSI Options: Medium: 6 to 580 PSI (DC Power) Medium: 6 to 725 PSI (AC Power) High: 87 to 1160 PSI Fluid Temperature: -4°C to 356°F (-20°C to 180°C) Seal: PTFE (Option: Viton) Service: Steam, Air, Inert Gases, Water, Liquid, etc.	
		2MS150 - 1/2	\$159.59	1/2			4.5		
		2MS200 - 3/4	\$191.18	3/4			9.3		
		2MS250 - 1	\$244.39	1			12		
		2MS320 - 1 1/4	\$345.80	1 1/4			24		
		2MS400 - 1 1/2	\$363.25	1 1/2			29		
	2MS500 - 2	\$563.59	2	48					
	2 Way, NO Pilot Piston Stainless Steel	2MSO120 - 3/8	\$195.34	3/8	Voltage Options: 1 = 12 VDC 2 = 24VDC 2A=24VAC 3 = 110VAC 4 = 220VAC (50/60Hz)	15-30W	4.5		Normally Open, 2 Way, Pilot Piston Operation Operating Pressure: 6 to 145 PSI Fluid Temperature: -4°C to 356°F (-20°C to 180°C) Seal: PTFE Ambient Temperature: -20 to 55°C Compatible Fluid: Steam, Air, Inert Gases, Water, Liquid, etc.
		2MSO150 - 1/2	\$195.34	1/2			4.5		
		2MSO200 - 3/4	\$226.93	3/4			9.3		
		2MSO250 - 1	\$280.13	1			12		
		2MSO320 - 1 1/4	\$381.55	1 1/4			24		
2MSO400 - 1 1/2		\$399.00	1 1/2	29					
2MSO500 - 2	\$599.33	2	48						
	2 Way, NC Pilot Diaphragm Brass	2V130-3/8	\$67.75	3/8	Voltage Options: 1 = 12 VDC 2 = 24VDC 2A=24VAC 3 = 110VAC 4 = 220VAC (50/60Hz)	3 to 6.5 W	6.2 (13MM)	Normally Closed, 2 Way, Pilot Operated Diaphragm Brass Body, Seals: NBR Operating Temp -5 to 80°C Operating Pressure: 4 to 115 PSI (Option: 4-200PSI) Coil: F Class, IP65, 100% ED Service: Air, Gas, Water, Liquid	
		2V130-1/2	\$67.75	1/2			6.2 (13MM)		
		2V250-3/4	\$130.65	3/4			23 (25MM)		
		2V250-1	\$130.65	1			23 (25MM)		
	Coil Options	200C-U	\$13.68	UL					
		200C-E	\$98.85	Explosion Proof					
	2 Way, NC High Pressure Valves Stainless Steel	2E100-3/8	\$443.56	3/8	Voltage Options: 1 = 12 VDC 2 = 24VDC 2A=24VAC 3 = 110VAC 4 = 220VAC (50/60Hz)	20-25W	(10MM)	Normally Closed, 2 Way, Pilot Piston Operating Pressure: 87 to 1450PSI (Option: 87-2320 PSI) Fluid Temperature: -40°C to 180°C Seal: PTFE (Teflon) Service: Steam, Air, Inert Gases, Water, Liquid	
		2E150-1/2	\$553.01	1/2			(15MM)		
		2E200-3/4	\$664.77	3/4			(20MM)		
		2E250-1	\$735.05	1			(25MM)		
	2 Way, NC High Pressure Valves Brass	2H080	\$185.01	1/4	Voltage Options: 1 = 12 VDC 2 = 24VDC 2A=24VAC 3 = 110VAC 4 = 220VAC (50/60Hz)	8-14W	(8MM)	Normally Closed, 2 Way, Pilot Piston Operating Pressure: 45 to 725 PSI Fluid Temperature: -20 to 90°C Seal: PTFE (Teflon) Coil: 8W (DC), 14VA (AC) Service: Air, Inert Gases, Water, Liquid	
		2H100	\$200.47	3/8			(10MM)		
		2H130	\$211.45	1/2			(13MM)		
		2H200	\$307.53	3/4			(20MM)		
		2H250	\$441.27	1			(25MM)		
	Teflon Diaphragm Isolated Teflon Direct Acting Solenoid Valve	2T060 - 1/4	\$294.94	1/4	Voltage Options: 1 = 12 VDC 2 = 24VDC 2A=24VAC 3 = 110VAC 4 = 220VAC (50/60Hz)	20-30W	(6MM)	Normally Closed, 2 Way, Teflon Isolated Diaphragm, Direct Acting Fluid Temperature: 0°C to 80°C Seal: Viton, Option: EPDM Operating Pressure: 0 to 22 PSI Service: Air, Inert Gases, Water, Liquid	
		2T060 - 3/8	\$294.94	3/8			(6MM)		
		2T060 - 1/2	\$294.94	1/2			(6MM)		
	2 Way, NC Pilot Diaphragm Stainless Steel Valve	2DS500-2F	\$679.25	2" Flange	Voltage Options: 1 = 12 VDC 2 = 24VDC 2A=24VAC 3 = 110VAC 4 = 220VAC (50/60Hz)	12-14W 26VA	35 (50MM)	Normally Closed, 2 Way, Pilot Diaphragm Flange Connection Operating Pressure: 4 to 175 PSI (Option: 4 to 230 psi) Fluid Temperature: -5 to 80°C Seal: NBR (Options: Viton, EPDM) Coil: 12-14W (DC), 26VA (AC) Service: Air, Inert Gases, Water, Liquid	
		2DS650-2 1/2F	\$1,436.88	2 1/2" Flange			52.5 (65MM)		
		2DS800-3F	\$1,654.59	3" Flange			81.7 (80MM)		
		2DS1000-4F	\$2,473.17	4" Flange			128.4 (100MM)		
		2DS1250-5F		5" Flange			221.7 (125MM)		
		2DS1500-6F		6" Flange			291.7 (150MM)		
		2DS2000-8F		8" Flange			513.5 (200MM)		
	2 Way, NO Pilot Diaphragm Stainless Steel Valve	2DSO500-2F		2" Flange	Voltage Options: 1 = 12 VDC 2 = 24VDC 2A=24VAC 3 = 110VAC 4 = 220VAC (50/60Hz)	12-14W 26VA	35 (50MM)	Normally Open, 2 Way, Pilot Diaphragm Flange Connection Operating Pressure: 4 to 115 PSI Fluid Temperature: -5 to 80°C Seal: NBR (Options: Viton, EPDM) Coil: 12-14W (DC), 26VA (AC) Service: Air, Inert Gases, Water, Liquid	
		2DSO650-2 1/2F		2 1/2" Flange			52.5 (65MM)		
		2DSO800-3F	\$1,579.36	3" Flange			81.7 (80MM)		
		2DSO1000-4F		4" Flange			128.4 (100MM)		
		2DSO1250-5F		5" Flange			221.7 (125MM)		
		2DSO1500-6F		6" Flange			291.7 (150MM)		
		2DSO2000-8F		8" Flange			513.5 (200MM)		



	Part No.	List Price	Voltage Options	Electrical Connection	Power	Applications
	2W200C	\$26.62		H Class Insulation, IP65 Duty Cycle: 100% ED	12 to 20W	For 2S/2W 025 to 250 series valves
	2W350C	\$41.19	1 = 12 VDC 2 = 24VDC		25-35W	For 2SO/2WO 160-500 series valves
	2WO250C	\$41.19	2A=24VAC 3 = 110VAC 4 = 220VAC (AC 50/60Hz)		20-30 W	For 2SO/2WO 160-500 series valves
	200C	\$9.13		D = DIN (with LED indicator) G = Grommet (12" Lead Wire) F Class Insulation, IP65	3 to 6.5 W	For 2V & 2P025-035 & 2V1, 3V1 series valves
	2W250C-DIN-1/2M	\$6.31	20" Long Cable	Molded Cable with DIN 43650 Form A Plug		
	2W250C-DIN-1M	\$7.49	40" Long Cable			

STC Manual Valve List Price

										
	Reduced Port Ball Valves		Full Port Ball Valves		Full Port Ball Valves		Full Port Ball Valves		Needle Valves	
Model	V1		V2		V3		V3C		VNO1	
Material	316 SS		316 SS		316 SS		316 SS		316 Stainless Steel	
Port	FNPT		FNPT		FNPT		Clamp		FNPT	
Size 1/4"	V1-1/4	\$10.98	V2-1/4	\$21.16	V3-1/4	\$25.61			VNO1-1/4	\$40.82
3/8"	V1-3/8	\$10.98	V2-3/8	\$21.16	V3-3/8	\$25.61			VNO1-3/8	\$40.82
1/2"	V1-1/2	\$12.13	V2-1/2	\$27.02	V3-1/2	\$30.34			VNO1-1/2	\$46.52
3/4"	V1-3/4	\$17.65	V2-3/4	\$31.58	V3-3/4	\$38.63			VNO1-3/4	\$65.68
1"	V1-1	\$22.78	V2-1	\$47.31	V3-1	\$52.16	V3C-1	\$61.15	VNO1-1	\$89.00
1 1/4"	V1-1 1/4	\$33.49	V2-1 1/4	\$69.90	V3-1 1/4	\$79.16				
1 1/2"	V1-1 1/2	\$45.74	V2-1 1/2	\$99.86	V3-1 1/2	\$109.45	V3C-1 1/2	\$118.63		
2"	V1-2	\$65.65	V2-2	\$121.59	V3-2	\$147.63	V3C-2	\$166.26		
3"					V3-3	\$639.44	V3C-3	\$376.94		

								
	Miniature Ball Valves		Miniature Ball Valves		L Port 3 Way Ball Valve UL Listed Ball Valves		T Port 3 Way Ball Valve UL Listed Ball Valves	
Model	T400		T400FM		T103L		T103T	
Material	Chrome-Plated Brass		Chrome-Plated Brass		Nickel Plated Brass		Nickel Plated Brass	
Port	FNPT		F x M NPT		FNPT		FNPT	
Size 1/4"	T400-1/4	\$4.15	T400FM-1/4	\$4.15				
3/8"	T400-3/8	\$4.26	T400FM-3/8	\$4.26				
1/2"	T400-1/2	\$5.33	T400FM-1/2	\$5.33	T103L-1/2	\$15.56		
3/4"							T103T-3/4	\$17.67
1"								
1 1/4"								
1 1/2"								
2"								

STC Digital Timer and Power Safe List Price

	Part No.	List Price	Voltage	Features
	2W200C-T	\$28.80	24-240VDC	ON/OFF Timer Switch ON/OFF Adjustment Duration: On 0.5 second to 10 seconds, Off 0.5 to 45 minutes. 24-AC 50/60HZ, 1A, DIN43650A Connection, for 2W200C, 2W350C, 2WO coils
	2W200C-T-D	\$47.23	24-240V	DIGITAL TIMER FOR 2W200C & 2W350C, ON/OFF TIMER, Adjustment: ON 0.5 TO 10 SECONDS, OFF 0.5 TO 45 MINUTES, FOR 2WO250C COIL For 2W200-350C coils, 50/60HZ, 1 AMP .
	2W200C-T-DH	\$59.29	110-240 DC/AC	PROGRAMMABLE DIGITAL ON/OFF Timer Switch ON/OFF Single or Multi Cycles Adjustment Duration: ON: 1 second to 99 hours OFF: 1 second to 99 hours Size: 88 X 48 x 21 (mm) Termination: DIN43650A Protection: IP65, EN60529, for 2W200C, 2W350C, 2WO coils
	2W200C-T-DL		7-36 DC/AC	
	2W200C-PS-H	\$11.41	110-280 VAC/VDC 10-28W 1A	POWER SAVE DEVICE High Power Start Up Time: 0.3 - 2.5 seconds Energy Save Rate: 15 to 85 % Power Up Grade: 20 to 300% (AC only) Size: 88 X 48 x 21 (mm) Termination: DIN43650A Protection: IP65, EN60529, for 2W200C, 2W350C, 2WO coils
	2W200C-PS-L		12-36 VAC/VDC 10-50W 2A	

STC Solenoid Valve Dimensions

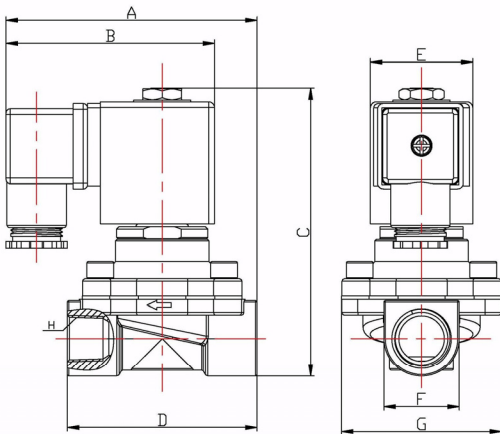
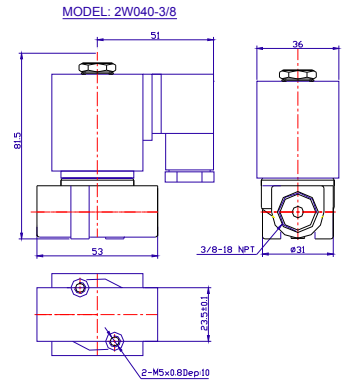
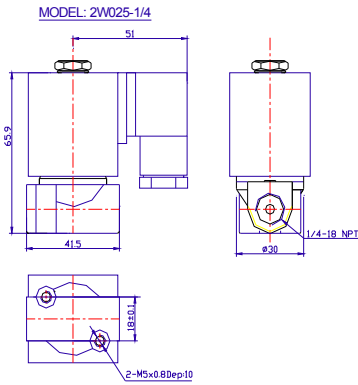
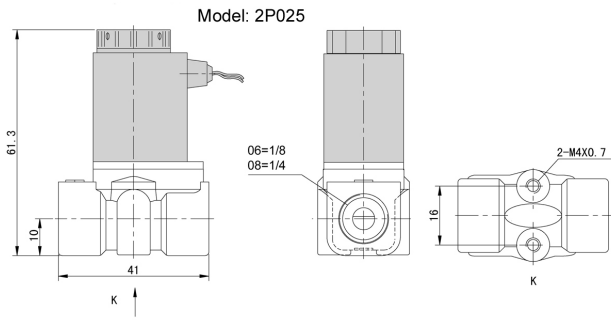

Model: 2S & 2W Series (MM)		A	B	C	D	E	F
2S160-3/8	2W160-3/8	101.5	57	117	69	50	36
2S160-1/2	2W160-1/2	101.5	57	117	69	50	36
2S200-3/4	2W200-3/4	107.0	57	124	73	50	36
2S250-1	2W250-1	111.5	74	135	99	50	36
2S350-1 1/4	2W350-1 1/4	142.0	95	172	123	70.5	56
2S400-1 1/2	2W400-1 1/2	142.0	95	172	123	70.5	56
2S500-2	2W500-2	172.0	123	209	168	70.5	56

MODEL: 2W & 2S 160-500 SERIES VALVES UNIT IN MM (NOT TO SCALE)

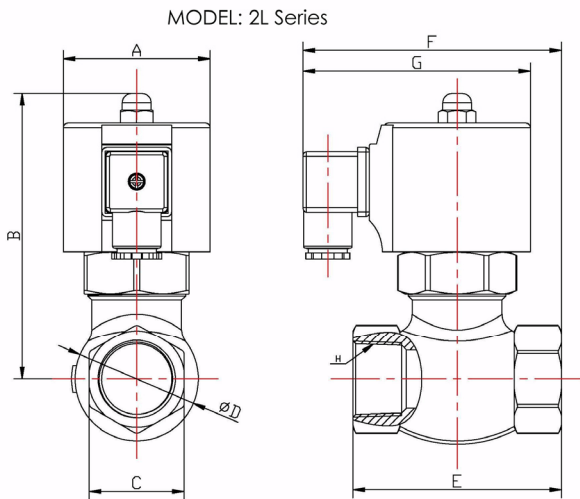

Model: 2L Series Dimensions (MM)							
Model	Port Size H (NPT)	A	B	C (hex)	E	F	G
2L170-3/8	3/8	63	125	25.4	82	109	99
2L170-1/2	1/2	63	125	29.5	82	109	99
2L170-3/4	3/4	63	125	35	82	109	99
2L200-1	1	63	125	41	91	113	99
2L300-1 1/2	1 1/2	63	145	55	112	124	99
2L500-2	2	63	183	72	165	150	99

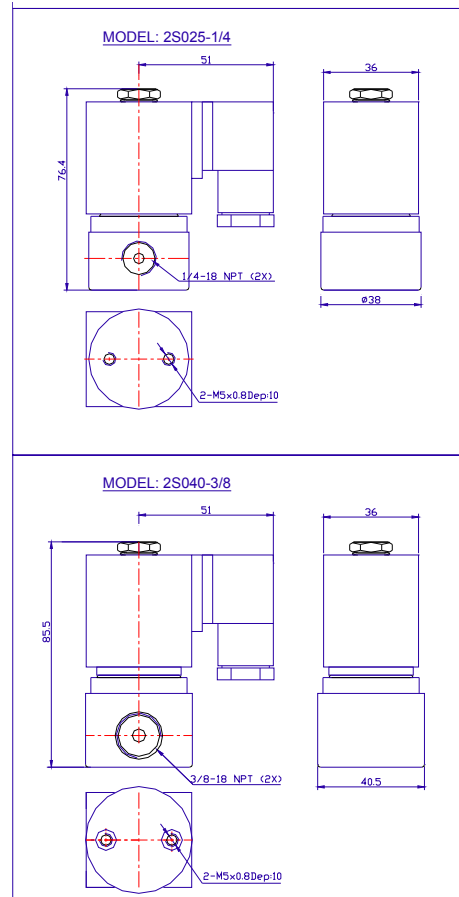

STC Solenoid Valve Dimensions



2H012

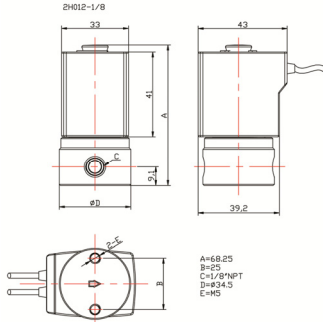

High pressure stainless steel solenoid valve Specifications & Dimensions (mm) High Performance, high pressure, fast response, direct acting solenoid valve, stainless steel wetted surfaces.										
MODEL	PORT	Cv (Orifice)	A	B	C	D	E	F	Pressure	Temperature
2H012	1/8"	0.05 (1.2MM)	65.5	30	1/8"	17	15.5	M4	0-1000 PSI	0-85°C
2H016	1/8"	0.085 (1.6MM)	65.5	30	1/8"	17	15.5	M4	0-500 PSI	0-85°C

2H080-250

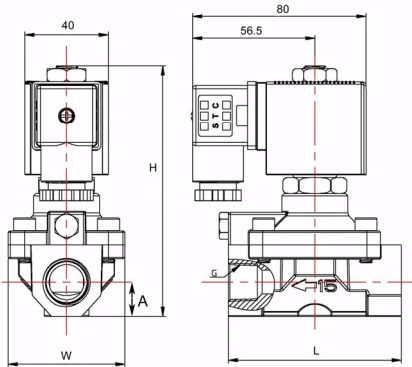

High pressure brass solenoid valve Specifications & Dimensions (mm)										
Model	Port	Orifice	A	L	W	Pressure (psi)	Medium Temp °C	Ambient Temp °C	Power Consumption	
									AC (VA)	DC (W)
2H080	1/4"	8	16	65	34	45 to 725	-20 to 90	-20 to 50	14	8
2H100	3/8"	10	16	65	34	45 to 725	-20 to 90	-20 to 50	14	8
2H130	1/2"	13	16	65	34	45 to 725	-20 to 90	-20 to 50	14	8
2H200	3/4"	20	20	90	60	45 to 500	-20 to 90	-20 to 50	14	8
2H250	1"	25	20	116	70	45 to 500	-20 to 90	-20 to 50	14	8

2M/2MO/2MS/2MSO

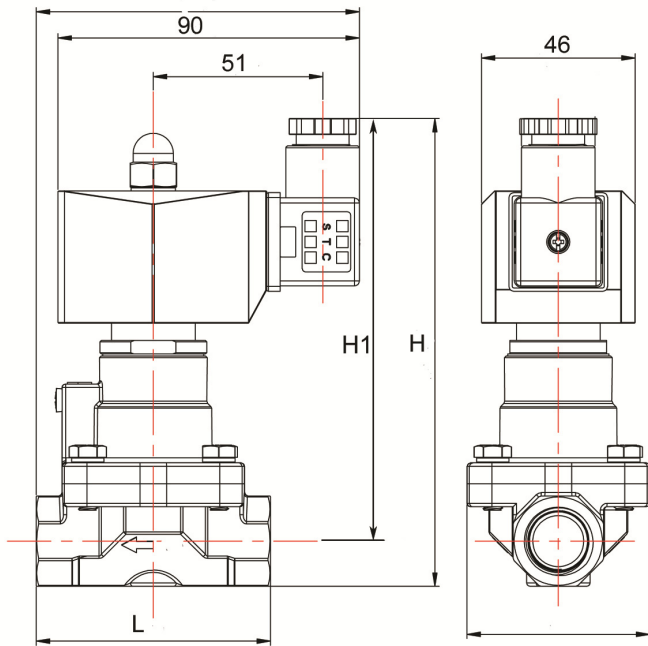

Model: 2M Series Dimensions (MM)														
Normally Closed (NC)		Normally Open (NO)		Port Size H (NPT)	Orifice	Cv	L	H1	H	Pressure (psi)		Power Consumption		
Brass	Stainless Steel	Brass	Stainless Steel							NC	NO		Medium Temperature	Ambient Temperature
2M150-1/2	2MS150-1/2	2MO150-1/2	2MSO150-1/2	1/2	15	4.5	75	117	140	6 to 230	6 to 145	-4 to 356°F	-4 to 122°F	20-30W
2M200-3/4	2MS200-3/4	2MO200-3/4	2MSO200-3/4	3/4	20	7.6	75	122	147	6 to 230	6 to 145	-4 to 356°F	-4 to 122°F	20-30W
2M250-1	2MS250-1	2MO250-1	2MSO250-1	1	25	12	92	143	155	6 to 230	6 to 145	-4 to 356°F	-4 to 122°F	20-30W
2M320-1 1/4	2MS320-1 1/4	2MO320-1 1/4	2MSO320-1 1/4	1 1/4	32	22	110	143	155	6 to 230	6 to 145	-4 to 356°F	-4 to 122°F	20-30W
2M400-1 1/2	2MS400-1 1/2	2MO400-1 1/2	2MSO400-1 1/2	1 1/2	40	30	122	145	160	6 to 230	6 to 145	-4 to 356°F	-4 to 122°F	20-30W
2M500-2	2MS500-2	2MO500-2	2MSO500-2	2	50	48	161	157	179	6 to 230	6 to 145	-4 to 356°F	-4 to 122°F	20-30W

2T060

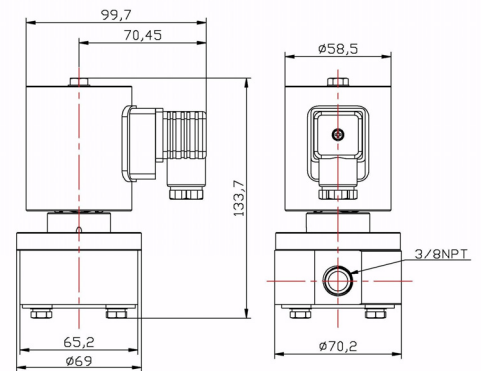

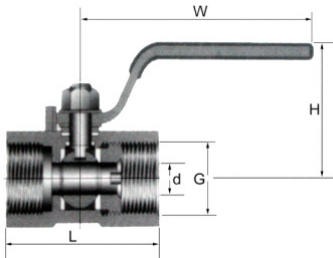
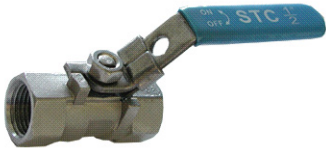

Model: V1 Specifications	
One Piece Reduced Port 316 Stainless Steel Ball Valve	
Maximum Operating Pressure: 1000 PSIG @ 100°F WOG*	
Operating Temperature Range: -60 to 450°F*	
End Connections: NPT Threaded with Padlocking device	

Dimensions (mm)					
SIZE	d	L	H	W	Wt (kg)
1/4"	5	39	35	64	0.07
3/8"	7	44	37	70	0.1
1/2"	9.2	56.5	43.5	90	0.16
3/4"	12.5	58	47	90	0.25
1"	15	70	50	103	0.43
1 1/4"	20	78	57	103	0.7
1 1/2"	24.5	83	69	127	0.83
2"	32	100	74.5	127	1.5

Main Parts and Materials			
No	Part Name	Material	Qty
1	SEAT	PTFE	2
2	BALL	SS316	1
3	JOINT GASKET	PTFE	1
4	CAP	SS316	1
5	BODY	SS316/CF8M	1
6	STEM	SS316	1
7	THRUST WASHER	PTFE	1
8	STEM PACKING	PTFE	1
9	GLAND NUT	SS304	1
10	STEM WASHER	SS304	1
11	STEM NUT	SS304	1
12	HANDLE COVER	PLASTIC	1
13	HANDLE	SS304	1

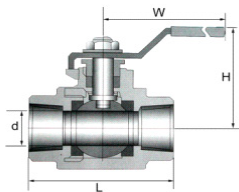

Model: V2 Specifications	
Two Piece Full Port 316 Stainless Steel Ball Valve	
Maximum Operating Pressure: 1/4" to 2" 1000 PSIG @ 100°F WOG* 2 1/2" to 3" 800 PSIG @ 100°F WOG*	
Temperature Range: -60 to 450°F*	
End Connections: NPT Threaded with Padlocking & Panel Mount Device	

Dimensions (mm)										
SIZE	1/4"	3/8"	1/2"	3/4"	1"	1 1/4"	1 1/2"	2"	2 1/2"	3"
d	11.6	12.7	15	20	25.4	32	38	50.8	65	76
L	55	55	63.5	75	88	103	110	124	167	192
H	48	48	50	57	69	73	83	92	136	149
W	103	103	103	125	145	145	190	190	250	250

Main Parts and Materials			
No	Part Name	Material	Qty
1	SEAT	PTFE	2
2	BALL	SS316	1
3	JOINT GASKET	PTFE	1
4	CAP	SS316	1
5	BODY	SS316/CF8M	1
6	STEM	SS316	1
7	THRUST WASHER	PTFE	1
8	STEM PACKING	PTFE	1
9	GLAND NUT	SS304	1
10	STEM WASHER	SS304	1
11	STEM NUT	SS304	1
12	HANDLE COVER	PLASTIC	1
13	HANDLE	SS304	1

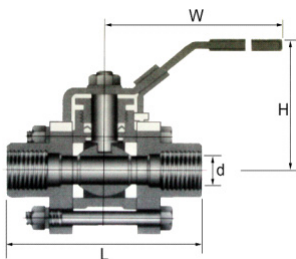

Model: V3 Specifications	
Maximum Operating Pressure: 1/2" to 2" 1000 PSI @ 100°F WOG* 2 1/2" to 3" 800 PSI @ 100°F WOG*	
Temperature Range: -60 to 450°F*	
Full Port	
End Connections: FNPT	
Mounting Options: Padlocking device and actuator mounting bracket	

Dimensions (mm)												
SIZE	1/4"	3/8"	1/2"	3/4"	1"	1 1/4"	1 1/2"	2"	2 1/2"	3"	4"	
d	mm	12.5	12.5	15	20	25	30	38	50	64	80	98
	in	0.49	0.49	0.59	0.79	0.98	1.18	1.5	1.97	2.52	3.15	3.86
H	mm	57	57	68	70	80	84	93	100	142	155	172
	in	2.24	2.24	2.68	2.76	3.15	3.31	3.66	3.94	5.59	6.1	6.77
W	mm	96	96	124	124	142	142	202	202	250	250	300
	in	3.78	3.78	4.88	4.88	5.99	5.99	7.95	7.95	9.84	9.84	11.81
L	mm	68	68	72	83	90	112	120	147	174	193	216
	in	2.56	2.56	2.84	3.35	3.62	4.33	4.48	5.59	6.85	7.6	8.5

Main Parts and Materials			
No	Part Name	Material	Qty
1	SEAT	PTFE	2
2	BALL	SS316	1
3	JOINT GASKET	PTFE	1
4	CAP	SS316	1
5	BODY, BODY CONNECTOR	SS316/CF8M	1, 2
6	STEM	SS316	1
7	THRUST WASHER	PTFE	1
8	STEM PACKING	PTFE	1
9	GLAND NUT	SS304	1
10	STEM WASHER	SS304	1
11	STEM NUT	SS304	1
12	HANDLE COVER	PLASTIC	1
13	HANDLE	SS304	1
14	BODY CONNECTOR BOLT	SS304	4
15	BODY CONNECTOR NUT & WASHER	SS304	4

STC Valve Technical Data

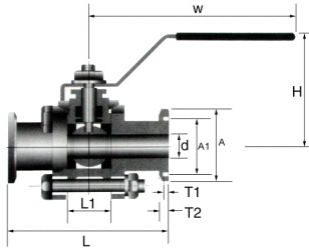

Model: V3C Specifications	
Sanitary Stainless Steel Ball Valve: These valves are made with precision machined Teflon seat for use in Sanitary applications. They are three piece design and have four bolts that permit quick and easy access to service the valve without disrupting the pipe line connections.	
Maximum Operating Pressure: 1/2" to 2" 1000 PSI @ 100°F WOG* 2 1/2" to 4" 800 PSI @ 100°F WOG*	
Temperature Range: -60 to 450°F*	
Full Port	
End Connections: Clamp End	
Mounting Options: Padlocking device and actuator mounting bracket	

Dimensions (mm)								
Size	Port (d)	L	A	A1	H	T1	T2	W
1/2"	9.6	75	25	20.24	64	--	3.63	125
3/4"	15.9	90	25	20.24	67	--	3.63	125
1"	22.2	100	50.4	43.6	83	2.85	4.75	140
1 1/4"	28.5	110	50.4	43.6	89	2.85	4.75	140
1 1/2"	34.9	125	50.4	43.6	100	2.85	--	200
2"	47.5	150	63.9	56.3	108	2.85	--	200
2 1/2"	60.2	190	77.4	70.6	150	2.85	--	250
3"	72.9	220	90	83.3	161	2.85	--	250
4"	97.4	270	118.9	110.3	180	2.85	--	250

Main Parts and Materials			
No	Part Name	Material	Qty
1	SEAT	PTFE	2
2	BALL	SS316	1
3	JOINT GASKET	PTFE	1
4	CAP	SS316	1
5	BODY, BODY CONNECTOR	SS316/CF8M	1, 2
6	STEM	SS316	1
7	THRUST WASHER	PTFE	1
8	STEM PACKING	PTFE	1
9	GLAND NUT	SS304	1
10	STEM WASHER	SS304	1
11	STEM NUT	SS304	1
12	HANDLE COVER	PLASTIC	1
13	HANDLE	SS304	1
14	CONNECTOR BOLT	SS304	4
15	CONNECTOR NUT & WASHER	SS304	4

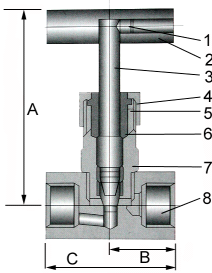

Model: VN01 Specifications					
End Connections: NPT threaded ASME b1.20.1					
DIN 2999 & BS21; ISO 228/1 & ISO 7/1					
Max. Operating Pressure: 6000 PSIG @ 100 °F*					
Operating Temperature Range: -60 to 450°F*					
Fire safe design					
Dimensions (mm)					
Size	1/4"	3/8"	1/2"	3/4"	1"
A	75	75	87	90	103
B	25	25	30	32.5	40
C	50	50	60	65	80
Cv	0.43	0.74	1.36	2.64	3.6
Panel Hole	20	20		22	24

Main Parts and Materials		
No	Part Name	Material
1	SET SCREW	SS304
2	HANDLE	SS410
3	STEM	SS316
4	GLAND NUT	SS304
5	GLAND	SS304
6	PACKING	TEFLON
7	BONNET	SS316/CF8M
8	BODY	SS316/CF8M

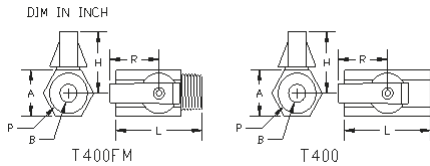

Valve Specifications		
Valve Type	T400	T400FM
Operating Pressure	0-450 PSI @ 75 °F	
Operating Temperature	0 TO 200 Deg. F	
Ball	Chrome Plated Brass	
Body Materials	Chrome or Nickel Plated Brass	
Seal Materials	PTFE	
Handel	Metal or Plastic	
Service	Air, Liquid	

	A	B (BORE)	H	L	P (NPT)	R
T400 1/4	0.80	0.31	1.00	1.58	1/4	0.93
T400 3/8	0.80	0.31	1.00	1.58	3/8	0.93
T400 1/2	0.96	0.39	1.10	1.78	1/2	0.93
T400FM 1/4	0.80	0.31	1.00	1.58	1/4	0.93
T400FM 3/8	0.80	0.31	1.00	1.58	3/8	0.93
T400FM 1/2	0.96	0.39	1.10	1.78	1/2	0.93

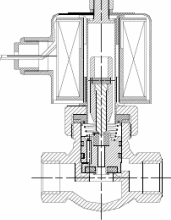
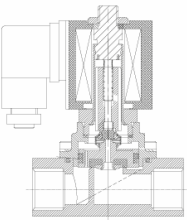
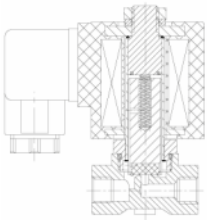
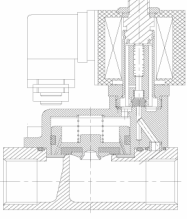
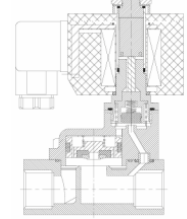
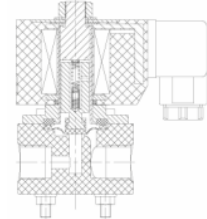
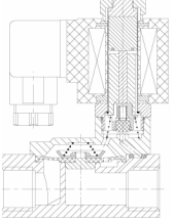
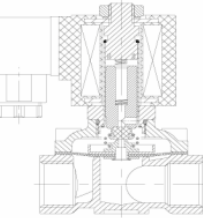
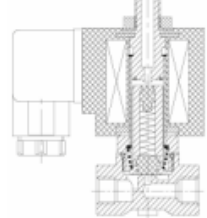
<p>2L: Brass</p> <p>2 Way NC Direct Lift Piston</p>		<p>2LS: Stainless Steel</p> <p>2 Way NC Direct Lift Piston</p>		<p>2H: Stainless 2P: Plastic 2V: Aluminum 2S/25-050: SS 2W/25-040: Brass</p> <p>2 Way NC Direct Acting</p>	
<p>2MS: Stainless Steel</p> <p>2 Way NC Pilot Piston</p>		<p>2MSO: Stainless Steel</p> <p>2 Way NO Pilot Piston</p>		<p>2T: Teflon</p> <p>2 Way NC Direct Lift Diaphragm</p>	
<p>2V130: Brass</p> <p>2 Way NC Pilot Diaphragm</p>		<p>2W/2WO160-500: Brass 2S/2SO160-500: SS</p> <p>2 Way NC Direct Lift Diaphragm</p>		<p>3W: Brass</p> <p>3 Way NC Direct Acting</p>	

Valve Components	Materials	Seals Options:	Temperature Range/Compatibility
Body	Options: Aluminum, Brass, Plastic, Stainless Steel, Teflon	NBR	-10~90°C, Oil-resistant and petroleum-resistant, not good for oxygen
Armature Tube	Stainless Steel 304	EPDM	-30~130°C, Withstand ozone, resistant to corrosive chemical materials, not suitable for oil
Plunger	Stainless Steel 430F	PTFE	-20~200°C, Resistant to most chemicals, except compound with oxygen
Head	Stainless Steel 430F	VITON	-10~150°C, Resistant to most chemicals
Springs	Stainless Steel 304		
Shading Rings	Brass (Option: Silver)		

Air & Electric Actuated Valves

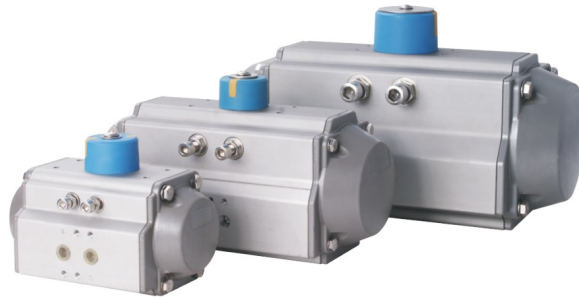

Precision Engineered

Fine Quality



Advanced Design

Excellent Prices



Contents

Air Actuated Ball Valve Numbering System.....	D2
Air Actuated Ball Valve List Price.....	D3
Air Actuated Ball Valve Specifications	D4
Rotary Air Actuator Dimensions & Specifications.....	D5
Electric Actuator List Price & Specifications	D6
Air Actuated Angle Seat Valve List Price & Specifications.....	D7
Actuated Angle Seat Valve Technical Data & Dimensions.....	D8

Air Actuated Ball Valve Numbering System

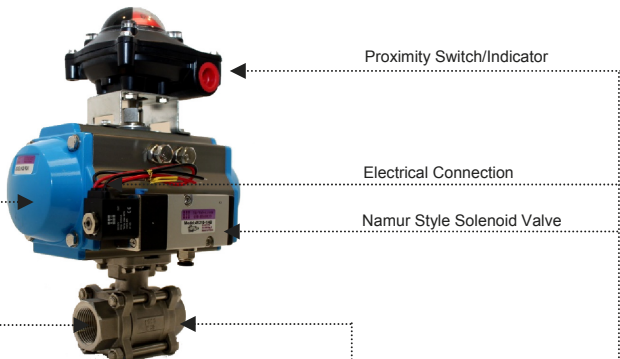



Ordering Part No. =
(eg. **KS1/2- - - S2NP**)



Model	Port Size (in)	Connection	Valve Type	Valve Material	Options
KS = Single Acting (Spring Return) KD = Double Acting (Air Return)	1/2	Blank = NPT C = Tri-Clamp F = Flange G = BSPP R = BSPT S = Socket Weld W = Butt Weld	Blank = 2 Way, Normally Closed O = 2 Way, Normally Open L = 3 Way (L Port) T = 3 Way (T Port)	Blank = 316 Stainless Steel B = Brass	S = Namur solenoid valve Coil Voltage: 1 = 12VDC 2 = 24VDC 2A = 24VAC 3 = 110 VAC 50/60HZ 4 = 220 VAC 50/60HZ Coil Electrical: D = DIN G = 2 Lead Wires N = 1/2 NPT for Conduit E = Explosion Proof Coil P = Proximity Switch, 2 SPDT (APL-210N) X = Proximity Switch, 2 SPDT, Exp. Proof (APL-410)
	3/4				
	1				
	1 1/4				
	1 1/2				
	2				
	2 1/2				
	3				
4					

Air Actuated Ball Valve List Price

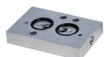

Air Actuated Valve List Price						
ROTARY PNEUMATIC BALL VALVE	Port Size NPT	Air Actuated Single Acting		Air Actuated Double Acting		
		Model	Price	Model	Price	
	1/4"	KS-1/4	\$216.60	KD-1/4	\$187.80	Fluid Temperature: w/ PTFE seal, -10°C to 180°C VACUUM TO 1000 PSI Service: Air, Gas, Liquid, Steam, Vacuum
	3/8"	KS-3/8	\$216.60	KD-3/8	\$187.80	
	1/2"	KS-1/2	\$216.60	KD-1/2	\$187.80	
	3/4"	KS-3/4	\$228.12	KD-3/4	\$193.55	
	1"	KS-1	\$262.68	KD-1	\$239.64	
	1 1/4"	KS-1 1/4	\$343.33	KD-1 1/4	\$274.21	
	1 1/2"	KS-1 1/2	\$458.55	KD-1 1/2	\$354.85	
	2"	KS-2	\$607.17	KD-2	\$423.98	
	3"	KS-3	\$1,149.81	KD-3	\$1,034.60	
4"	KS-4	\$2,637.18	KD-4	\$2,442.37		

Namur Solenoid Valves for Controlling Air Actuated Valves						
Part No. = Model - Voltage Option - Electrical Options						
		Model	Voltage Options	Electrical Options	Non-Exp. Proof	Exp. Proof
	3 Way Namur Single Solenoid Valve	3V310B-1/4	1 = 12 VDC 2 = 24VDC 2A=24VAC 3 = 110VAC 4 = 220VAC (60/60Hz)	D = DIN G = Grommet (12" Lead Wire) E = Explosion Proof	\$43.35	\$196.17
	3 Way Namur Double Solenoid Valve	3V320B-1/4			\$58.71	\$289.43
	4 Way Namur Single Solenoid Valve	4V310B-1/4			\$43.35	\$196.17
	4 Way Namur Double Solenoid Valve	4V320B-1/4			\$58.71	\$289.43
	Flow Control for Namur Valve	ASC N1/4B				

STC Proximity Switches/Position Indicators						
	Part No.	List Price	Voltage	Current	Cable Entry	
	APL-210N	\$81.00	Max. 250VAC or DC	5A @ 8 to14VDC 4A @ 30VDC 0.4A @ 125VDC 0.2A @ 250VDC 5A @ 125VAC, 3A @ 250VAC	2-1/2 NPT	Position Indicator for Rotary Actuator, IP 67 ENCLOSURE 2 SPDT Mechanical Limit Switches, Visual OPEN/CLOSED Indicator
	APL-310N	\$141.71		0.6A 125VDC, 0.3A 250V DC 16A 125 to 250VAC	2-1/2 NPT	Position Indicator for Rotary Actuator, 2 SPDT Mechanical Limit Switches, Visual OPEN/CLOSED Indicator
	APL-410	\$283.42		0.6A 125VDC, 0.3A 250VDC 15A 125 to 250 VAC	2-3/4 NPT	Explosion Proof Position Indicator for Rotary Actuator, Exd II BT6, IP 67 ENCLOSURE, 2 SPDT Mechanical Limit Switches, Visual OPEN/CLOSED Indicator

Actuated Valve Body Specifications	
Valve Body & Ball	316 Stainless Steel/CF8M
Seat Seals & Packing	PTFE
Service Medium	Air , Gas, Liquid, Steam, Water,
Operating Pressure	3/8" to 2": 1000 PSI @ 100°F WOG 2 1/2" to 4" : 800 PSI @ 100°F WOG
Media Temperature	- 60 to 450 °F
Ambient Temperature	-4 to 176 °F (-20 TO 80 °C)
Maximum Viscosity	600 mm ² /s
Installation Orientation	Any Orientation
Controlling Medium	Air, Inert Gas
Controlling Pressure Range	45-120 PSI
Mounting standard	DIN 3203-M3, ISO 5211 MOUNTING PAD, ISO5211 PLATFORM
Port	2 Way: Full Port 3 Way: Reduced Port

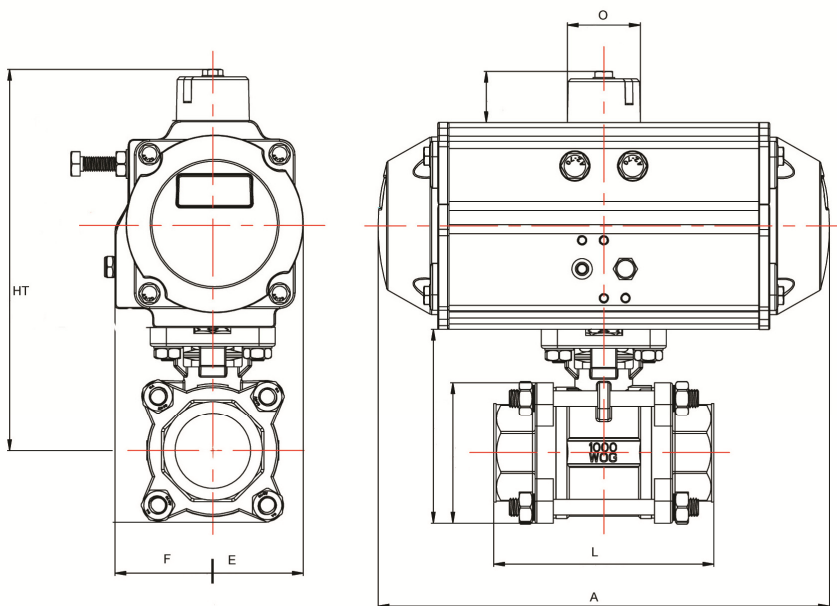
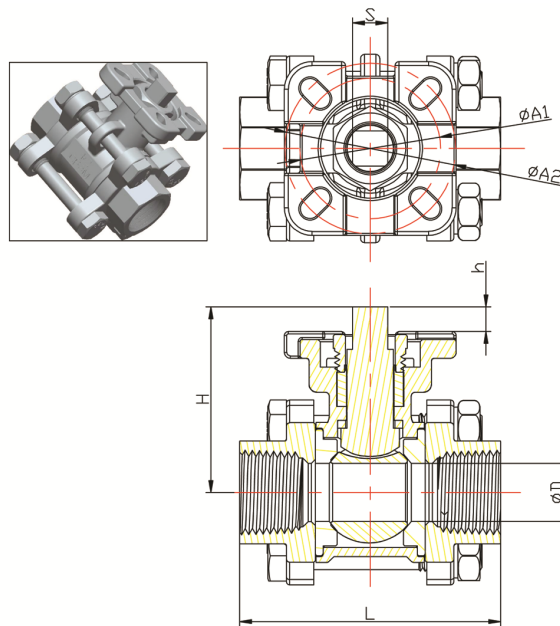

Actuated Valve Body Dimensions (mm)																	
2 WAY	3 WAY	SIZE	D	L	H	h	S	Actuator Mounting: ISO05211		Actuator Bore Size (MM)							
								A1/(MM)	A2/(MM)	Single Acting	A	F+E	HT	Double Acting	A	F+E	HT
V3-1/2-A	V-1/2-L-A	1/2"	15	75	38	9	9	F03/36	F04/42	63	190	80	103	32	110	45.5	103
V3-3/4-A	V-3/4-L-A	3/4"	20	80	47	9	9	F03/36	F04/42	63	190	80	112	50	143	71	139
V3-1-A	V-1-L-A	1"	25	90	57.2	11	11	F04/42	F05/50	63	190	80	122.2	50	143	71	149.2
V3-1 1/4-A	V-1 1/4-L-A	1 1/4"	32	110	62.5	11	11	F04/42	F05/50	75	207	91	182	63	190	80	170.5
V3-1 1/2-A	V-1 1/2-L-A	1 1/2"	38	120	77.5	14	14	F05/50	F07/70	88	213	98.5	206.5	63	190	80	185.5
V3-2-A	V-2-L-A	2"	50	140	86.5	14	14	F05/50	F07/70	88	213	98.5	215.5	75	207	91	206
V3-2 1/2-A	V-2 1/2-L-A	2 1/2"	65	162	108	17	17	F07/70	F10/102	100	267	121	261	88	213	98.5	237
V3-3-A	V-3-L-A	3"	80	184	115	17	17	F07/70	F10/102	125	340	137.5	290	100	267	121	268
V3-4-A	V-4-L-A	4"	100	228	141	22	22	F07/70	F10/102	145	414	151	332.5	125	340	137.5	316

Rotary Air Actuator Dimensions & Specifications

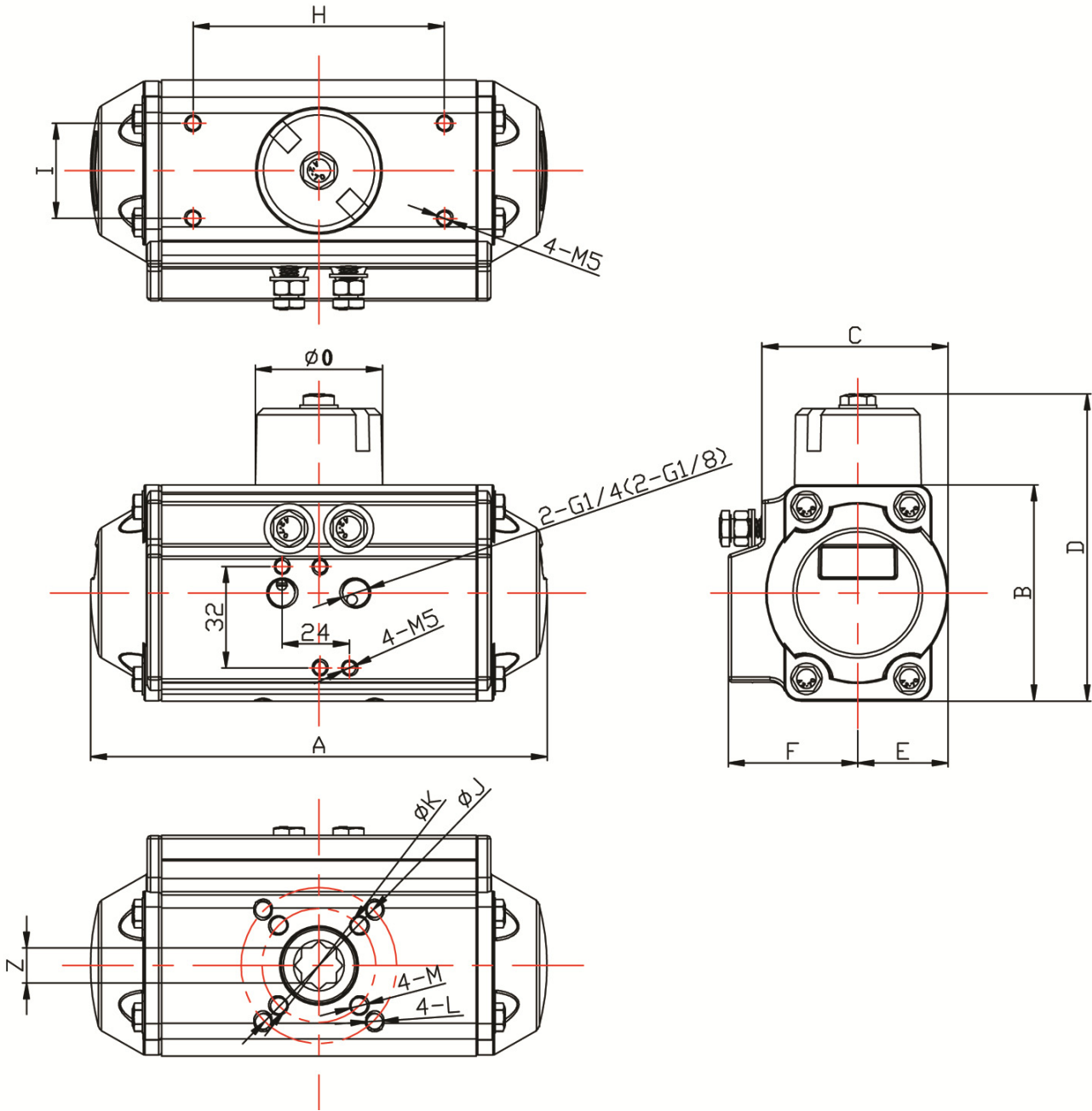

Model Double Acting	Model Single Acting	Size	A	B	C	D	E	F	G	H	I	J	K	L	M	N	O	A120	A180	AIR CONNECTION
AT032D	AT032S	32	110	45	45	65	22.5	23	12	50	25		F03/36		M5X5	9				G1/8
AT050D	AT050S	50-52	143	72	55	92	30	41	14	80	30	F05/50	F03/36	M6X8	M5X8	11	40	158	200	G1/4
AT063D	AT063S	63	190	88	69	108	35	45	18	90	30	F07/70	F05/50	M8X13	M6X10	14	40	184	233	G1/4
AT075D	AT075S	75	207	99.5	100.5	119.5	38.5	52.5	20.5	80	30	F07/70	F05/50	M8X10	M6X8	14	40	203	243	G1/4
AT088D	AT088S	85-88	213	109	88	129	46	52.5	21	80	30	F07/70	F05/50	M8X13	M6X10	17	40	221	280	G1/4
AT092D	AT092S	92	258	117	98.5	137	50	61	21	80	30	F07/70	F05/50	M8X12	M6X10	17	40	280	374	G1/4
AT0100D	AT0100S	100-105	267	133	109	153	57	64	26	80	30	F10/102	F07/70	M10X13	M8X10	22	40	304	388	G1/4
AT125D	AT125S	125	340	155	120.5	175	67.5	70	27.5	80	30	F10/102	F07/70	M10X16	M8X13	22	65	365	470	G1/4
AT145D	AT145S	140-145	414	171.5	132	191.5	75	76	32	80	30	F12/125	F10/102	M12X20	M10X15	27	65	442	568	G1/4

NOTE: A120 and A180 represent the acting length of the 120° rotation travel and 180° rotation travel, respectively.

Ordering Part No. =
(eg. E1/2--3T)

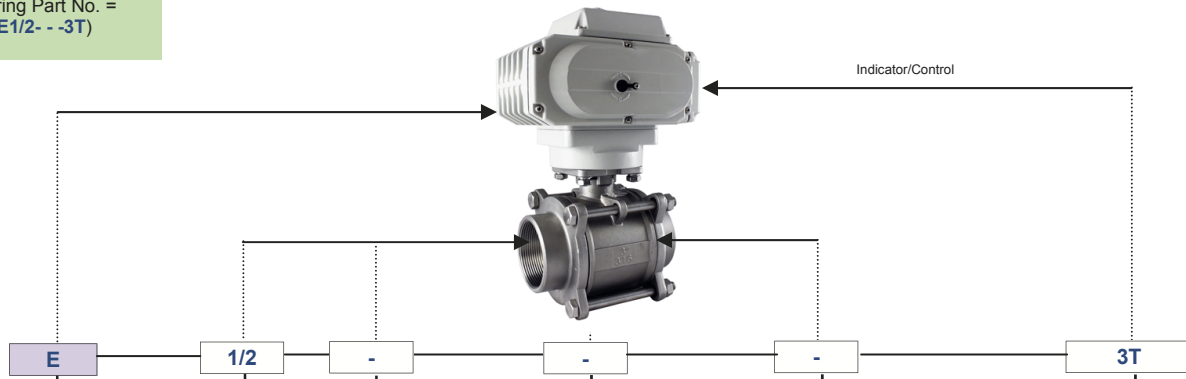

Model	Port Size (in)	Connection	Valve Type	Valve Material	Options
Electric Actuated Valves	1/2	Blank = NPT	Blank = 2 Way, Normally Closed O = 2 Way, Normally Open L = 3 Way (L Port) T = 3 Way (T Port)	Blank = 316 Stainless Steel	Voltage Option (V): 2 = 24VDC 2A = 24VAC 3 = 110 VAC 50/60HZ 4 = 220 VAC 50/60HZ Control Signal: Blank = Light Indicator S = Contact signal R = 1K, 5K potentiometer T = 4-20 mA (for Proportional Control)
	3/4	C = Tri-Clamp			
	1	F = Flange			
	1 1/4	G = BSPP			
	1 1/2	R = BSPT			
	2	S = Socket Weld			
	2 1/2	W = Butt Weld			
	3				

Valve Body	2 Way Valve with Actuator with ON/OFF Indicator		2 Way Valve with Actuator with Contact Signal		2 Way Valve with Actuator with Proportional Control		3 Way (L Ball) with Actuator with ON/OFF Indicator		3 Way (T Ball) with Actuator with ON/OFF Indicator	
	Port Size (NPT)	Part No.	Price	Part No.	Price	Part No.	Price	Part No.	Price	Part No.
1/4	E 1/4-V	\$527.01	E 1/4-V-S	\$574.03	E 1/4-V-T	\$1,090.89	E 1/4-L-V	\$541.55	E 1/4-T-V	\$541.55
3/8	E 3/8-V	\$527.01	E 3/8-V-S	\$574.03	E 3/8-V-T	\$1,090.89	E 3/8-L-V	\$541.55	E 3/8-T-V	\$541.55
1/2	E 1/2-V	\$527.01	E 1/2-V-S	\$574.03	E 1/2-V-T	\$1,090.89	E 1/2-L-V	\$541.55	E 1/2-T-V	\$541.55
3/4	E 3/4-V	\$537.65	E 3/4-V-S	\$584.67	E 3/4-V-T	\$1,101.53	E 3/4-L-V	\$561.84	E 3/4-T-V	\$561.84
1	E 1-V	\$566.73	E 1-V-S	\$613.75	E 1-V-T	\$1,130.61	E 1-L-V	\$599.21	E 1-T-V	\$599.21
1 1/4	E 1 1/4-V	\$600.20	E 1 1/4-V-S	\$647.21	E 1 1/4-V-T	\$1,164.08	E 1 1/4-L-V	\$684.25	E 1 1/4-T-V	\$684.25
1 1/2	E 1 1/2-V	\$688.91	E 1 1/2-V-S	\$735.93	E 1 1/2-V-T	\$1,252.79	E 1 1/2-L-V	\$827.71	E 1 1/2-T-V	\$827.71
2	E 2-V	\$924.16	E 2-V-S	\$971.18	E 2-V-T	\$1,488.04	E 2-L-V	\$1,079.04	E 2-T-V	\$1,079.04
2 1/2	E 2 1/2-V	\$1,163.52	E 2 1/2-V-S	\$1,210.54	E 2 1/2-V-T	\$1,727.41				
3	E 3-V	\$1,692.13	E 3-V-S	\$1,739.09	E 3-V-T	\$2,256.00				
4	E 4-V	\$2,259.95	E 4-V-S	\$2,306.97	E 4-V-T	\$2,823.83				

Electric Actuator	Part No.	List Price	Torque	Cycle Time	Weight	Special function	Control Signal	Ball Valve Size, NPT Diameter (DN)	Butterfly Valve Size Diameter (DN)	Rotation
	E-05	\$469.89	50N * M	20S	2.6Kg	On-off Light	Light Indicator	1/2" to 1 1/2" (15-40)	1" to 2 1/2" (32-65)	90°
	E-10	\$657.86	100N * M	30/60S	3.7Kg			2" to 2 1/2" (50-65)	2" to 4" (50-125)	
	E-20	\$892.84	200N * M	30/60S	6.7Kg			2 1/2" to 3" (65-80)	6" to 8" (150-200)	
	E-40	\$939.80	400N * M	30/60S	7.2Kg			3" to 4" (80-100)	8" to 10" (200-250)	
	E-60	\$1,174.77	600N * M	45S	7.3Kg			4" (100-125)	10" to 12" (250-300)	
	E-100	\$1,503.67	1000N * M	50S	7.3Kg			6" (125-150)	12" to 16" (300-400)	
	E-200	\$1,691.69	2000N * M	100S	11.2Kg	Passive Contact	S=Contact Signal	6" to 12" (150-300)	18" to 28" (450-700)	90°
	E-05S	\$516.92	50N * M	20S	2.6Kg			1/2" to 1 1/2" (15-40)	1" to 2 1/2" (32-65)	
	E-10S	\$704.87	100N * M	30/60S	3.7Kg			2" to 2 1/2" (50-65)	2" to 4" (50-125)	
	E-20S	\$939.80	200N * M	30/60S	6.7Kg			2 1/2" to 3" (65-80)	6" to 8" (150-200)	
	E-40S	\$986.81	400N * M	30/60S	7.2Kg			3" to 4" (80-100)	8" to 10" (200-250)	
	E-60S	\$1,221.79	600N * M	45S	7.3Kg			4" (100-125)	10" to 12" (250-300)	
	E-100S	\$1,550.69	1000N * M	50S	7.3Kg	Opening Signal	R=potentiometer (1-5K)	6" (125-150)	12" to 16" (300-400)	90°
	E-200S	\$1,738.60	2000N * M	100S	11.2Kg			6" to 12" (150-300)	18" to 28" (450-700)	
	E-05R	\$610.90	50N * M	20S	2.6Kg			1/2" to 1 1/2" (15-40)	1" to 2 1/2" (32-65)	
	E-10R	\$798.58	100N * M	30/60S	3.7Kg			2" to 2 1/2" (50-65)	2" to 4" (50-125)	
	E-20R	\$1,033.78	200N * M	30/60S	6.7Kg			2 1/2" to 3" (65-80)	6" to 8" (150-200)	
	E-40R	\$1,080.79	400N * M	30/60S	7.2Kg			3" to 4" (80-100)	8" to 10" (200-250)	
	E-60R	\$1,315.72	600N * M	45S	7.3Kg	Proportional Control	T=4-20mA	4" (100-125)	10" to 12" (250-300)	90°
	E-100R	\$1,644.67	1000N * M	50S	7.3Kg			6" (125-150)	12" to 16" (300-400)	
	E-200R	\$1,832.63	2000N * M	100S	11.2Kg			6" to 12" (150-300)	18" to 28" (450-700)	
	E-05T	\$1,033.78	50N * M	20S	2.6Kg			1/2" to 1 1/2" (15-40)	1" to 2 1/2" (32-65)	
	E-10T	\$1,221.73	100N * M	30/60S	3.7Kg			2" to 2 1/2" (50-65)	2" to 4" (50-125)	
	E-20T	\$1,456.71	200N * M	30/60S	6.7Kg			2 1/2" to 3" (65-80)	6" to 8" (150-200)	
	E-40T	\$1,503.67	400N * M	30/60S	7.2Kg	Proportional Control	T=4-20mA	3" to 4" (80-100)	8" to 10" (200-250)	90°
	E-60T	\$1,738.60	600N * M	45S	7.3Kg			4" (100-125)	10" to 12" (250-300)	
	E-100T	\$2,067.61	1000N * M	50S	7.3Kg			6" (125-150)	12" to 16" (300-400)	
	E-200T	\$2,302.58	2000N * M	100S	11.2Kg			6" to 12" (150-300)	18" to 28" (450-700)	

STC Air Actuated Angle Seat Valve Numbering System

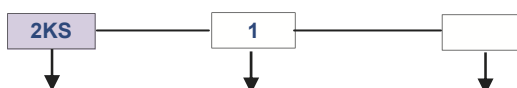

	AIR ACTUATED VALVE	Model	Port Size (NPT)	Options
	Single Acting (Spring Return)	2KS	3/8" 1/2" 3/4" 1"	Blank = NPT C = Tri-Clamp F = Flange R = BSPT W = Butt Weld
	Double Acting (Fail Closed)	2KD	1 1/4" 1 1/2" 2"	

316 Stainless Steel Air Actuated Angle Seat Valve List Price

ROTARY PNEUMATIC BALL VALVE	Port Size NPT	Single Acting (Normally Closed)		Double Acting (Fail Closed)	
		Model	Price	Model	Price
	3/8	2KS-3/8	\$177.37	2KD-3/8	\$177.37
	1/2	2KS-1/2	\$192.18	2KD-1/2	\$192.18
	3/4	2KS-3/4	\$197.07	2KD-3/4	\$197.07
	1	2KS-1	\$242.41	2KD-1	\$242.41
	1 1/4	2KS-1 1/4	\$344.89	2KD-1 1/4	\$344.89
	1 1/2	2KS-1 1/2	\$364.53	2KD-1 1/2	\$364.53
	2	2KS-2	\$502.55	2KD-2	\$502.55
	2 1/2	2KS-2	\$706.58	2KD-2	\$706.58

2KS & 2KD Specifications & Features

Operating Pressure	29" Hg Vacuum to 240 PSI (0-1.6MPa)
Temperature Range	-5 to 356°F (-20 to 180°C)
Ambient Temperature	-5 to 40°F (-20 to 60 °C)
Maximum Viscosity	600 mm ² /s (600 centistokes)
Installation Orientation	Any Orientation
Pilot Controlling Medium	Air, Inert Gas
Pilot Pressure Range	65-120 PSI
Wetted Surfaces	300 Series Stainless Steel and PTFE
Service Medium	Air, Gas, Liquid, Oil, Steam, Water, Vacuum

Materials of Construction

Valve Body	316 Stainless Steel
Valve Stem	316 Stainless Steel
Seat Seals	PTFE
Stem Seals	PTFE (Spring loaded self adjusting for long service life)
Actuator Body	Stainless Steel CF8 (Designed for harsh applications)
Piston	HPb59-1
Piston Ring V-Seals	NBR/FKM
Spring	Stainless Steel
Indicative stem	HPb59-1
Top Cap	Polycarbonate

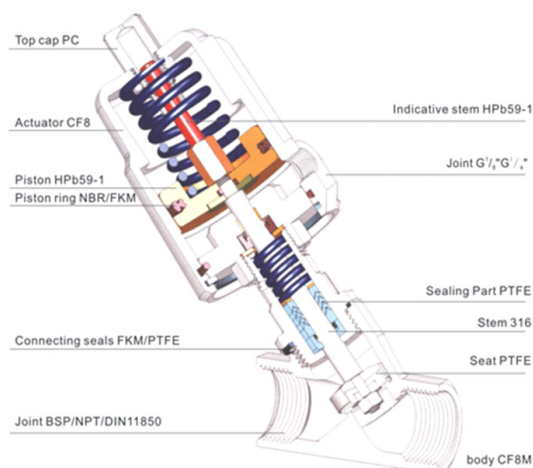

2KS Series Single Acting Stainless Steel Air Actuated Angle Seat Valve Specifications

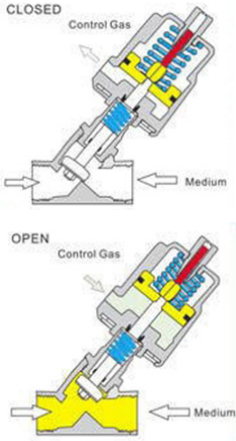

Part No.	Port (NPT)	Standard	Orifice (mm)	Actuator (mm)	Cv	Bi-directional Flow		Temperature	Pilot Control Pressure
						Inlet Above Seat Pressure @ 180 °C	Inlet Below Seat Pressure @ 180 °C		
2KS-3/8	3/8"	DN10	13	50	4.7	0-240 PSI (0-1.6MPa)	0-240 PSI (0-1.6MPa)	-5 to 356°F (-20 to 180°C)	65-120 PSI
2KS-1/2	1/2"	DN15	13	50	4.7	0-240 PSI (0-1.6MPa)	0-240 PSI (0-1.6MPa)	-5 to 356°F (-20 to 180°C)	65-120 PSI
2KS-3/4	3/4"	DN20	18	50	9.5	0-240 PSI (0-1.6MPa)	0-180 PSI (0-1.2MPa)	-5 to 356°F (-20 to 180°C)	65-120 PSI
2KS-1	1"	DN25	24	63	18.1	0-240 PSI (0-1.6MPa)	0-150 PSI (0-1.0MPa)	-5 to 356°F (-20 to 180°C)	65-120 PSI
2KS-1 1/4	1 1/4"	DN32	31	63	23.1	0-240 PSI (0-1.6MPa)	0-90 PSI (0-0.6MPa)	-5 to 356°F (-20 to 180°C)	65-120 PSI
2KS-1 1/2	1 1/2"	DN40	35	80	32.9	0-240 PSI (0-1.6MPa)	0-150 PSI (0-1.0MPa)	-5 to 356°F (-20 to 180°C)	65-120 PSI
2KS-2	2"	DN50	45	80	52.8	0-240 PSI (0-1.6MPa)	0-90 PSI (0-0.6MPa)	-5 to 356°F (-20 to 180°C)	65-120 PSI
2KS-2 1/2	2 1/2"	DN65	65	125	76	0-240 PSI (0-1.6MPa)	0-90 PSI (0-0.6MPa)	-5 to 356°F (-20 to 180°C)	65-120 PSI

2KD Series Double Acting Stainless Steel Air Actuated Angle Seat Valve Specifications

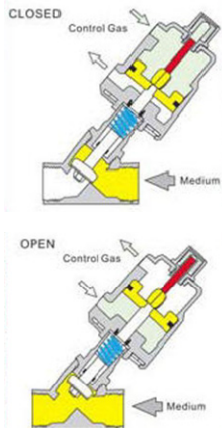

Part No.	Port (NPT)	Standard	Orifice (mm)	Actuator Diameter (mm)	Cv	Bi-directional Flow		Media Temperature	Pilot Control Pressure
						Inlet Above Seat Pressure @ 180 °C	Inlet Below Seat Pressure @ 180 °C		
2KD-3/8	3/8"	DN10	13	50	4.7	0-240 PSI (0-1.6MPa)	0-240 PSI (0-1.6MPa)	-5 to 356°F (-20 to 180°C)	65-120 PSI
2KD-1/2	1/2"	DN15	13	50	4.7	0-240 PSI (0-1.6MPa)	0-240 PSI (0-1.6MPa)	-5 to 356°F (-20 to 180°C)	65-120 PSI
2KD-3/4	3/4"	DN20	18	50	9.5	0-240 PSI (0-1.6MPa)	0-240 PSI (0-1.6MPa)	-5 to 356°F (-20 to 180°C)	65-120 PSI
2KDS-1	1"	DN25	24	63	18.1	0-240 PSI (0-1.6MPa)	0-240 PSI (0-1.6MPa)	-5 to 356°F (-20 to 180°C)	65-120 PSI
2KD-1 1/4	1 1/4"	DN32	31	63	23.1	0-240 PSI (0-1.6MPa)	0-240 PSI (0-1.6MPa)	-5 to 356°F (-20 to 180°C)	65-120 PSI
2KD-1 1/2	1 1/2"	DN40	35	80	32.9	0-240 PSI (0-1.6MPa)	0-240 PSI (0-1.6MPa)	-5 to 356°F (-20 to 180°C)	65-120 PSI
2KD-2	2"	DN50	45	80	52.8	0-240 PSI (0-1.6MPa)	0-240 PSI (0-1.6MPa)	-5 to 356°F (-20 to 180°C)	65-120 PSI
2KD-2 1/2	2 1/2"	DN65	65	125	76	0-240 PSI (0-1.6MPa)	0-240 PSI (0-1.6MPa)	-5 to 356°F (-20 to 180°C)	65-120 PSI

2KS/KD Series Stainless Steel Air Actuated Angle Seat Valve Dimensions

★ Overall Dimension

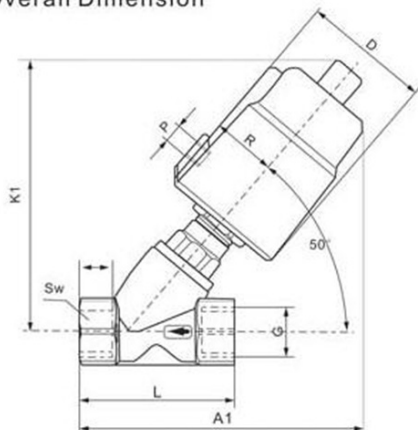

Single Acting	Double Acting	2KS/2KD Series Stainless Steel Air Actuated Angle Plunger Valve Dimensions (unit=mm)													
		Part No.	Part No.	Port (NPT)	Standard	Orifice (mm)	Actuator	Cv	A	R	P	K1	A1	L	T
2KS-3/8	2KD-3/8	3/8"	DN10	13	50	4.7	60	35	1/8	126	133	68	12	26.6	
2KS-1/2	2KD-1/2	1/2"	DN15	13	50	4.7	60	35	1/8	126	133	68	15	26.6	
2KS-3/4	2KD-3/4	3/4"	DN20	18	50	9.5	60	35	1/8	131	137	75	16	32	
2KS-1	2KD-1	1"	DN25	24	63	18.1	77	43	1/8	165	174	90	17	39.5	
2KS-1 1/4	2KD-1 1/4	1 1/4"	DN32	31	63	23.1	77	43	1/8	175	188	116	21	50	
2KS-1 1/2	2KD-1 1/2	1 1/2"	DN40	35	80	32.9	98	52	1/4	187	204	116	21	55.3	
2KS-2	2KD-2	2"	DN50	45	80	52.8	98	52	1/4	195	218	138	22	70	

Air Filter-Regulator-Lubricators

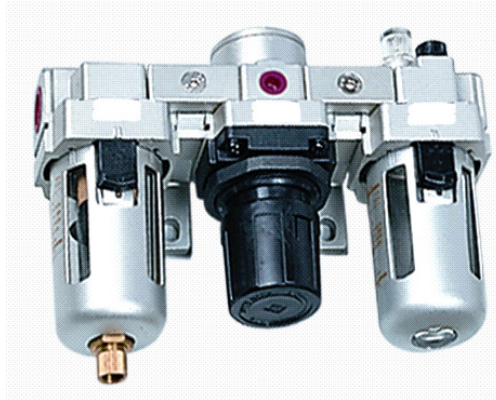

Precision Engineered

Fine Quality



Advanced Design

Excellent Prices

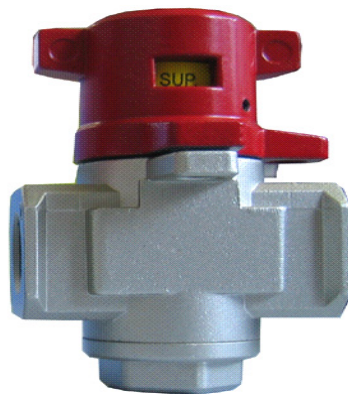
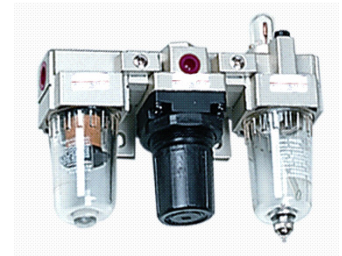

Contents

Filter Regulator Lubricator Numbering System.....	E2
Filter Regulator Lubricator List Price.....	E3-5
FRL Mounting Hardware List Price.....	E6
Filter Regulator Lubricator Flow Charts.....	E7-11
Filter Regulator Lubricator Dimensions.....	E12-15
Filter Regulator Lubricator Specifications.....	E16

Filter Regulator Lubricator Numbering System

Ordering Part No. =
(eg. AC 1000-00-D)

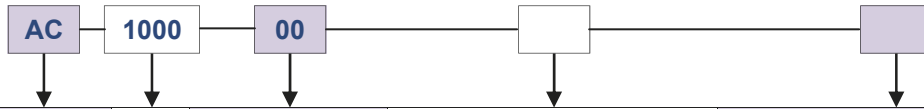

Model	Body Size	Port Size	Standard Features	Options
AC = Filter-Regulator-Lubricator AF = Filter AL = Lubricator AR = Regulator AW = Stacking Filter-Regulator VHS = Relieving Shut-off/Lockout Valve	1000 2000 3000 4000 5000	00 = 10-32 (M5) 01 = 1/8 NPT 02 = 1/4 NPT 03 = 3/8 NPT 04 = 1/2 NPT 06 = 3/4 NPT 10 = 1 NPT	Blank = Standard Features: Polycarbonate Bowl (3000-5000 Series with Steel Bowl Shield) 125 PSI Regulating Range Semi-auto Differential Drain 25 Micron Sintered Brass Filter	D = Automatic Drain DC = Drain Cock (with manual shut off valve) M = Metal Bowl (with sight glass) P30 = 30PSI Regulating Range P60 = 60 PSI Regulating Range F5 = 5 Micron Filter N = Without B = Bracket G = Pressure Gauge
AC = Stacking Filter-Regulator-Lubricator	1010 2010 3010 4010 5010			

Air Filter-Regulator-Lubricator List Price



	Part No.	Description (*includes Bracket & Gauge)	List Price
 <p>Includes Bracket & Gauge</p>	AC 1000-M5	M5/10-32 Filter- Regulator- Lubricator* (3 SCFM)	\$53.95
	AC 2000-01	1/8" NPT Filter- Regulator- Lubricator* (18 SCFM)	\$56.64
	AC 2000-01D	1/8" NPT Filter- Regulator- Lubricator* with Auto Drain (18 SCFM)	\$76.01
	AC 2000-01M	1/8" NPT Filter- Regulator- Lubricator* Metal Bowl (18 SCFM)	\$68.40
	AC 2000-01DM	1/8" NPT Filter- Regulator- Lubricator* with Auto Drain & Metal Bowl (18 SCFM)	\$83.91
	AC 2000-02	1/4" NPT Filter- Regulator- Lubricator* (18 SCFM)	\$56.64
	AC 2000-02D	1/4" NPT Filter- Regulator- Lubricator* with Auto Drain (18 SCFM)	\$76.01
	AC 2000-02M	1/4" NPT Filter- Regulator- Lubricator* Metal Bowl (18 SCFM)	\$68.40
	AC 2000-02DM	1/4" NPT Filter- Regulator- Lubricator* with Auto Drain & Metal Bowl (18 SCFM)	\$86.12
 <p>Includes Bracket & Gauge</p>	AC 3000-02	1/4" NPT Filter- Regulator- Lubricator* (70 SCFM)	\$87.10
	AC 3000-02D	1/4" NPT Filter- Regulator- Lubricator* with Auto Drain (70 SCFM)	\$112.44
	AC 3000-02M	1/4" NPT Filter- Regulator- Lubricator* with Metal Bowl (70 SCFM)	\$102.30
	AC 3000-02DM	1/4" NPT Filter- Regulator- Lubricator* with Auto Drain & Metal Bowl (70 SCFM)	\$127.65
	AC 3000-03	3/8" NPT Filter- Regulator- Lubricator* (70 SCFM)	\$87.10
	AC 3000-03D	3/8" NPT Filter- Regulator- Lubricator* with Auto Drain (70 SCFM)	\$112.44
	AC 3000-03M	3/8" NPT Filter- Regulator- Lubricator* with Metal Bowl (70 SCFM)	\$102.30
	AC 3000-03DM	3/8" NPT Filter- Regulator- Lubricator* with Auto Drain & Metal Bowl (70 SCFM)	\$127.64
	AC 4000-03	3/8" NPT Filter- Regulator- Lubricator* (140 SCFM)	\$117.48
	AC 4000-03D	3/8" NPT Filter- Regulator- Lubricator* with Auto Drain (140 SCFM)	\$149.07
	AC 4000-03M	3/8" NPT Filter- Regulator- Lubricator* with Metal Bowl (140 SCFM)	\$147.90
	AC 4000-03DM	3/8" NPT Filter- Regulator- Lubricator* with Auto Drain & Metal Bowl (140 SCFM)	\$165.65
	AC 4000-04	1/2" NPT Filter- Regulator- Lubricator* (140 SCFM)	\$117.48
	AC 4000-04D	1/2" NPT Filter- Regulator- Lubricator* with Auto Drain (140 SCFM)	\$149.07
	AC 4000-04M	1/2" NPT Filter- Regulator- Lubricator* with Metal Bowl (140 SCFM)	\$147.90
	AC 4000-04DM	1/2" NPT Filter- Regulator- Lubricator* with Auto Drain & Metal Bowl (140 SCFM)	\$165.65
	AC 4000-06	3/4" NPT Filter- Regulator- Lubricator* (160 SCFM)	\$128.50
	AC 4000-06D	3/4" NPT Filter- Regulator- Lubricator* with Auto Drain (160 SCFM)	\$160.09
	AC 4000-06M	3/4" NPT Filter- Regulator- Lubricator* with Metal Bowl (160 SCFM)	\$158.91
	AC 4000-06DM	3/4" NPT Filter- Regulator- Lubricator* with Auto Drain & Metal Bowl (160 SCFM)	\$176.65
AC 5000-10	1" NPT Filter- Regulator- Lubricator* (180 SCFM)	\$161.96	
AC 5000-10D	1" NPT Filter- Regulator- Lubricator* with Auto Drain (180 SCFM)	\$203.78	
AC 5000-10M	1" NPT Filter- Regulator- Lubricator* with Metal Bowl (180 SCFM)	\$192.38	
AC 5000-10DM	1" NPT Filter- Regulator- Lubricator* with Auto Drain & Metal Bowl (180 SCFM)	\$237.13	
 <p>Includes Bracket & Gauge</p>	AC 1010-M5	M5/10-32 Stacking Filter- Regulator- Lubricator* (3 SCFM)	\$48.25
	AC 2010-01	1/8" NPT Stacking Filter- Regulator- Lubricator* (18 SCFM)	\$51.33
	AC 2010-01D	1/8" NPT Stacking Filter- Regulator- Lubricator* with Auto Drain (18 SCFM)	\$70.76
	AC 2010-01M	1/8" NPT Stacking Filter- Regulator- Lubricator* with Metal Bowl (18 SCFM)	\$61.47
	AC 2010-01DM	1/8" NPT Stacking Filter- Regulator- Lubricator* with Auto Drain & Metal Bowl (18 SCFM)	\$78.34
	AC 2010-02	1/4" NPT Stacking Filter- Regulator- Lubricator* (18 SCFM)	\$51.33
	AC 2010-02D	1/4" NPT Stacking Filter- Regulator- Lubricator* with Auto Drain (18 SCFM)	\$70.76
	AC 2010-02M	1/4" NPT Stacking Filter- Regulator- Lubricator* with Metal Bowl (18 SCFM)	\$63.28
	AC 2010-02DM	1/4" NPT Stacking Filter- Regulator- Lubricator* with Auto Drain & Metal Bowl (18 SCFM)	\$79.58
 <p>Includes Bracket & Gauge</p>	AC 3010-02	1/4" NPT Stacking Filter- Regulator- Lubricator* (60 SCFM)	\$71.85
	AC 3010-02D	1/4" NPT Stacking Filter- Regulator- Lubricator* with Auto Drain (60 SCFM)	\$97.21
	AC 3010-02M	1/4" NPT Stacking Filter- Regulator- Lubricator* with Metal Bowl (60 SCFM)	\$82.82
	AC 3010-02DM	1/4" NPT Stacking Filter- Regulator- Lubricator* with Auto Drain & Metal Bowl (60 SCFM)	\$104.55
	AC 3010-03	3/8" NPT Stacking Filter- Regulator- Lubricator* (60 SCFM)	\$71.85
	AC 3010-03D	3/8" NPT Stacking Filter- Regulator- Lubricator* with Auto Drain (60 SCFM)	\$97.21
	AC 3010-03M	3/8" NPT Stacking Filter- Regulator- Lubricator* with Metal Bowl (60 SCFM)	\$87.07
	AC 3010-03DM	3/8" NPT Stacking Filter- Regulator- Lubricator* with Auto Drain & Metal Bowl (60 SCFM)	\$104.91
	AC 4010-03	3/8" NPT Stacking Filter- Regulator- Lubricator* (105 SCFM)	\$103.79
	AC 4010-03D	3/8" NPT Stacking Filter- Regulator- Lubricator* with Auto Drain (105 SCFM)	\$135.39
	AC 4010-03M	3/8" NPT Stacking Filter- Regulator- Lubricator* with Metal Bowl (105 SCFM)	\$134.21
	AC 4010-03DM	3/8" NPT Stacking Filter- Regulator- Lubricator* with Auto Drain & Metal Bowl (105 SCFM)	\$151.94
	AC 4010-04	1/2" NPT Stacking Filter- Regulator- Lubricator* (105 SCFM)	\$103.79
	AC 4010-04D	1/2" NPT Stacking Filter- Regulator- Lubricator* with Auto Drain (105 SCFM)	\$135.39
	AC 4010-04M	1/2" NPT Stacking Filter- Regulator- Lubricator* with Metal Bowl (105 SCFM)	\$134.21
	AC 4010-04DM	1/2" NPT Stacking Filter- Regulator- Lubricator* with Auto Drain & Metal Bowl (105 SCFM)	\$151.97
	AC 4010-06	3/4" NPT Stacking Filter- Regulator- Lubricator* (105 SCFM)	\$118.63
	AC 4010-06D	3/4" NPT Stacking Filter- Regulator- Lubricator* with Auto Drain (105 SCFM)	\$150.22
	AC 4010-06M	3/4" NPT Stacking Filter- Regulator- Lubricator* with Metal Bowl (105 SCFM)	\$143.72
	AC 4010-06DM	3/4" NPT Stacking Filter- Regulator- Lubricator* with Auto Drain & Metal Bowl (105 SCFM)	\$150.48
AC 5010-10	1" NPT Stacking Filter- Regulator- Lubricator* (140 SCFM)	\$148.29	
AC 5010-10D	1" NPT Stacking Filter- Regulator- Lubricator* with Auto Drain (140 SCFM)	\$179.88	
AC 5010-10M	1" NPT Stacking Filter- Regulator- Lubricator* with Metal Bowl (140 SCFM)	\$178.70	
AC 5010-10DM	1" NPT Stacking Filter- Regulator- Lubricator* with Auto Drain & Metal Bowl (140 SCFM)	\$233.84	





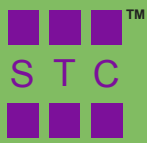



	Part No.	Description (* Includes Bracket & Gauge)	List Price
 <p>Includes Bracket & Gauge</p>	AR1000-M5	M5/10-32 Regulator* (4 SCFM)	\$22.77
	AR2000-01	1/8" NPT Regulator* (19 SCFM)	\$23.55
	AR2000-02	1/4" NPT Regulator* (19 SCFM)	\$23.55
	AR2500-02	1/4" NPT Regulator* (50 SCFM)	\$33.64
	AR3000-02	1/4" NPT Regulator* (88 SCFM)	\$36.49
	AR3000-03	3/8" NPT Regulator* (88 SCFM)	\$36.49
	AR4000-03	3/8" NPT Regulator* (210 SCFM)	\$48.66
	AR4000-04	1/2" NPT Regulator* (210 SCFM)	\$48.66
	AR4000-06	3/4" NPT Regulator* (210 SCFM)	\$56.26
	AR5000-10	1" NPT Regulator* (280 SCFM)	\$60.86
	AF1000-M5	M5 Filter (4 SCFM)	\$13.68
	AF2000-01	1/8" NPT Filter (26 SCFM)	\$14.10
	AF2000-01D	1/8" NPT Filter with Auto Drain (26 SCFM)	\$33.53
	AF2000-01M	1/8" NPT Filter with Metal Bowl (26 SCFM)	\$20.98
	AF2000-01DM	1/8" NPT Filter with Auto Drain & Metal Bowl (26 SCFM)	\$35.35
	AF2000-02	1/4" NPT Filter (26 SCFM)	\$14.10
	AF2000-02D	1/4" NPT Filter with Auto Drain (26 SCFM)	\$33.53
	AF2000-02DM	1/4" NPT Filter Auto Drain & Metal Bowl (26 SCFM)	\$36.89
 <p>With Metal Bowl and Sight Glass</p>  <p>Polycarbonate Bowl with Metal Shield</p>	AF3000-02	1/4" NPT Filter (70 SCFM)	\$21.28
	AF3000-02D	1/4" NPT Filter with Auto Drain (70 SCFM)	\$46.64
	AF3000-02M	1/4" NPT Filter with Metal Bowl (70 SCFM)	\$28.88
	AF3000-02DM	1/4" NPT Filter Auto Drain & Metal Bowl (70 SCFM)	\$50.69
	AF3000-03	3/8" NPT Filter (70 SCFM)	\$21.28
	AF3000-03D	3/8" NPT Filter with Auto Drain (70 SCFM)	\$46.64
	AF3000-03M	3/8" NPT Filter with Metal Bowl (70 SCFM)	\$28.88
	AF3000-03DM	3/8" NPT Filter Auto Drain & Metal Bowl (70 SCFM)	\$50.69
	AF4000-03	3/8" NPT Filter (140 SCFM)	\$29.66
	AF4000-03D	3/8" NPT Filter with Auto Drain (140 SCFM)	\$55.01
	AF4000-03M	3/8" NPT Filter with Metal Bowl (140 SCFM)	\$37.26
	AF4000-03DM	3/8" NPT Filter Auto Drain & Metal Bowl (140 SCFM)	\$62.61
	AF4000-04	1/2" NPT Filter (140 SCFM)	\$29.66
	AF4000-04D	1/2" NPT Filter with Auto Drain (140 SCFM)	\$55.01
	AF4000-04M	1/2" NPT Filter with Metal Bowl (140 SCFM)	\$37.26
	AF4000-04DM	1/2" NPT Filter Auto Drain & Metal Bowl (140 SCFM)	\$62.61
	AF4000-06	3/4" NPT Filter (210 SCFM)	\$33.08
	AF4000-06D	3/4" NPT Filter with Auto Drain (210 SCFM)	\$64.68
	AF4000-06M	3/4" NPT Filter with Metal Bowl (210 SCFM)	\$40.68
	AF4000-06DM	3/4" NPT Filter Auto Drain & Metal Bowl (210 SCFM)	\$68.12
AF5000-10	1" NPT Filter (245 SCFM)	\$44.09	
AF5000-10D	1" NPT Filter with Auto Drain (245 SCFM)	\$75.73	
AF5000-10M	1" NPT Filter with Metal Bowl (245 SCFM)	\$51.70	
AF5000-10DM	1" NPT Filter with Auto Drain & Metal Bowl (245 SCFM)	\$83.31	

Air Filter-Regulator-Lubricator List Price

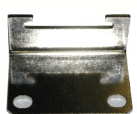

	Part No.	Description (* Includes Bracket & Gauge)	List Price
	AL1000-M5	M5 Lubricator (3 SCFM)	\$13.68
	AL2000-01	1/8" NPT Lubricator (28 SCFM)	\$14.10
	AL2000-01M	1/8" NPT Lubricator with Metal Bowl (28 SCFM)	\$20.64
	AL2000-02	1/4" NPT Lubricator (28 SCFM)	\$14.10
	AL2000-02M	1/4" NPT Lubricator with Metal Bowl (28 SCFM)	\$20.64
	AL3000-02	1/4" NPT Lubricator (60 SCFM)	\$21.28
	AL3000-02M	1/4" NPT Lubricator with Metal Bowl (60 SCFM)	\$28.88
	AL3000-03	3/8" NPT Lubricator (60 SCFM)	\$21.28
	AL3000-03M	3/8" NPT Lubricator with Metal Bowl (60 SCFM)	\$28.88
	AL4000-03	3/8" NPT Lubricator (180 SCFM)	\$29.66
	AL4000-03M	3/8" NPT Lubricator with Metal Bowl (180 SCFM)	\$44.86
	AL4000-04	1/2" NPT Lubricator (180 SCFM)	\$29.66
	AL4000-04M	1/2" NPT Lubricator with Metal Bowl (180 SCFM)	\$44.86
	AL4000-06	3/4" NPT Lubricator (220 SCFM)	\$33.08
	AL4000-06M	3/4" NPT Lubricator with Metal Bowl (220 SCFM)	\$50.03
	AL5000-10	1" NPT Lubricator (245 SCFM)	\$46.76
	AL5000-10M	1" NPT Lubricator with Metal Bowl (245 SCFM)	\$61.98
	 <p>Includes Bracket & Gauge</p>	AW1000-M5	M5 Filter- Regulator* (3 SCFM)
AW2000-01		1/8" NPT Filter- Regulator* (19 SCFM)	\$33.83
AW2000-01D		1/8" NPT Filter- Regulator* with Auto Drain (19 SCFM)	\$51.57
AW2000-01M		1/8" NPT Filter- Regulator* with Metal Bowl (19 SCFM)	\$39.45
AW2000-01DM		1/8" NPT Filter- Regulator* Auto Drain & Metal Bowl (19 SCFM)	\$56.64
AW2000-02		1/4" NPT Filter- Regulator* (19 SCFM)	\$33.83
AW2000-02D		1/4" NPT Filter- Regulator* with Auto Drain (19 SCFM)	\$51.57
AW2000-02M		1/4" NPT Filter- Regulator* with Metal Bowl (19 SCFM)	\$39.45
AW2000-02DM		1/4" NPT Filter- Regulator* Auto Drain & Metal Bowl (19 SCFM)	\$56.64
 <p>Includes Bracket & Gauge</p>		AW3000-02	1/4" NPT Filter- Regulator* (70 SCFM)
	AW3000-02D	1/4" NPT Filter- Regulator* with Auto Drain (70 SCFM)	\$70.97
	AW3000-02M	1/4" NPT Filter- Regulator* with Metal Bowl (70 SCFM)	\$53.23
	AW3000-02DM	1/4" NPT Filter- Regulator* Auto Drain & Metal Bowl (70 SCFM)	\$78.57
	AW3000-03	3/8" NPT Filter- Regulator* (70 SCFM)	\$45.62
	AW3000-03D	3/8" NPT Filter- Regulator* with Auto Drain (70 SCFM)	\$70.97
	AW3000-03M	3/8" NPT Filter- Regulator* with Metal Bowl (70 SCFM)	\$53.23
	AW3000-03DM	3/8" NPT Filter- Regulator* Auto Drain & Metal Bowl (70 SCFM)	\$78.57
	AW4000-03	3/8" NPT Filter- Regulator* (140 SCFM)	\$68.44
	AW4000-03D	3/8" NPT Filter- Regulator* with Auto Drain (140 SCFM)	\$100.03
	AW4000-03M	3/8" NPT Filter- Regulator* with Metal Bowl (140 SCFM)	\$83.64
	AW4000-03DM	3/8" NPT Filter- Regulator* Auto Drain & Metal Bowl (140 SCFM)	\$115.21
	AW4000-04	1/2" NPT Filter- Regulator* (140 SCFM)	\$68.44
	AW4000-04D	1/2" NPT Filter- Regulator* with Auto Drain (140 SCFM)	\$100.03
	AW4000-04M	1/2" NPT Filter- Regulator* with Metal Bowl (140 SCFM)	\$83.64
	AW4000-04DM	1/2" NPT Filter- Regulator* Auto Drain & Metal Bowl (140 SCFM)	\$115.21
	AW4000-06	3/4" NPT Filter- Regulator* (160 SCFM)	\$79.85
	AW4000-06D	3/4" NPT Filter- Regulator* with Auto Drain (160 SCFM)	\$111.44
	AW4000-06M	3/4" NPT Filter- Regulator* with Metal Bowl (160 SCFM)	\$95.05
	AW4000-06DM	3/4" NPT Filter- Regulator* Auto Drain & Metal Bowl (160 SCFM)	\$126.63
	AW5000-10	1" NPT Filter- Regulator* (195 SCFM)	\$95.07
	AW5000-10D	1" NPT Filter- Regulator* with Auto Drain (195 SCFM)	\$126.66
	AW5000-10M	1" NPT Filter- Regulator* with Metal Bowl (195 SCFM)	\$110.29
AW5000-10DM	1" NPT Filter- Regulator* Auto Drain & Metal Bowl (195 SCFM)	\$141.86	

FRL Mounting Hardware List Price

	Part No.	Description	List Price
	Y20	Spacer for AC2000/AC2010	\$4.42
	Y30	Spacer for AC3000/AC3010	\$7.38
	Y40	Spacer for AC4000-04/AC4010-04	\$8.83
	Y50	Spacer for AC4000-06/AC4000-06	\$8.83
	Y60	Spacer for AC5000/AC5010	\$9.21
	Y20L	L-Type Spacer Bracket for AC2000	\$4.81
	Y30L	L-Type Spacer Bracket for AC3000	\$7.38
	Y40L	L-Type Spacer Bracket for AC4000-04	\$8.83
	Y50L	L-Type Spacer Bracket for AC4000-06	\$8.83
	Y60L	L-Type Spacer Bracket for AC5000	\$9.21
	Y20T	T-Type Spacer Bracket for AC2010	\$5.16
	Y30T	T-Type Spacer Bracket for AC3010	\$8.83
	Y40T	T-Type Spacer Bracket for AC4010-04	\$9.58
	Y50T	T-Type Spacer Bracket for AC4010-06	\$10.32
	Y60T	T-Type Spacer Bracket for AC5010	\$14.76
	Y21-N01	Spacer with 1/8 NPT Port for AC2000	\$7.38
	Y21-N02	Spacer with 1/4 NPT Port for AC2000	\$7.38
	Y31-N01	Spacer with 1/8 NPT Port for AC3000	\$11.06
	Y31-N02	Spacer with 1/4 NPT Port for AC3000	\$11.06
	Y41-N02	Spacer with 1/4 NPT Port for AC4000	\$13.26
	Y41-N03	Spacer with 3/8 NPT Port for AC4000	\$14.47
	Y61-N03	Spacer with 3/8 NPT Port for AC5000	\$18.42
	Y61-N04	Spacer with 1/2 NPT Port for AC5000	\$23.04
	B110L	L-Bracket for AC1000	\$4.42
	B210L	L-Bracket for AC2000	\$7.37
	B310L	L-Bracket for AC3000	\$8.83
	B410L	L-Bracket for AC4000	\$9.21
	B510L	L-Bracket for AC4000-06	\$9.21
	B110T	T-Bracket for AC1010	\$5.16
	B210T	T-Bracket for AC2010	\$8.10
	B310T	T-Bracket for AC3010	\$9.58
	B410T	T-Bracket for AC4010	\$10.31
	B510T	T-Bracket for AC4010-06	\$14.74
	B120	Bracket for AR/AW1000	\$2.22
	B220	Bracket for AR/AW2000	\$2.40
	B320	Bracket for AR/AW3000	\$2.95
	B420	Bracket for AR/AW4000-5000	\$3.69
	B240	Bracket for AF/AL2000	\$2.40
	B340	Bracket for AF/AL3000	\$3.24
	B440	Bracket for AF/AL4000-04	\$3.69
	B540	Bracket for AF/AL4000-06	\$4.42
	B640	Bracket for AF/AL5000	\$5.90
	GE-1-160-00	1" Dia. 1/16" R 0-160 PSI back mount pressure gauge for AR1000 series FRL	\$7.10
	GE-1 1/2-30-01	1 1/2" Dia. 1/8" NPT 0-30 PSI back mount pressure gauge for 2000 series FRL	\$7.10
	GE-1 1/2-60-01	1 1/2" Dia. 1/8" NPT 0-60 PSI back mount pressure gauge for 2000 series FRL	\$7.10
	GE-1 1/2-160-01	1 1/2" Dia. 1/8" NPT 0-160 PSI back mount pressure gauge for 2000 series FRL	\$7.10
	GP-1 1/2-160-01	1 1/2" Dia. 1/8" NPT 0-160 PSI panel mount pressure gauge for 2000 series FRL	\$8.26
	GE-2-30-02	2" Dia. 1/4" NPT 0-30 PSI back mount pressure gauge for 3000-5000 series FRL	\$7.61
	GE-2-60-02	2" Dia. 1/4" NPT 0-60 PSI back mount pressure gauge for 3000-5000 series FRL	\$7.61
	GE-2-160-02	2" Dia. 1/4" NPT 0-160 PSI back mount pressure gauge for 3000-5000 series FRL	\$8.41
	GP-2-160-02	2" Dia. 1/4" NPT 0-160 PSI panel mount pressure gauge	\$8.76
	GA-1 1/2-60-01	1.5" Dia. 1/8" NPT 0-60 PSI SS housing back mount glycerin filled	\$12.16
GA-1 1/2-160-01	1.5" Dia. 1/8" NPT 0-160 PSI SS housing back mount glycerin filled	\$12.16	
	VHS2000-01	1/8" NPT Relieving Shut-off /Lockout Valve for 2000-01 Series FRL	\$25.64
	VHS2000-02	1/4" NPT Relieving Shut-off /Lockout Valve for 2000-02 Series FRL	\$25.64
	VHS3000-02	1/4" NPT Relieving Shut-off /Lockout Valve for 3000-02 Series FRL	\$32.68
	VHS3000-03	3/8" NPT Relieving Shut-off /Lockout Valve for 3000-03 Series FRL	\$32.68
	VHS4000-03	3/8" NPT Relieving Shut-off /Lockout Valve for 4000-03 Series FRL	\$48.69
	VHS4000-04	1/2" NPT Relieving Shut-off /Lockout Valve for 4000-04 Series FRL	\$48.69
	VHS4000-06	1/2" NPT Relieving Shut-off /Lockout Valve for 4000-06 Series FRL	\$99.70
	VHS5000-10	1/2" NPT Relieving Shut-off /Lockout Valve for 5000 Series FRL	\$99.70

Filter-Regulator-Lubricator Air Flow Charts

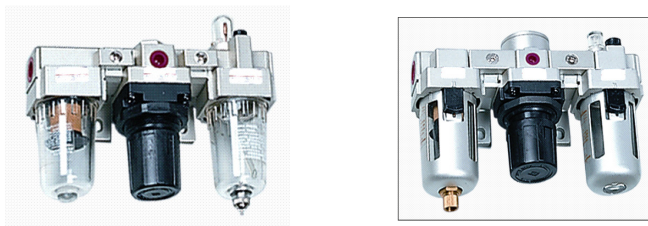

Filter Regulator Lubricator Selection:

1. Determine flow rate requirements.
2. Determine required set point pressure and allowable pressure drop.
3. Locate the FRL graph with set point pressure that provides the flow rate with acceptable pressure drop.

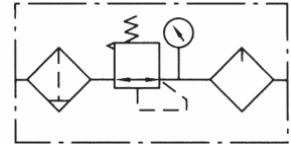

AC1000 Series Filter Regulator Lubricator
Flow Rate VS Set Point Pressure
Supply Pressure 100 PSI

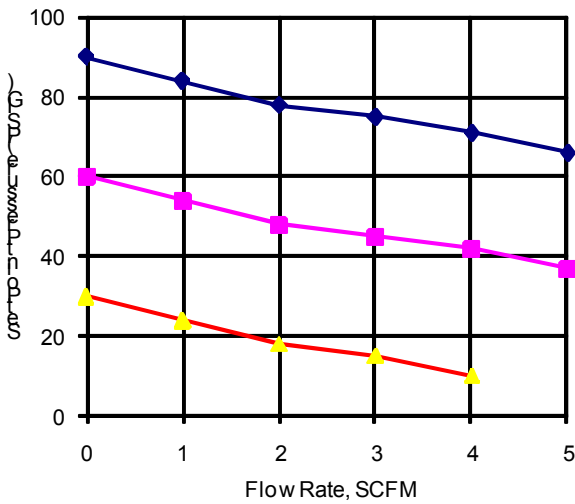

AC2000 Series Filter Regulator Lubricator
Flow Rate VS Set Point Pressure
Supply Pressure 100 PSI

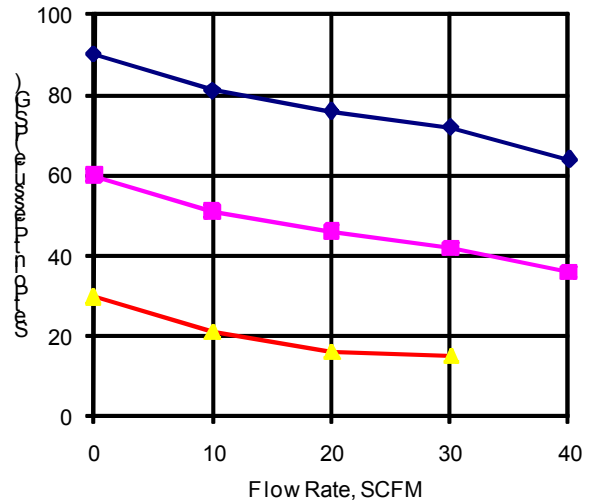

AC3000 Series Filter Regulator Lubricator
Flow Rate VS Set Point Pressure
Supply Pressure 100 PSI

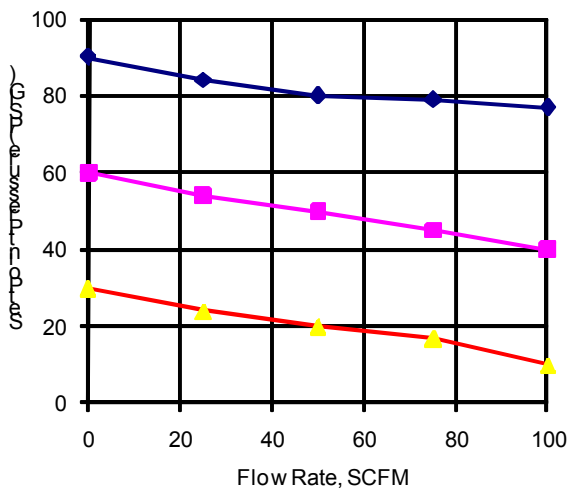

AC4000 Series Filter Regulator Lubricator
Flow Rate VS Set Point Pressure
Supply Pressure 100 PSI

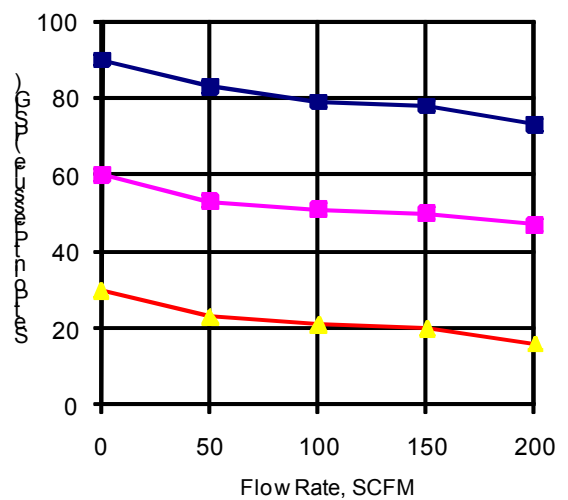

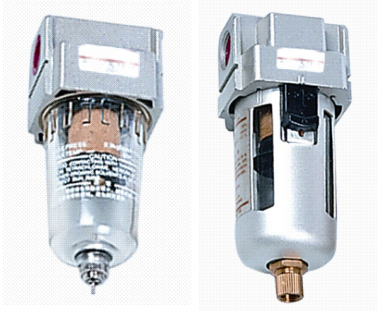

Filter Selection:

1. Determine flow rate requirements.
2. Determine required set point pressure and allowable pressure drop.
3. Locate the FRL graph with set point pressure that provides the flow rate with acceptable pressure drop.

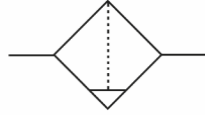

AF1000 Series Filter
Flow Rate VS Pressure Drop
@ 30, 60, 90 PSI Supply Pressure

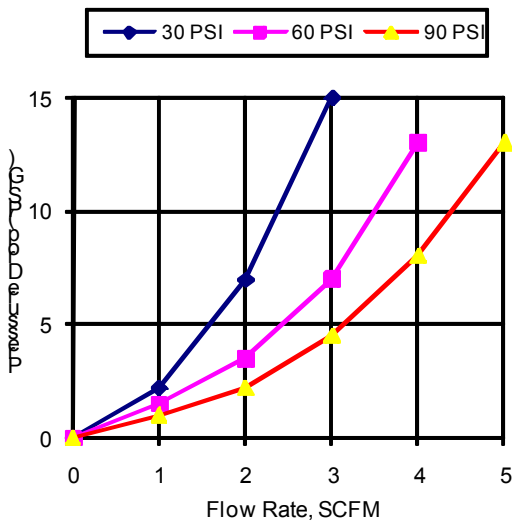

AF2000 Series Filter
Flow Rate VS Pressure Drop
@ 30, 60, 90 PSI Supply Pressure

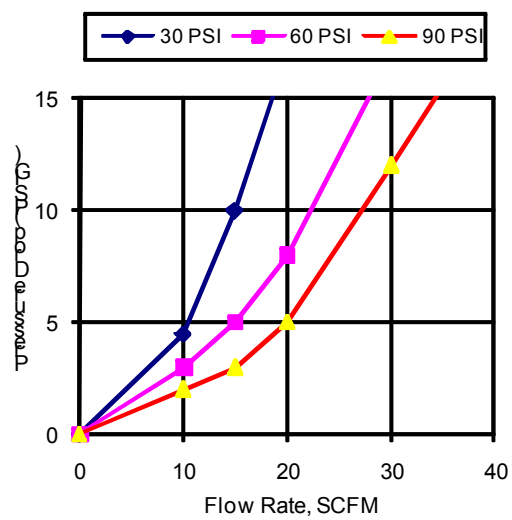

AF3000 Series Filter
Flow Rate VS Pressure Drop
@ 30, 60, 90 PSI Supply Pressure

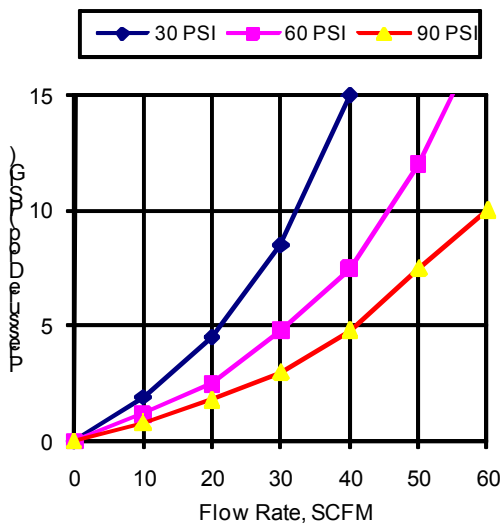

AF4000 Series Filter
Flow Rate VS Pressure Drop
@ 30, 60, 90 PSI Supply Pressure

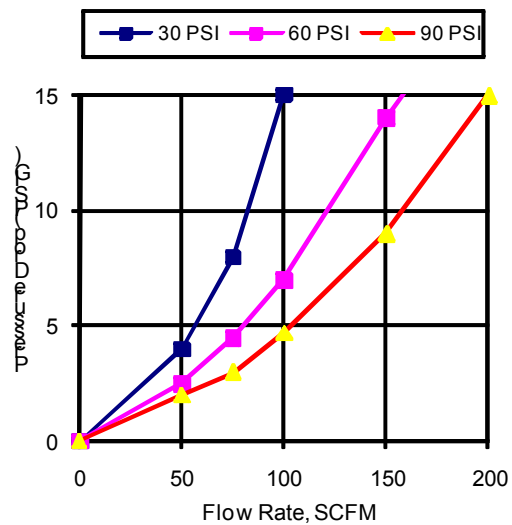

Air Regulator Flow Charts



Regulator Selection:

1. Determine flow rate requirements.
2. Determine required set point pressure and allowable pressure drop.
3. Locate the FRL graph with set point pressure that provides the flow rate with acceptable pressure drop.

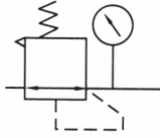

AR1000 Series Pressure Regulator
Flow Rate VS Set Point Pressure
Supply Pressure 100 PSI

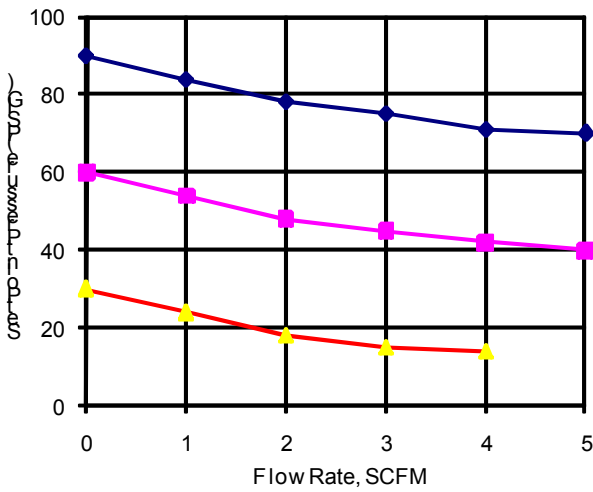

AR2000 Series Pressure Regulator
Flow Rate VS Set Point Pressure
Supply Pressure 100 PSI

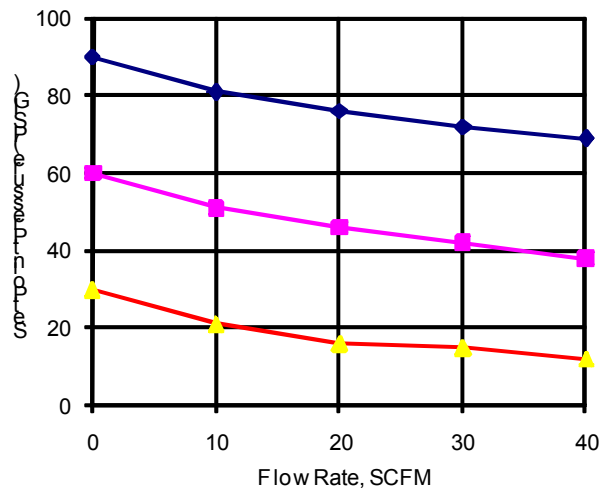

AR3000 Series Pressure Regulator
Flow Rate VS Set Point Pressure
Supply Pressure 100 PSI

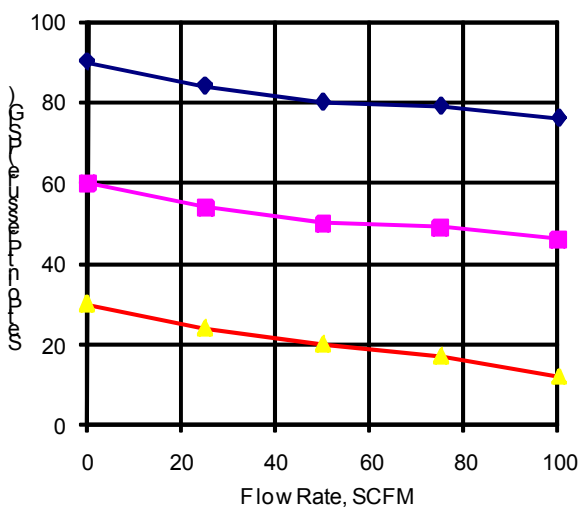

AR4000 Series Pressure Regulator
Flow Rate VS Set Point Pressure
Supply Pressure 100 PSI

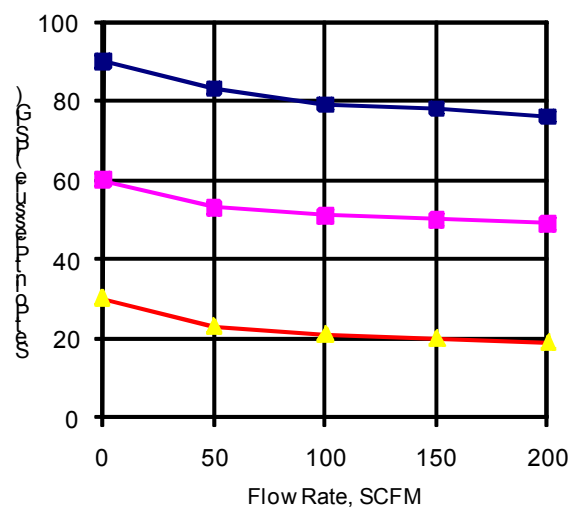

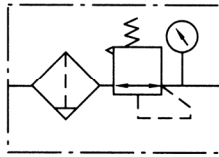

Filter Regulator Selection:

1. Determine flow rate requirements.
2. Determine required set point pressure and allowable pressure drop.
3. Locate the FRL graph with set point pressure that provides the flow rate with acceptable pressure drop.

A W1000 Series Filter Regulator
Flow Rate VS Set Point Pressure
Supply Pressure 100 PSI

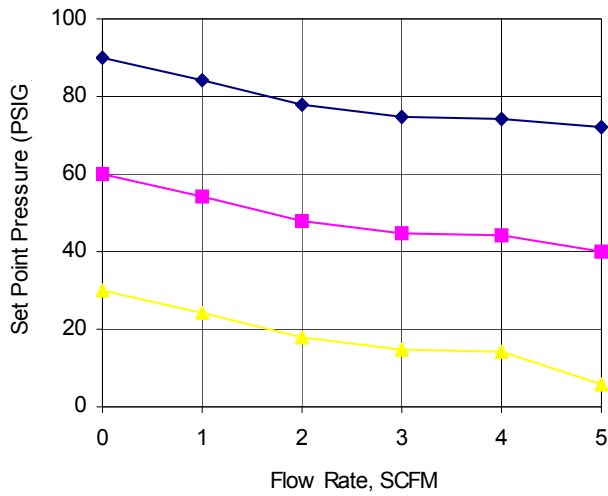

AW2000 Series Filter Regulator
Flow Rate VS Set Point Pressure
Supply Pressure 100 PSI

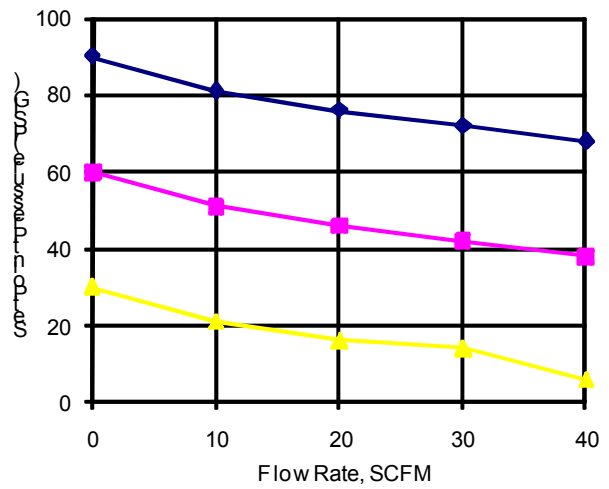

AW3000 Series Filter Regulator
Flow Rate VS Set Point Pressure
Supply Pressure 100 PSI

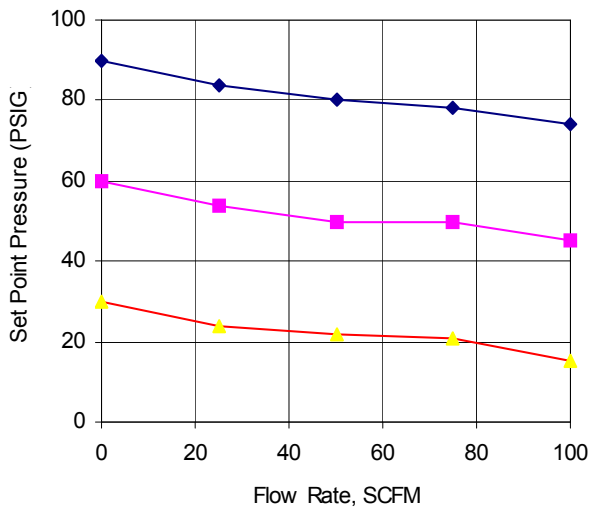

AW4000 Series Filter Regulator
Flow Rate VS Set Point Pressure
Supply Pressure 100 PSI

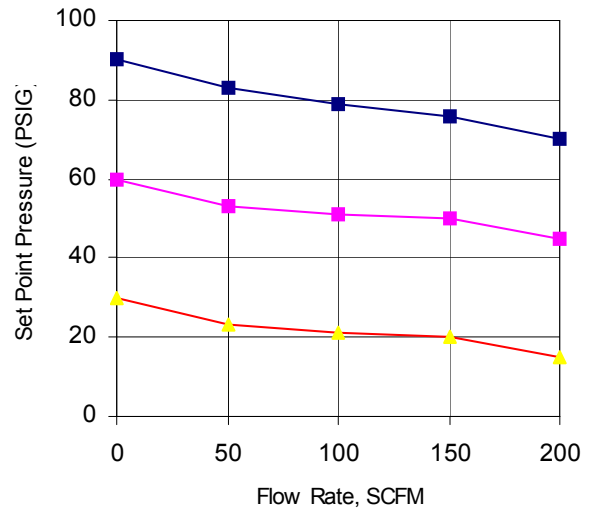

Air Filter Regulator Lubricator Flow Charts



Filter Regulator Lubricator Selection:

1. Determine flow rate requirements.
2. Determine required set point pressure and allowable pressure drop.
3. Locate the FRL graph with set point pressure that provides the flow rate with acceptable pressure drop.

AC5000 Series Filter Regulator Lubricator
Flow Rate VS Set Point Pressure
Supply Pressure 100 PSI

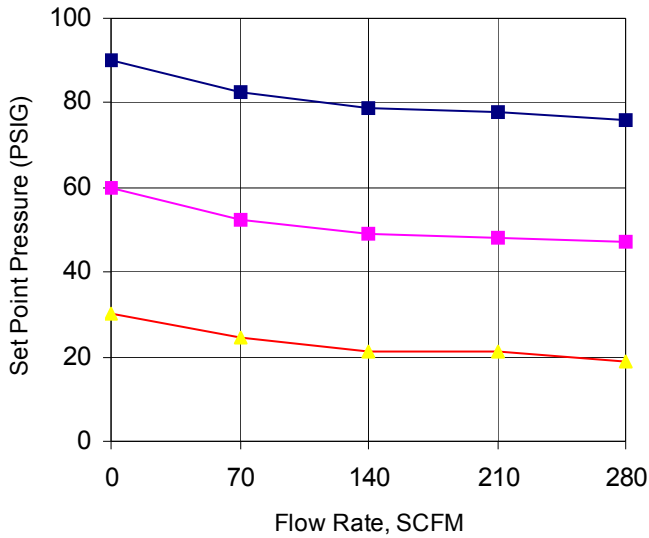

AW5000 Series Filter Regulator
Flow Rate VS Set Point Pressure
Supply Pressure 100 PSI

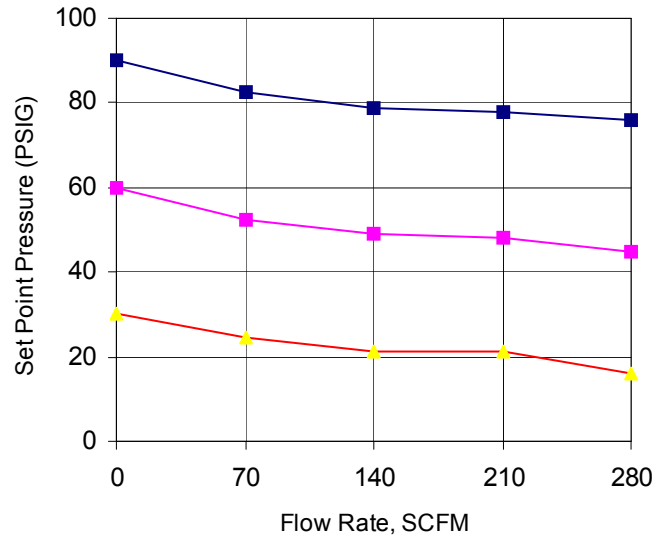

AF5000 Series Filter
Flow Rate VS Pressure Drop
@ 30, 60, 90 PSI Supply Pressure

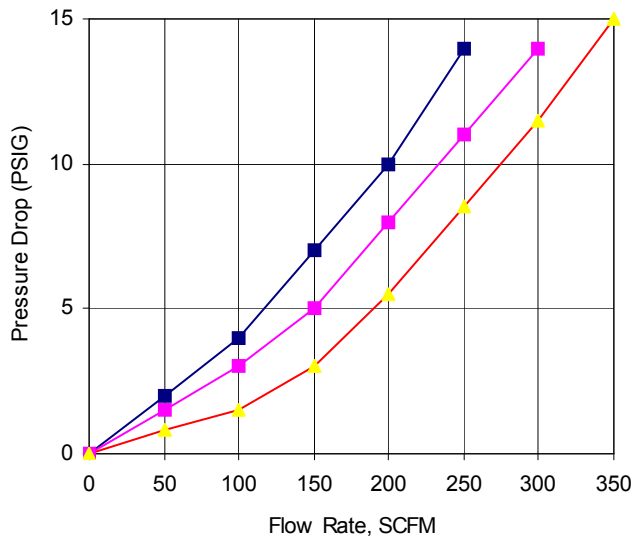

AR5000 Series Pressure Regulator
Flow Rate VS Set Point Pressure
Supply Pressure 100 PSI

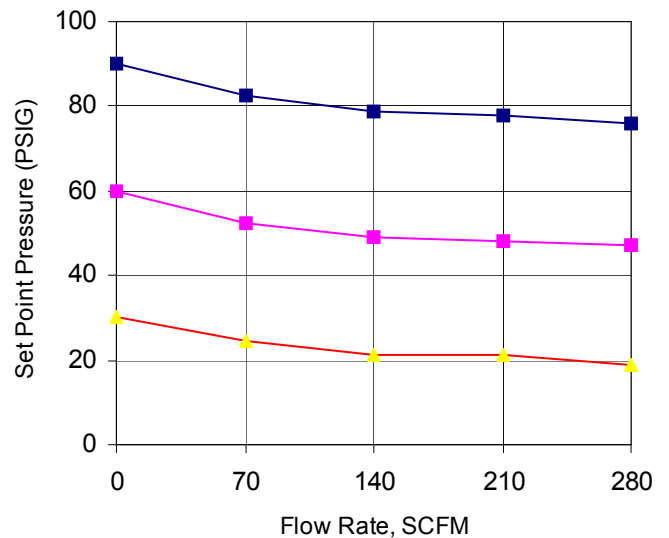

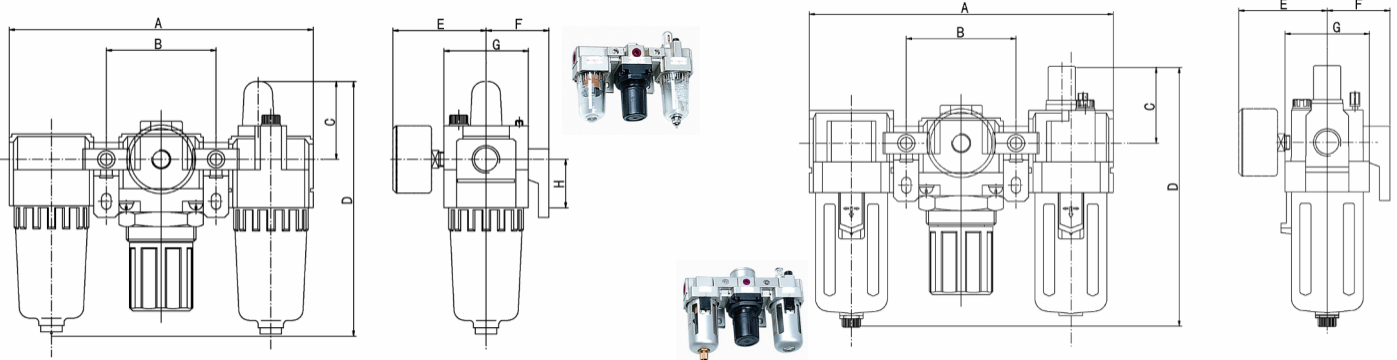

Model	Flow Rate (lpm/scfm)	Port	Gauge Port	A (mm/in)	B (mm/in)	C (mm/in)	D (mm/in)	E (mm/in)	F (mm/in)	G (mm/in)	H (mm/in)	Bracket	Weight (kg/lb)	Gauge
AC1000-00	90	10-32 (M5)	1/16 Rc	91	33	25.5	84.5	26	25	25	20	Y10L	0.26	GE-1-160-00
	3			3.58	1.30	1.00	3.33	1.02	0.98	0.98	0.79		0.57	
AC2000-01	500	1/8 NPT	1/8 NPT	140	50	38	125	56.8	30	40	24	Y20L	0.74	GE-1 1/2-160-01
AC2000-02	18	1/4 NPT		5.51	1.97	1.50	4.92	2.24	1.18	1.57	0.94		1.63	
AC3000-02	2000	1/4 NPT	1/8 NPT	181	64	38	156.5	60.8	41	53	35	Y30L	1.18	GE-1 1/2-160-01
AC3000-03	70	3/8 NPT		7.13	2.52	1.50	6.16	2.39	1.69	2.09	1.38		2.60	
AC4000-03	4000	3/8 NPT	1/4 NPT	238	84	41	191.5	65.5	50	70	40	Y40L	2.14	GE-2-160-02
AC4000-04	140	1/2 NPT		9.37	3.31	1.61	7.54	2.58	1.97	2.76	1.57		4.71	
AC4000-06	4500	3/4 NPT	1/4 NPT	253	89	41	193	69.5	50	70	40	Y50L	2.47	GE-2-160-02
	160			9.96	3.50	1.61	7.60	2.74	1.97	2.76	1.57		5.43	
AC5000-06	5000	3/4 NPT	1/4 NPT	300	105	48	271.5	75.5	69.8	90	50	Y60L	3.82	GE-2-160-02
AC5000-10	180	1 NPT		11.81	4.13	1.89	10.69	2.97	2.75	3.54	1.97		8.40	

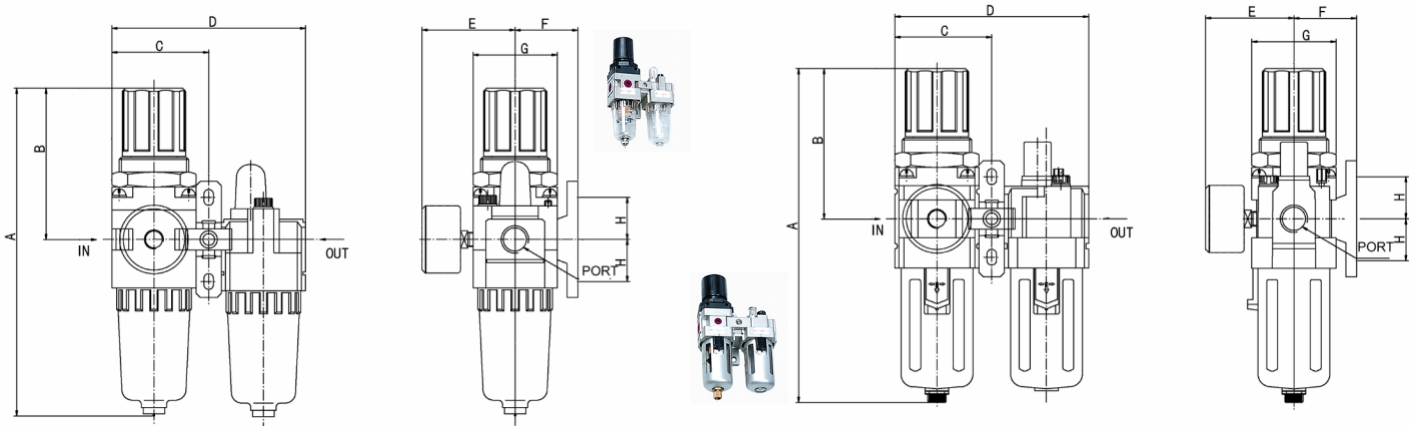

Model	Flow Rate (lpm/scfm)	Port	Gauge Port	A (mm/in)	B (mm/in)	C (mm/in)	D (mm/in)	E (mm/in)	F (mm/in)	G (mm/in)	H (mm/in)	Bracket	Weight (kg/lb)	Gauge
AC1010-00	90	10-32 (M5)	1/16 Rc	109.5	50.5	29	58	26	25	25	20	Y10T	0.22	GE-1-160-00
	3			4.31	1.99	1.14	2.28	1.02	0.98	0.98	0.79		0.48	
AC2010-01	500	1/8 NPT	1/8 NPT	164.5	78	45	90	56.8	30	40	24	Y20T	0.66	GE-1 1/2-160-01
AC2010-02	18	1/4 NPT		6.48	3.07	1.77	3.54	2.24	1.18	1.57	0.94		1.45	
AC3010-02	1700	1/4 NPT	1/8 NPT	211	92.5	58.5	117	60.8	41	53	35	Y30T	0.98	GE-1 1/2-160-01
AC3010-03	60	3/8 NPT		8.31	3.64	2.30	4.61	2.39	1.61	2.09	1.38		2.16	
AC4010-03	3000	3/8 NPT	1/4 NPT	262	112	77	154	65.5	50	70	40	Y40T	1.93	GE-2-160-02
AC4010-04	105	1/2 NPT		10.31	4.41	3.03	6.06	2.58	1.97	2.76	1.57		4.25	
AC4010-06	3000	3/4 NPT	1/4 NPT	267	114	82	164	69.5	50	70	40	Y50T	1.99	GE-2-160-02
	105			10.51	4.49	3.23	6.46	2.74	1.97	2.76	1.57		4.38	
AC5010-06	4000	3/4 NPT	1/4 NPT	338	116	97.5	195	75.5	69.8	90	50	Y60T	3.2	GE-2-160-02
AC5010-10	140	1 NPT		13.31	4.57	3.84	7.68	2.97	2.75	3.54	1.97		7.04	

Air Filter Regulator Lubricator Dimensions

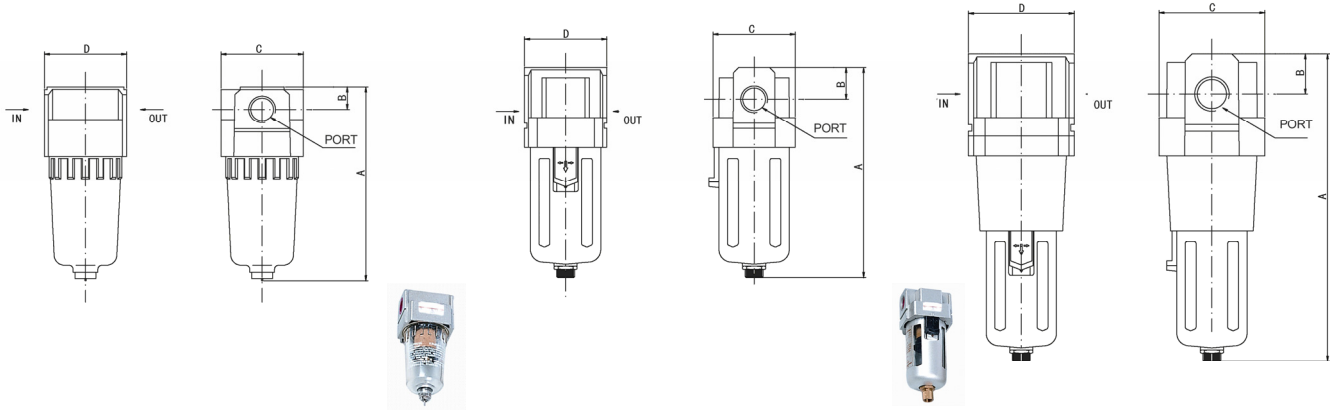

Model	Flow Rate (lpm/scfm)	Port	A (mm/in)	B (mm/in)	C (mm/in)	D (mm/in)	Bracket/Screw	Weight (kg/lb)
AF1000-00	110	10-32 (M5)	66	7	25		B140	0.07
	4		2.60	0.28	0.98	0.00		0.15
AF2000-01	750	1/8 NPT	97.5	11	40	40	B240/M4x8	0.19
AF2000-02	26	1/4 NPT	3.84	0.43	1.57	1.57		0.42
AF3000-02	2000	1/4 NPT	132.5	14	53	53	B340/M4x8	0.29
AF3000-03	70	3/8 NPT	5.22	0.55	2.09	2.09		0.64
AF4000-03	4000	3/8 NPT	168.5	18	70	70	B440/M5x10	0.55
AF4000-04	140	1/2 NPT	6.63	0.71	2.76	2.76		1.21
AF4000-06	6000	3/4 NPT	172.5	20	70	70	B540/M5x10	0.58
	210		6.79	0.79	2.76	2.76		1.28
AF5000-06	7000	3/4 NPT	247.5	24	90	90	B640/M6x10	1.08
AF5000-10	245	1 NPT	9.74	0.94	3.54	3.54		2.38

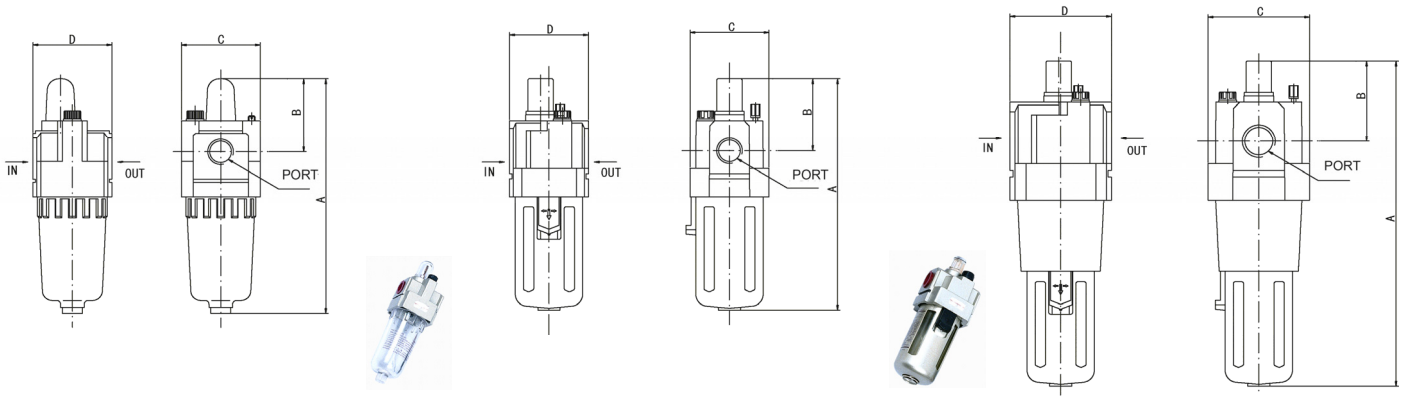

Model	Flow Rate (lpm/scfm)	Port	A (mm/in)	B (mm/in)	C (mm/in)	D (mm/in)	Bracket/Screw	Weight (kg/lb)
AL1000-00	95	10-32 (M5)	81.5	25.5	25		B140	0.07
	3		3.21	1.00	0.98			0.15
AL2000-01	800	1/8 NPT	122	38	40	40	B240/M4x8	0.22
AL2000-02	28	1/4 NPT	4.80	1.50	1.57	1.57		0.48
AL3000-02	1700	1/4 NPT	142	38	53	53	B340/M4x8	0.3
AL3000-03	60	3/8 NPT	5.59	1.50	2.09	2.09		0.66
AL4000-03	5000	3/8 NPT	177	41	70	70	B440/M5x10	0.56
AL4000-04	180	1/2 NPT	6.97	1.61	2.76	2.76		1.23
AL4000-06	6300	3/4 NPT	177	39	70	70	B540/M5x10	0.58
	220		6.97	1.54	2.76	2.76		1.28
AL5000-06	7000	3/4 NPT	254	45	90	90	B640/M6x10	1.08
AL5000-10	245	1 NPT	10.00	1.77	3.54	3.54		2.38

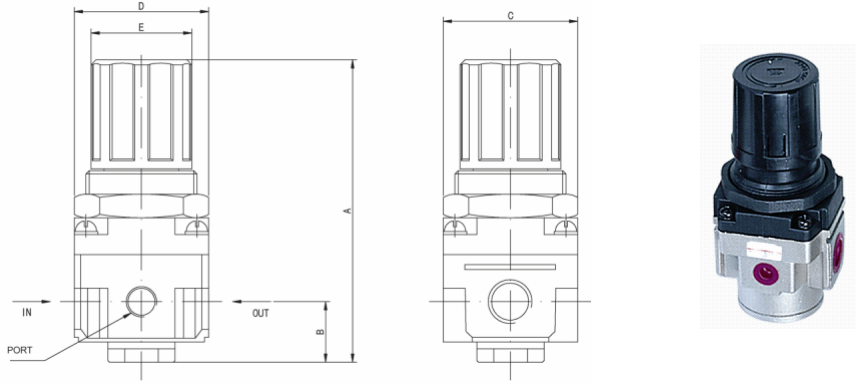

Model	Flow Rate (lpm/scfm)	Port	Gauge Port	A (mm/in)	B (mm/in)	C (mm/in)	D (mm/in)	E (mm/in)	Panel Cut Hole (mm/in)	Bracket	Weight (kg/lb)	Gauge
AR1000-00	100	10-32 (M5)	1/16 Rc	61.5	11	25	25	20	20.5	B120	0.08	GE-1-160-00
	4			2.42	0.43	0.98	0.98	0.79	0.81		0.18	
AR2000-01	550	1/8 NPT	1/8 NPT	95	17	40	40	34	33.5	B220	0.27	GE-1 1/2-160-01
AR2000-02	19	1/4 NPT		3.74	0.67	1.57	1.57	1.34	1.32		0.59	
AR2500-02	2000	1/4 NPT		102.5	25	48	53	34	33.5			
AR2500-03	70	3/8 NPT		4.04	0.98	18.9	2.09	1.34	1.32			
AR3000-02	2500	1/4 NPT	1/8 NPT	127.5	35	53	53	40	42.5	B320	0.41	GE-1 1/2-160-01
AR3000-03	88	3/8 NPT	5.02	1.38	2.09	2.09	1.57	1.67	0.90			
AR4000-03	6000	3/8 NPT	1/4 NPT	149.5	37.5	70	70	54	52.5	B420	0.84	GE-2-160-02
AR4000-04	210	1/2 NPT		5.89	1.48	2.76	2.76	2.13	2.07		1.85	
AR4000-06	6000	3/4 NPT	1/4 NPT	154	40.5	70	75	54	52.5	B420	0.84	GE-2-160-02
	210			6.06	1.59	2.76	2.95	2.13	2.07		1.85	
AR5000-06	8000	3/4 NPT	1/4 NPT	168	48	90	90	54	52.5	B420	1.19	GE-2-160-02
AR5000-10	280	1 NPT		6.61	1.89	3.54	3.54	2.13	2.07		2.62	

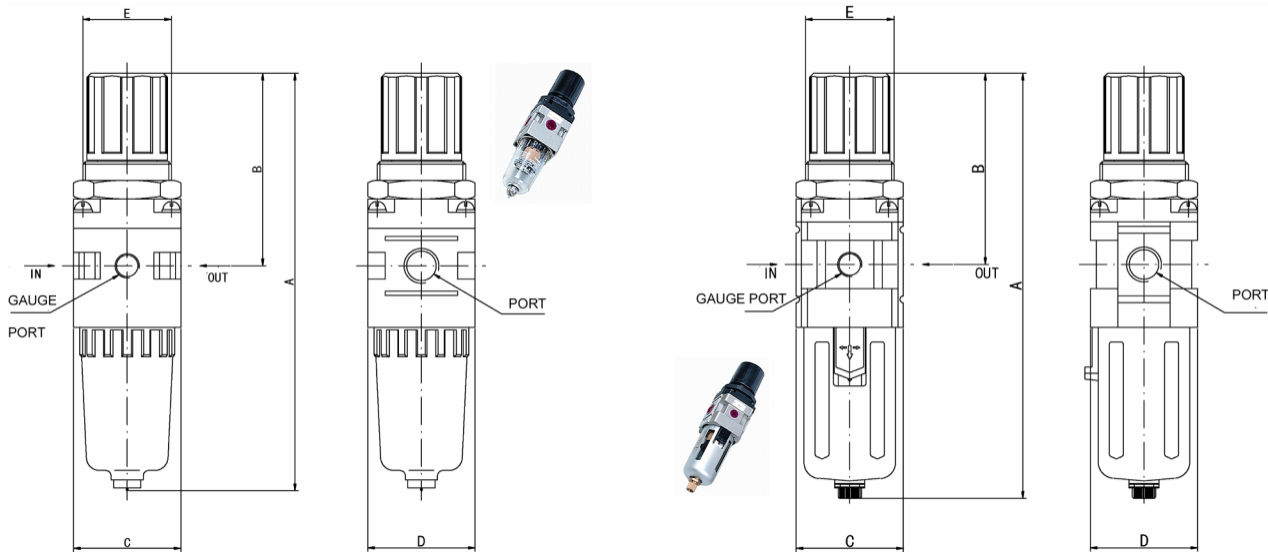

Model	Flow Rate (lpm/scfm)	Port	Gauge Port	A (mm/in)	B (mm/in)	C (mm/in)	D (mm/in)	E (mm/in)	Panel Cut Hole (mm/in)	Bracket	Weight (kg/lb)	Gauge
AW1000-00	90	10-32 (M5)	1/16 Rc	109.5	50.5	25	28	20	20.5	B120	0.09	GE-1-160-00
	3			4.31	1.99	0.98	1.10	1.10	0.81		0.20	
AW2000-01	550	1/8 NPT	1/8 NPT	164.5	78	40	40	34	33.5	B220	0.36	GE-1 1/2-160-01
AW2000-02	19	1/4 NPT		6.48	3.07	1.57	1.57	1.34	1.32		0.79	
AW3000-02	2000	1/4 NPT	1/8 NPT	211	92.5	53	53	40	33.5	B320	0.56	GE-1 1/2-160-01
AW3000-03	70	3/8 NPT		8.31	3.64	2.09	2.09	1.57	1.32		1.23	
AW4000-03	4000	3/8 NPT	1/4 NPT	262	112	70	70	54	42.5	B420	1.15	GE-2-160-02
AW4000-04	140	1/2 NPT		10.31	4.41	2.76	2.76	2.13	1.67		2.53	
AW4000-06	4500	3/4 NPT	1/4 NPT	267	114	70	75	54	42.5	B520	1.21	GE-2-160-02
	160			10.51	4.49	2.76	2.95	2.13	1.67		2.66	
AW5000-06	5500	3/4 NPT	1/4 NPT	338	116	90	90	54	42.5	B620	1.7	GE-2-160-02
AW5000-10	195	1 NPT		13.31	4.57	3.54	3.54	2.13	1.67		3.74	

Air Filter Regulator Lubricator Dimensions

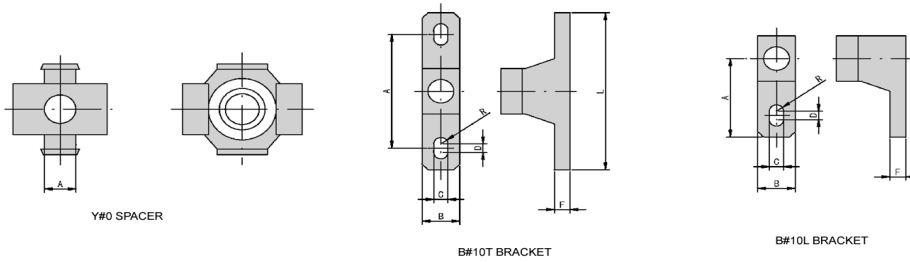
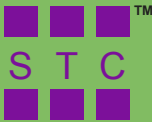

Spacer

T Bracket

L Bracket

L Bracket	L Spacer Bracket	For	T Bracket	T Spacer Bracket	For	A	B	C	D	E	F	G	H	R	L
B110L	Y10L	AC1000	B110T	Y10T	AC1010	20	12	4.5	3	2.5	5	8	40	2.25	27
B210L	Y20L	AC2000	B210T	Y20T	AC2010	24	15	5.5	3	30	5	10	48	2.75	33
B310L	Y30L	AC3000	B310T	Y30T	AC3010	35	16	7	4	41	7	11	70	3.5	45
B410L	Y40L	AC4000	B410T	Y40T	AC4010	40	22	9	4	50	7	14	80	4.5	50
B510L	Y50L	AC4000-06	B510T	Y50T	AC4010-06	40	22	9	4	50	7	14	80	4.5	50
B610L	Y60L	AC5000	B610T	Y60T	AC5010	50	23	12	4	69.8	10.5	15	100	6	63

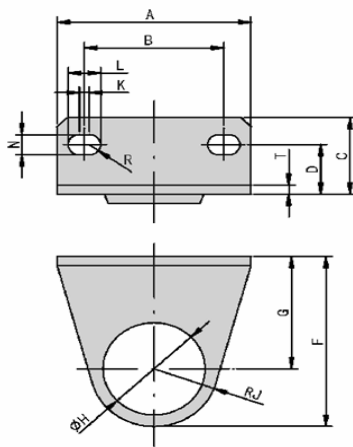

B#20 -Bracket for AR & AW

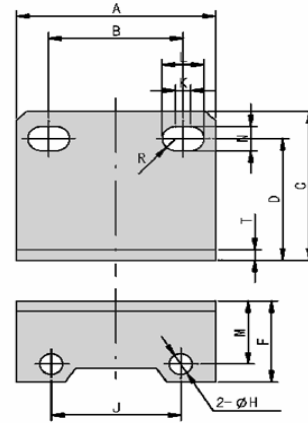

B#40 Bracket for AF/AL

in (MM)	A	B	C	D	F	G	H	J	K	L	M	N	R	t	Mounting Screw	For
B120	40	28	17	11	37.8	25	20.5	12.3	2	6.5		4.5	2.25	2		AR/AW1000
B220	55	34	35	19	50	30	33.5	20	10	5.4		5.4	2.7	2.3		AR/AW2000-2500
B320	53	40	21.5	14	64	39	42.5	25	1.5	6.5		6.5	3.25	2.3		AR/AW3000
B420	70	54	27	18	79.2	49.2	52.5	30	2	8.5		8.5	4.25	2.3		AR/AW4000-5000
B240	40	27	33	27	18		4.5	26	3	8.4	14	5.4	2.7	2.3	M4X8	AF/AL2000
B340	53	40	39	32	22.5		4.5	35	1.5	8	19	6.5	3.25	2.3	M4X8	AF/AL3000
B440	70	54	47	38	31.5		5.5	47	2	10.5	20	8.5	4.25	2.3	M5X10	AF/AL4000-04
B540	70	54	47	38	31.5		5.5	47	2	10.5	20	8.5	4.25	2.3	M5X10	AF/AL4000-06
B640	90	66	64	52	43		6.5	60	2	13	29	11	5.5	3.2	M6X10	AF/AL5000

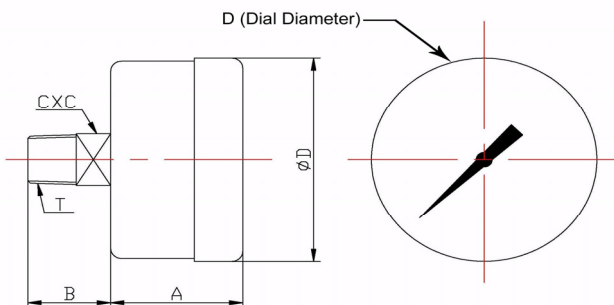

Pressure Gauge Part No.	For	(in/MM)				
		T Port Size	A	B	D	
GE-1-160-00	AR1000	R1/16 (PT)	0.6/15.3	0.4/10	0.47/12	1.0/25.4
GE-1 1/2-160-01	AR2000-3000	1/8 NPT	0.93/25.8	0.67/17.0	0.43/11	1.6/42
GE-2-160-02	AR4000-5000	1/4 NPT	0.97/24.8	0.77/19.7	0.54/14	2.1/52.4

These FRL components are of modular design with joiner clamps. The joiner clamps allow easy connection and disconnection of FRL components for simple installation and maintenance.

Interchangeable with SMC - NAC SERIES FRL

MODEL	AC1000-00	AC2000-XX	AC3000-XX	AC4000-XX	AC4000-06	AC5000-XX
Air Flow Rate* SCFM (LPM)	3 (90)	18 (500)	70 (2000)	140 (4000)	160 (4500)	180 (5000)
Stacking Regulator-Filter-Lubricator	AC1010-00	AC2010-XX	AC3010-XX	AC4010-XX	AC4010-06	AC5010-XX
Air Flow Rate* SCFM (LPM)	3 (90)	18 (500)	60 (1700)	105 (3000)	105 (3000)	140 (4000)
Stacking Regulator-Filter	AW1000-00	AW2000-XX	AW3000-XX	AW4000-XX	AW4000-06	AW5000-XX
Air Flow Rate* SCFM (LPM)	3 (90)	19 (550)	70 (2000)	140 (4000)	160 (4500)	195 (5500)
Regulators	AR1000-00	AR2000-XX	AR3000-XX	AR4000-XX	AR4000-06	AR5000-XX
Air Flow Rate* SCFM (LPM)	4 (100)	19 (550)	88 (2500)	210 (6000)	210 (6000)	280 (8000)
Filters	AF1000-00	AF2000-XX	AF3000-XX	AF4000-XX	AF4000-06	AF5000-XX
Air Flow Rate* SCFM (LPM)	4 (110)	26 (750)	70 (2000)	140 (4000)	210 (6000)	245 (7000)
Lubricators	AL1000-00	AL2000-XX	AL3000-XX	AL4000-XX	AL4000-06	AL5000-XX
Air Flow Rate* SCFM (LPM)	3 (90)	28 (800)	60 (1700)	180 (5000)	220 (6300)	245 (7000)
Port Size	10-32 (M5)	1/8 or 1/4 NPT	1/4 or 3/8 NPT	3/8 or 1/2 NPT	3/4 NPT	3/4 or 1 NPT
Port Size (Pressure Gauge)	1/16 Rc (PT)	1/8 NPT	1/8 NPT	1/4 NPT	1/4 NPT	1/4 NPT
Regulating Range	7-100 PSI	7-125 PSI (0.5-8.5 kgf/cm ²)				
Max. Operating Pressure	150 PSI (9.9 kgf/cm ²)					
Operating Temperature	40-140°F (5-60°C)					
Filtration	5 micron filter (Option); 25 Micron (Standard Sintered Brass Filter)					
Bowl Material	Polycarbonate (standard) or Aluminum Metal (Option)					
Bowl Guard	N/A		Steel Bowl Guard			
Body Material	Die-Casting Aluminum					
Construction/Regulator	Relieving Type					
Seals	NBR					
Filter Drain	Semi-Auto Differential Drain			Semi-Auto Differential Drain (Standard) or Automatic Drain		
Service	FOR AIR ONLY			FOR AIR ONLY		

*Measured with Supply Air Pressure @100 PSI and Set Point Pressure @ 75 PSI

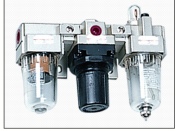

Air Solenoid & Air Pilot Valves

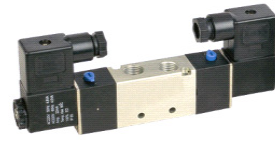
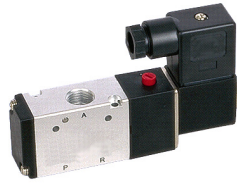
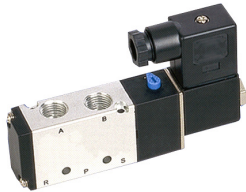
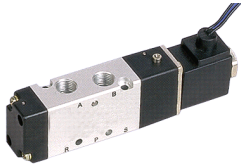

Fine Quality

Precision Engineered



Advanced Design

Excellent Prices

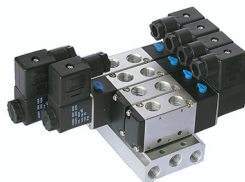

Contents

STC Air Solenoid Valve and Valve Manifold Numbering System.....	F2
STC Air Solenoid Valve List Price.....	F3
Air Pilot Valve List Price.....	F4
Integrated Aluminum Base Mounted Manifolds.....	F4
Air Solenoid Valve and Air Pilot Valve Specifications.....	F4
Air Solenoid and Air Pilot Valves Dimensions.....	F5-8
Manifold Dimensions.....	F8

STC Solenoid Valve Numbering System

Ordering Part No. = (eg. 4V110-1/8-1-D)

4V — 1 — 10 — 1/8 — [] — 1 — D

Model	Valve Size	Solenoid/Position	Port Size (NPT)	Mounting	Voltage	Elec. Terminal
Spool Valves: 3A = 3 way air pilot valve 3V = 3 way solenoid valve 4A = 4 way air pilot valve 4V = 4 way solenoid valve	1 = 0.67 Cv 2 = 0.89 Cv 3 = 1.68 Cv 4 = 2.78 Cv	10 = 1 solenoid 2 position 20 = 2 solenoid 2 position 30C = 2 solenoid 3 position (Closed Center) 30E = 2 solenoid 3 position (Exhausted Center) 30P = 2 solenoid 3 position (Pressure Center)	10-32 1/8 1/4 3/8 1/2	Blank = Standard B = Namur Mounting/ Actuator Mounting	1 = 12 VDC 2 = 24 VDC 2A = 24 VAC 3 = 110 VAC 4 = 220VAC (50/60Hz)	D = DIN G = Grommet E = Explosion Proof U = UL Listed Coil
Direct Acting Valves						
2P025 = 2 way direct acting					1 = 12 VDC 2 = 24 VDC	D = DIN
2V025 = 2 way direct acting				1/8		G = Grommet
3P010 = 3 way direct acting				1/4		E = Explosion Proof
3V010 = 3 way direct acting					2A = 24 VAC 3 = 110 VAC 4 = 220VAC (50/60Hz)	U = UL Listed Coil

STC Valve Manifold Numbering System *

Ordering Part No. = (eg. 4V100M-2)

4V100M — 2 — or — KIT

Model	No. of Stations	Blank Plate
3V100M = Manifold for 3V100 series valves		
3V200M = Manifold for 3V200 series valves		
3V300M = Manifold for 3V300 series valves	2	
3V400M = Manifold for 3V400 series valves	4	
4V100M = Manifold for 4V100 series valves	6	KIT = Include Blanking plate, Gasket & Mounting Hardware
4V200M = Manifold for 4V200 series valves	8	
4V300M = Manifold for 4V300 series valves	16	
4V400M = Manifold for 4V400 series valves		

* gasket and mounting hardware included

Air Solenoid Valve List Price



To Order, Please Specify: 1) Model No., 2) Voltage, & 3) Electrical Entry Options

	Part No.	Price	Voltage & Electrical Connection Options B. Electrical Connection	Port Size (NPT)	# Way/Port/Position/Solenoid	Cv	Power		
	2V025-1/8	\$21.67	Voltage Options: 1 = 12 VDC 2 = 24VDC 2A=24VAC 3 = 110VAC 4 = 220VAC (50/60Hz)	1/8	2/2/2/1 Direct Acting	0.23	3W to 6.5 W		
	2V025-1/4	\$21.67		1/4					
	3V010-1/8	\$21.67		1/8	3/2/2/1 Direct Acting	0.05			
	3V010-1/4	\$21.67		1/4					
	2P025-1/8	\$21.23		1/8	2/2/2/1 Direct Acting	0.23			
	2P025-1/4	\$21.23		1/4					
	2P025-1/8S	\$23.43		1/8	2/2/2/1 Direct Acting for Liquid & DI water	0.23			
	2V1-1/8	\$21.67		1/8	2/2/2/1 Direct Acting	0.23			
	3V1-1/8	\$22.77		1/8	3/2/2/1 Direct Acting	0.05			
	3V110-10/32	\$27.94		B. Terminal Options: D = DIN (with LED indicator & Conduit Terminal) G = Grommet (12" Lead Wire) E = Explosion Proof	10-32	3/3/2/1		0.67	2.5 W
	3V110-1/8	\$27.94			1/8				
	3V210-1/4	\$27.94			1/4				
	3V310-1/4	\$37.64			1/4				
	3V310-3/8	\$37.64			3/8				
	3V410-1/2	\$65.59			1/2				
	3V120-1/8	\$42.78			1/8	3/3/2/2		1.68	3W to 4.8 W
	3V220-1/4	\$42.78			1/4				
	3V320-1/4	\$52.47			1/4				
	3V320-3/8	\$52.47			3/8				
	3V420-1/2	\$91.82			1/2	2.79			
	4V110-10-32	\$29.09	10-32		0.67		2.5 W		
	4V110-1/8	\$29.09	1/8						
	4V210-1/4	\$27.94	1/4, 1/8 (Exh)						
4V310-3/8	\$37.64	3/8, 1/4 (Exh)							
	4V410-1/2	\$65.59	1/2		2.79				
		3V310B-1/4	\$43.35		1/4	3/3/2/1	1.68	3W to 4.8 W	
		3V320B-1/4	\$64.10		1/4				
		4V310B-1/4	\$43.35		1/4				
4V320B-1/4		\$64.10	1/4						
	4V310B-3/8	\$43.35	3/8, 1/4 (Exh)	4/5/2/1	1.68	3W to 4.8 W			
	4V120-1/8	\$42.78	1/8				4/5/2/2	0.67	2.5 W
	4V220-1/4	\$42.78	1/4, 1/8 (Exh)						
	4V320-1/4	\$52.47	1/4						
4V320-3/8	\$52.47	3/8, 1/4 (Exh)							
	4V420-1/2	\$91.82	1/2	2.79					
		4V130C-1/8	\$85.89	1/8	4/5/3/2 Closed Center	0.5	2.5 W		
		4V230C-1/4	\$88.43	1/4, 1/8 (Exh)					
		4V330C-3/8	\$102.09	3/8, 1/4 (Exh)					
4V430C-1/2		\$131.17	1/2						
	4V130P-1/8	\$85.89	1/8	4/5/3/2 Pressure Center	0.5	2.5 W			
	4V230P-1/4	\$88.43	1/4, 1/8 (Exh)						
	4V330P-3/8	\$102.09	3/8, 1/4 (Exh)						
	4V430P-1/2	\$131.17	1/2						
	4V130E-1/8	\$85.89	1/8	4/5/3/2 Exhaust Center	0.5	2.5 W			
	4V230E-1/4	\$88.43	1/4, 1/8 (Exh)						
	4V330E-3/8	\$102.09	3/8, 1/4 (Exh)						
	4V430E-1/2	\$131.17	1/2						

	Part No.	Price	Voltage Options	Electrical Connection Options	Power	Specifications	
	100C	\$8.21	1 = 12 VDC 2 = 24VDC 2A=24VAC	D = DIN (with LED indicator, conduit terminal)	2.5 W	Insulation: F Class IP65; Duty Cycle: 100% ED; CE Certification	
	200C	\$9.13			3-4.8W		
	100C	\$8.21		3 = 110VAC 4 = 220VAC (50/60HZ)	G = Grommet (12" Lead Wire)		2.5 W
	200C	\$9.13					3-4.8W
	200C	\$98.51	1E=12VDC 2E=24VDC 2AE=24VAC 3E=110VAC 4E=220VAC (50/60HZ)	Explosion Proof Coil Option All voltages with 1/2" NPT conduit connection FM Approved CL I; ZONE 1 CL I; DIV.1; GR. A, B, C, D CL II; GR. E, F, G CL III T4 Ta= -20°C...+60°C	Insulation: F Class IP65; Duty Cycle: 100% ED; FM Certification		

To connect DIN coil:

1. Remove the Philip screw from the plastic housing and unplug it from the DIN coil.
2. From the screw opening, use the screw to push the terminal block out of the plastic housing.
3. Note the 1, 2 and ground markings on underside of DIN enclosure.
4. For DC DIN Coil, Connect 1 to Positive, 2 to Negative.
5. For AC DIN Coil, connect 1 to HOT wire, 2 to Neutral wire, and if required connect ground to ground wire.

To connect Grommet coil:

1. For DC Coil, connect one of the two wires to Positive, and the other wire to Negative.
2. For AC Coil, connect one of the two wires to HOT wire, and the other wire to neutral wire.

Air Pilot Valve List Price

	Part No.	Price	Port Size (NPT)	# Ways/Port/ Position/Pilot	Cv		Part No.	Price	Port Size (NPT)	# Ways/Port/ Position/Pilot	Cv		
	3A110-1/8	\$21.67	1/8	3/3/2/1	0.67		4A130C-1/8	\$56.46	1/8	4/5/3/2 Closed Center	0.5		
	3A210-1/4	\$21.67	1/4, 1/8 (Exh)		0.89		4A230C-1/4	\$71.67	1/4, 1/8 (Exh)		0.67		
	3A310-3/8	\$26.24	3/8, 1/4 (Exh)		1.68		4A330C-3/8	\$82.70	3/8, 1/4 (Exh)		1		
	3A410-1/2	\$43.35	1/2		2.79		4A430C-1/2	\$98.34	1/2		1.68		
	3A120-1/8	\$27.38	1/8	3/3/2/2	0.67		4A130P-1/8	\$56.46	1/8	4/5/3/2 Pressure Center	0.5		
	3A220-1/4	\$27.94	1/4, 1/8 (Exh)		0.89		4A230P-1/4	\$71.67	1/4, 1/8 (Exh)		0.67		
	3A320-3/8	\$33.08	3/8, 1/4 (Exh)		1.68		4A330P-3/8	\$82.70	3/8, 1/4 (Exh)		1		
	3A420-1/2	\$56.46	1/2		2.79		4A430P-1/2	\$98.34	1/2		1.68		
	4A110-1/8	\$21.67	1/8	4/5/2/1	0.67			4A130E-1/8	\$56.46	1/8	4/5/3/2 Exhaust Center	0.5	
	4A210-1/4	\$21.67	1/4, 1/8 (Exh)		0.89			4A230E-1/4	\$71.67	1/4, 1/8 (Exh)		0.67	
	4A310-3/8	\$26.24	3/8, 1/4 (Exh)		1.68			4A330E-3/8	\$82.70	3/8, 1/4 (Exh)		1	
	4A410-1/2	\$43.35	1/2		2.79			4A430E-1/2	\$98.34	1/2		1.68	
	4A120-1/8	\$27.38	1/8	4/5/2/2	0.67			4A130E-1/8	\$56.46	1/8	4/5/3/2 Exhaust Center	0.5	
	4A220-1/4	\$27.94	1/4, 1/8 (Exh)		0.89			4A230E-1/4	\$71.67	1/4, 1/8 (Exh)		0.67	
	4A320-3/8	\$33.08	3/8, 1/4 (Exh)		1.68			4A330E-3/8	\$82.70	3/8, 1/4 (Exh)		1	
	4A420-1/2	\$56.46	1/2		2.79			4A430E-1/2	\$98.34	1/2		1.68	
Air Pilot Namur Valves	3A310B-1/4	\$32.82	1/4	3/3/2/1	1.68				4A330E-3/8	\$82.70	3/8, 1/4 (Exh)	4/5/3/2 Exhaust Center	1
	3A320B-1/4	\$39.67	1/4	3/3/2/2	1.68				4A430E-1/2	\$98.34	1/2		1.68
	4A310B-1/4	\$35.02	1/4	4/5/2/1	1.68								
	4A320B-1/4	\$41.86	1/4	4/5/2/2	1.68								

Integrated Aluminum Base Mounted Manifolds*

To Order, Please Specify: 1) Part No., 2) No. of Stations (Order Valve Separately)											
	Part No.	No. of Stations	Price	Description		Part No.	No. of Stations	Price	Description		
	3V-100M-2	2	\$12.68	Integrated Base for Mounting 3V100 or 3A100 series Solenoid Valves		4V-100M-2	2	\$12.68	Integrated Base for Mounting 4V100 or 4A100 series Solenoid Valves		
	3V-100M-4	4	\$25.35			4V-100M-4	4	\$25.35			
	3V-100M-6	6	\$38.02			4V-100M-6	6	\$38.02			
	3V-100M-8	8	\$50.69			4V-100M-8	8	\$50.69			
	3V-100M-16	16	\$101.39			4V-100M-16	16	\$101.39			
	3V-100M-B	blank plate	\$5.57			4V-100M-B	blank plate	\$5.57			
	3V-100M-G	gasket	\$2.47			4V-100M-G	gasket	\$2.47			
	3V-200M-2	2	\$12.68			Integrated Base for Mounting 3V200 or 3A200 series Solenoid Valves	4V-200M-2	2			
	3V-200M-4	4	\$25.35	4V-200M-4			4	\$25.35			
	3V-200M-6	6	\$38.02	4V-200M-6			6	\$38.02			
	3V-200M-8	8	\$50.69	4V-200M-8			8	\$50.69			
	3V-200M-16	16	\$101.39	4V-200M-16			16	\$101.39			
	3V-200M-B	blank plate	\$5.57	4V-200M-B			blank plate	\$5.57			
	3V-200M-G	gasket	\$2.69	4V-200M-G			gasket	\$2.69			
	3V-300M-2	2	\$19.02	Integrated Base for Mounting 3V300 or 3A300 series Solenoid Valves			4V-300M-2	2	\$19.02		
	3V-300M-4	4	\$38.02			4V-300M-4	4	\$38.02			
3V-300M-6	6	\$57.04	4V-300M-6		6	\$57.04					
3V-300M-8	8	\$76.04	4V-300M-8		8	\$76.04					
3V-300M-16	16	\$152.08	4V-300M-16		16	\$152.08					
3V-300M-B	blank plate	\$5.57	4V-300M-B		blank plate	\$5.57					
3V-300M-G	gasket	\$2.91	4V-300M-G		gasket	\$2.91					
3V-400M-2	2	\$31.68	Integrated Base for Mounting 3V400 or 3A400 series Solenoid Valves		4V-400M-2	2	\$31.68	Integrated Base for Mounting 4V400 or 4A400 series Solenoid Valves			
3V-400M-4	4	\$63.37		4V-400M-4	4	\$63.37					
3V-400M-6	6	\$95.05		4V-400M-6	6	\$95.05					
3V-400M-8	8	\$126.74		4V-400M-8	8	\$126.74					
3V-400M-16	16	\$253.46		4V-400M-16	16	\$253.46					
3V-400M-B	blank plate	\$5.57		4V-400M-B	blank plate	\$5.57					
3V-400M-G	gasket	\$3.12		4V-400M-G	gasket	\$3.12					

* Includes mounting hardware and seals

Specifications

Valve Type	3V & 4V 100-400 Series Valves	3A & 4A 100-400 Series Valves	2V025-035 2P025 Series Valves	2V1, 3V1 Series Valves
Port & Mounting	Body Ported, Manifold Mounted	Body Ported, Manifold Mounted	Body Ported, Stacking or Manifold Mounted	Body Ported, Stacking or Manifold Mounted
Action & Motion	Internal Pilot, Spool Design	Air Pilot, Spool Design	Direct Acting	Direct Acting
Operating Pressure	21 to 115 PSI	0 to 115 PSI	Vacuum to 115 PSI	Vacuum to 115 PSI
Coil Insulation & Protection Class	F Class, IP65 (CE Certification)	N/A	F Class, IP65 (CE Certification)	F Class, IP65 (CE Certification)
Coil Duty Cycle	100% ED	100% ED	100% ED	100% ED
Manual Override	Non-Locking: 100 series, Locking: 200 to 400 series	N/A	N/A	Non-Locking
Electrical Connection	D = DIN (with LED indicator, conduit terminal), G = Grommet (12" - 18" Lead Wire)			N/A
Working Medium	40 micron filtered air or inert gas		40 micron filtered air	40 micron filtered air
Maximum Pressure	180 PSI @ 75 Deg. F			
Operating Temperature	14 to 140 Deg. F (-10 to 60 Deg. C)			
Body Material	Aluminum (Engineered Plastic for 2P Series)			
Seal Material	NBR (Buna N)			
Lubrication	Not Required			
Service	Air			

Air Solenoid Valve Dimensions

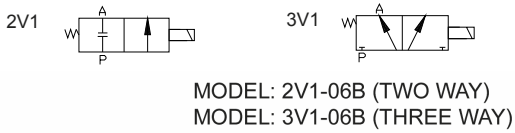
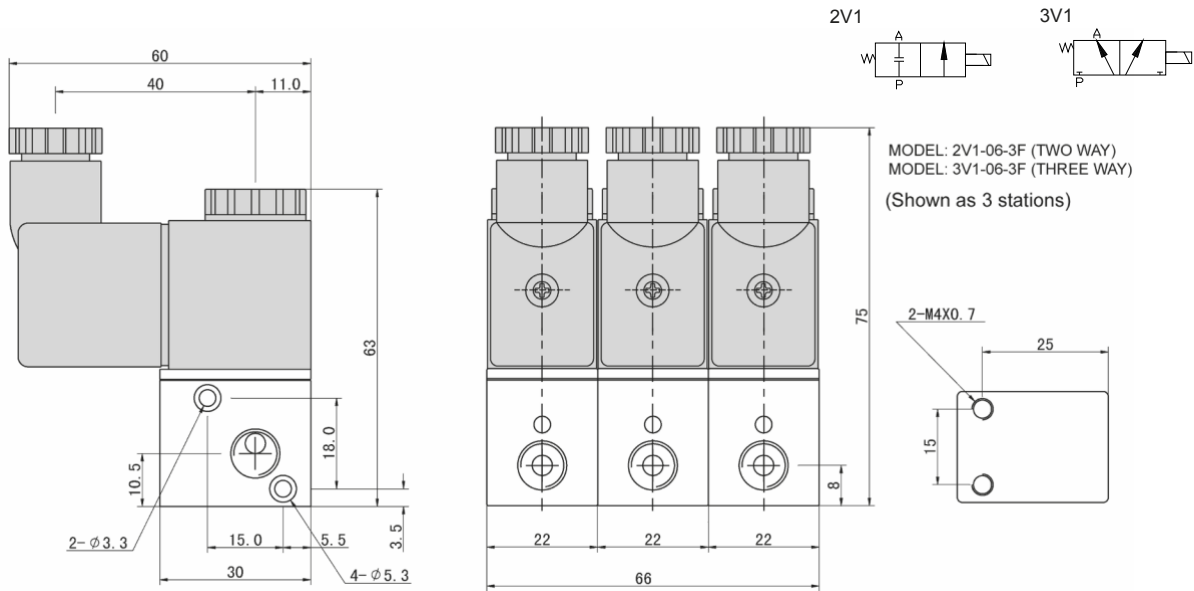
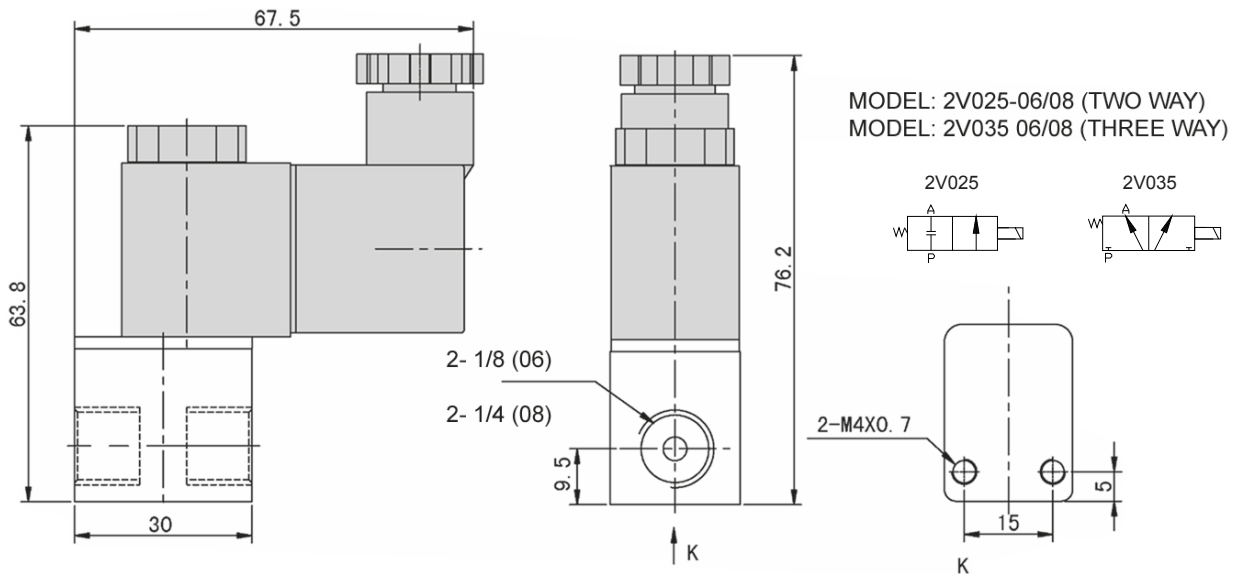

MODEL: 2V1-06B-3F (TWO WAY)
MODEL: 3V1-06B-3F (THREE WAY) Shown as 3 stations

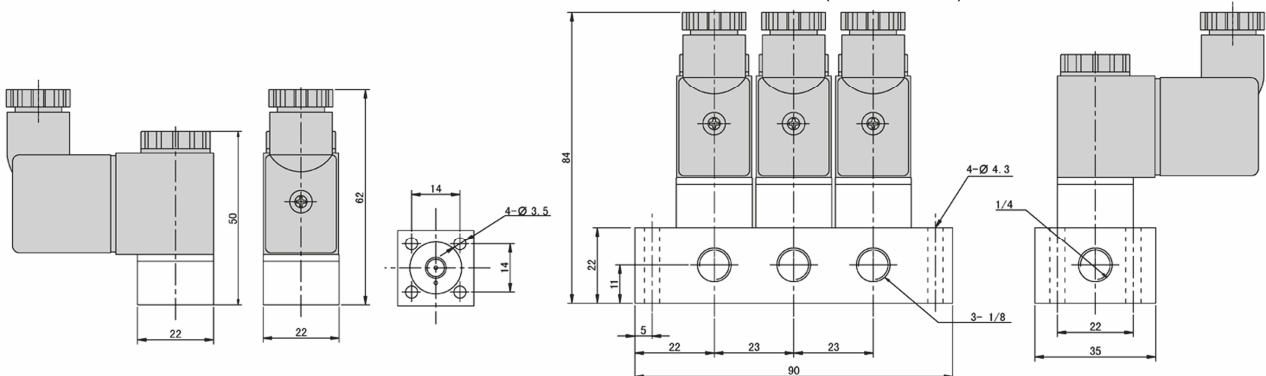

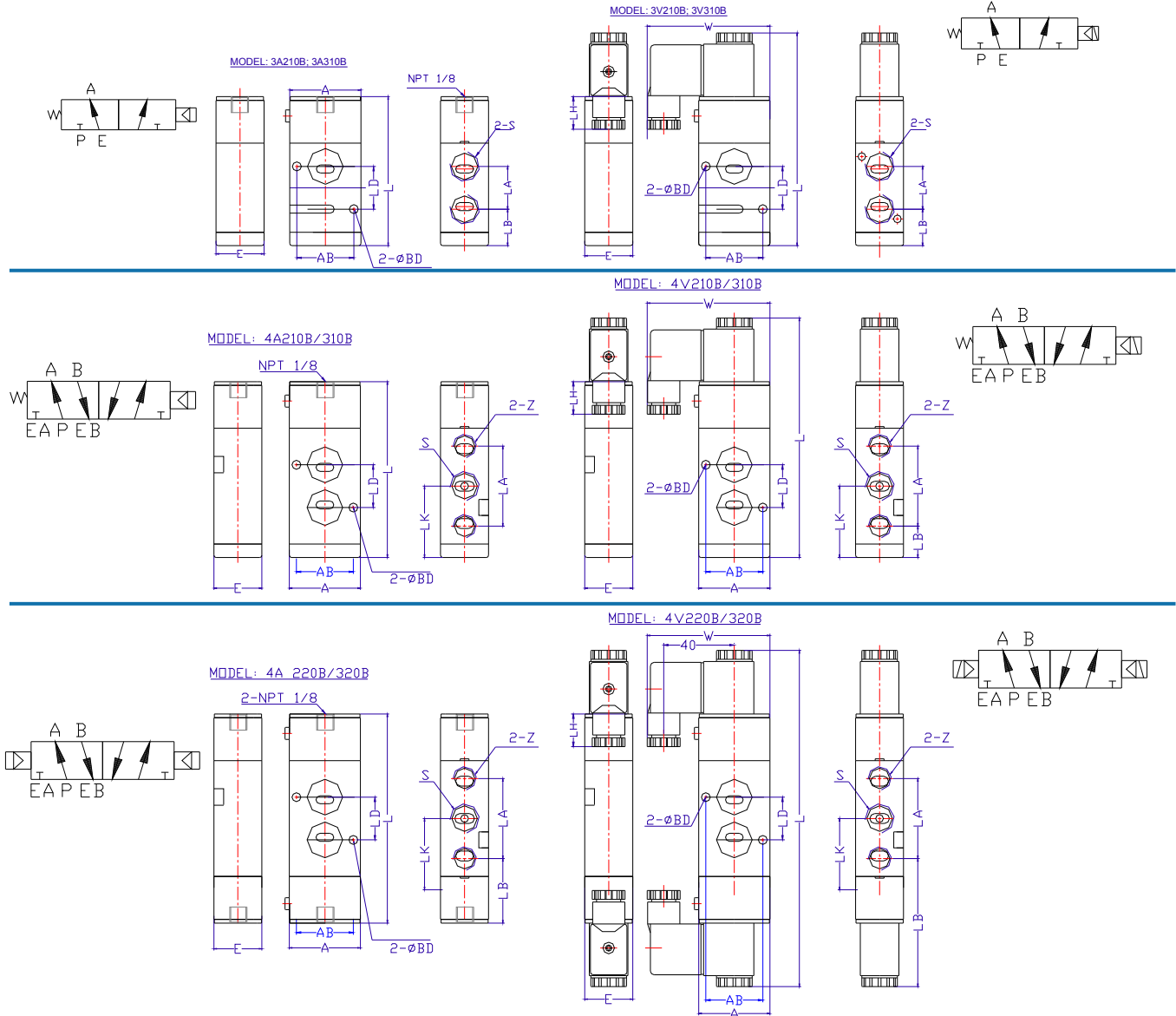

Model	A	E	L	S	W	Z	AB	BD	LA	LB	LD	LH	LK
3A210-1/4B	35	22	77.7	1/4	66.5		29	4.3	18	21			
3A310-1/4B	40	27	80.5	3/8	69		32	5.5	24	20.5			
3A310-3/8B	40	27	80.5	3/8	69		32	5.5	24	20.5			
3V210-1/4B	35	22	111.5	1/4	66.5		29	4.3	18	21		18	
3V310-1/4B	40	27	119.4	1/4	69		32	5.5	24	20.5		18	
3V310-3/8B	40	27	119.4	3/8	69		32	5.5	24	20.5		18	
4A210-1/4B	35	22	77.7	1/4	66.5	1/8	29	4.3	36	13.5	23		31.7
4A310-1/4B	40	27	95.5	1/4	69	1/4	32	5.5	45	17.5	24		40
4A310-3/8B	40	27	95.5	3/8	69	1/4	32	5.5	45	17.5	24		40
4V210-1/4B	35	22	116.5	1/4	66.5	1/8	29	4.3	36	13.5	23	18	32.5
4V310-1/4B	40	27	134.5	1/4	69	1/4	32	5.5	45	17.5	24	18	40
4V310-3/8B	40	27	134.5	3/8	69	1/4	32	5.5	45	17.5	24	18	40
4A220-1/4B	35	22	92	1/4	66.5	1/8	29	4.3	36	28	23		46
4A320-1/4B	40	27	111	1/4	69	1/4	32	5.5	45	33	24		55.5
4A320-3/8B	40	27	111	3/8	69	1/4	32	5.5	45	33	24		55.5
4V220-1/4B	35	22	169.8	1/4	66.5	1/8	29	4.3	36	66.9	23	18	84.9
4V320-1/4B	40	27	188.8	1/4	69	1/4	32	5.5	45	71.9	24	18	94.4
4V320-3/8B	40	27	188.8	3/8	69	1/4	32	5.5	45	71.9	24	18	94.4

Air Solenoid & Air Pilot Valves Dimensions

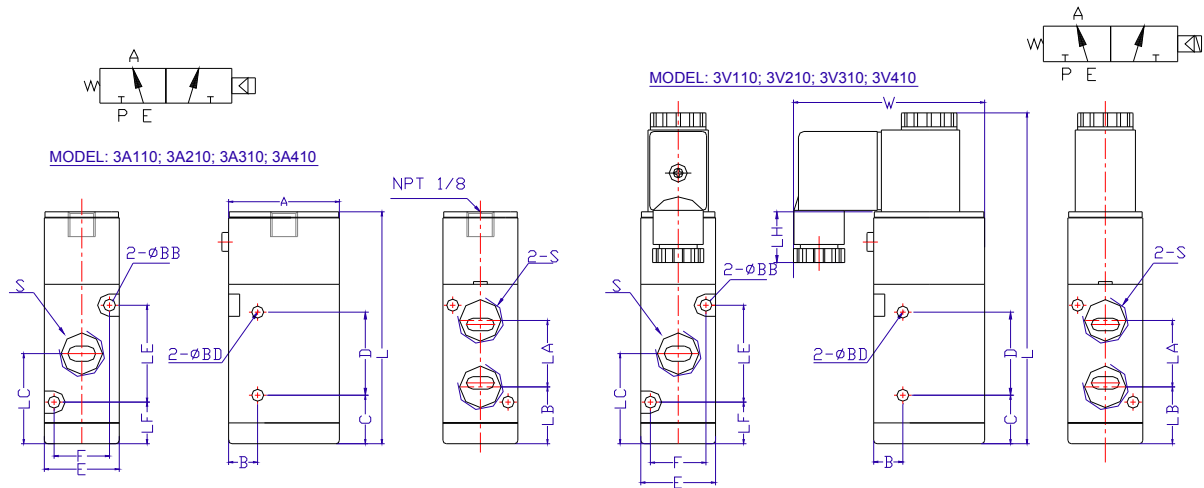

MODEL	A	B	D	E	F	L	S	W	BB	BD	LA	LB	LC	LE	LF	LH
3A110-1/8	27	7.7	21	18.0	13	56.5	1/8	53.5	3.3	3.3	16	14.0	23	19	12.5	
3A210-1/4	35	8.0	25	22.0	17	77.7	1/4	66.5	3.3	4.3	18	21.0	31	33	12.5	
3A310-3/8	40	10.5	30	27.0	20	80.5	3/8	69	4.3	4.3	24	20.5	32.5	35	15	
3A410-1/2	50	13.5	51	34.0	27	96.5	1/2	73.9	4.3	5.5	36	25.5	41.5	44	15.5	
3V110-1/8	27	7.7	21	18.0	13	85.8	1/8	53.5	3.3	3.3	16	14.0	23	19	12.5	10
3V210-1/4	35	8.0	25	22.0	17	111.5	1/4	66.5	3.3	4.3	18	21.0	31	33	12.5	18
3V310-3/8	40	10.5	30	27.0	20	119.4	3/8	69	4.3	4.3	24	20.5	32.5	35	15	18
3V410-1/2	50	13.5	51	34.0	27	137.0	1/2	73.5	4.3	5.5	36	25.5	41.5	44	15.5	18

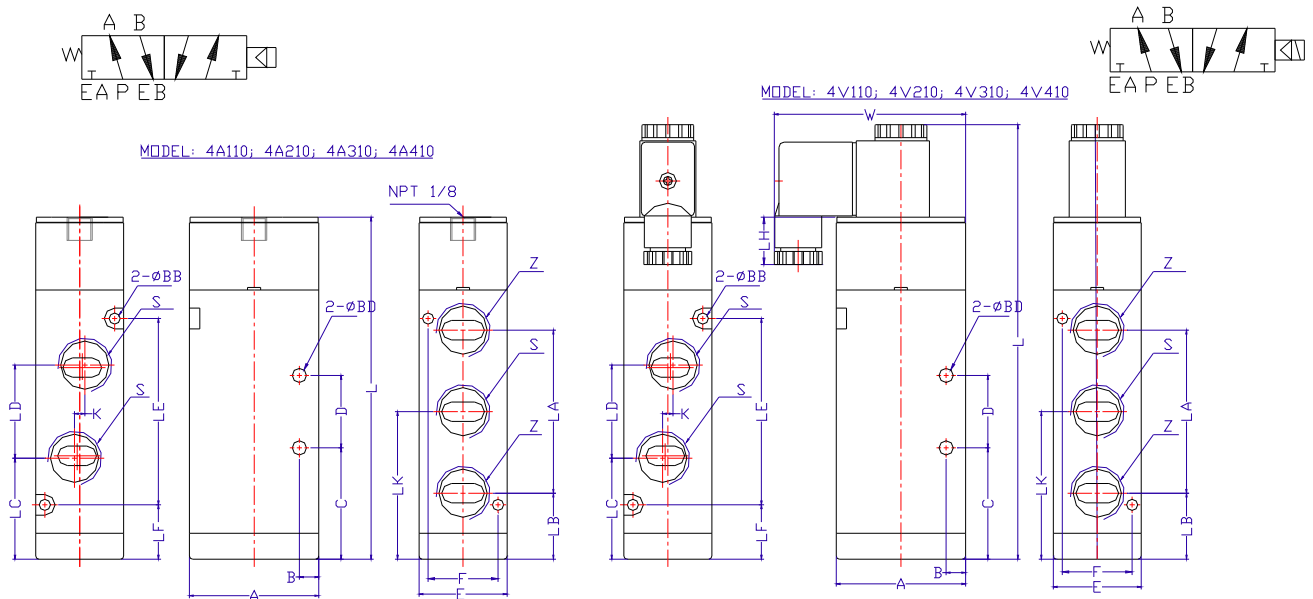

Model	A	B	C	D	E	F	K	L	S	W	Z	BB	BD	LA	LB	LC	LD	LE	LF	LH	LK
4A110-1/8	27	4.0	21.0	14	18	13	3	68.7	1/8	53.5	1/8	3.3	3.3	28	14.2	20.2	16	30	13.0		28.2
4A210-1/4	35	7.0	21.5	20	22	17	3	77.7	1/4	66.5	1/8	3.3	4.3	36	13.5	21.0	21	38	12.5		31.7
4A310-3/8	40	6.5	28.0	24	27	20	4	95.5	3/8	69	1/4	4.3	4.3	45	17.5	28.0	24	50	15.0		40.0
4A410-1/2	50	7.5	43.0	28	34	27	4	128	1/2	73.5	1/2	4.3	5.5	63	25.5	39.0	36	72	21.0		57.0
4V110-1/8	27	4.0	21.0	14	18	13	3	98	1/8	53.5	1/8	3.3	3.3	28	14.0	20.0	16	30	13.0	10	28.0
4V210-1/4	35	7.0	21.5	20	22	17	3	116.5	1/4	66.5	1/8	3.3	4.3	36	13.5	21.0	21	38	12.5	18	32.5
4V310-3/8	40	6.5	28.0	24	27	20	4	134.5	3/8	69	1/4	4.3	4.3	45	17.5	28.0	24	50	15.0	18	40.0
4V410-1/2	50	7.5	43.0	28	34	27	4	167.9	1/2	73.5	1/2	4.3	5.5	63	25.5	39.0	36	72	21.0	18	57.0

Air Solenoid & Air Pilot Valves | Manifolds Dimensions

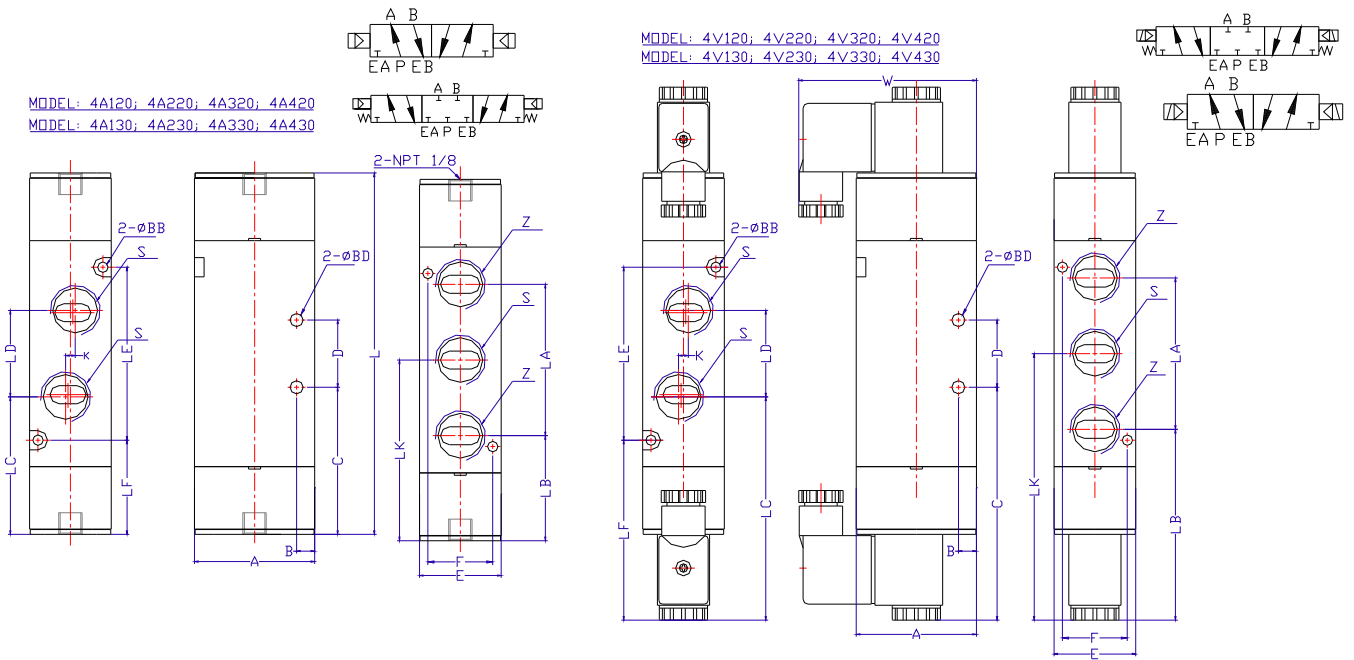

Model	A	B	C	D	E	F	K	L	S	W	Z	BB	BD	LA	LB	LC	LD	LE	LF	LH	LK
4A120-1/8	27	4.0	33.5	14	18	13	3	81	1/8	53.5	1/8	3.3	3.3	28	26.5	32.5	16	30	25.5		40.5
4A220-1/4	35	7.0	36.0	20	22	17	3	92	1/4	66.5	1/8	3.3	4.3	36	28.0	37.0	21	38	27.0		46.0
4A320-3/8	40	6.5	43.5	24	27	20	4	111	3/8	69	1/4	4.3	4.3	45	33.0	43.5	24	50	30.5		55.5
4A420-1/2	50	7.5	51.0	28	34	27	4	128	1/2	73.5	1/2	4.3	5.5	63	39.5	71.0	36	72	35.0		71.0
4V120-1/8	27	4.0	62.8	14	18	13	3	139.5	1/8	53.5	1/8	3.3	3.3	28	56.0	52.0	16	30	54.8	10	69.8
4V220-1/4	35	7.0	74.9	20	22	17	3	169.8	1/4	66.5	1/8	3.3	4.3	36	66.9	74.4	21	38	65.9	18	84.9
4V320-3/8	40	6.5	82.4	24	27	20	4	188.8	3/8	69	1/4	4.3	4.3	45	71.9	82.4	24	50	69.4	18	94.4
4V420-1/2	50	7.5	96.9	28	34	27	4	217.5	1/2	73.5	1/2	4.3	5.5	63	79.4	92.9	36	72	74.9	18	110.9
4A130-1/8	27	4.0	33.5	14	18	13	3	96	1/8	53.5	1/8	3.3	3.3	28	26.5	32.5	16	30	25.5		40.5
4A230-1/4	35	7.0	36.0	20	22	17	3	110	1/4	66.5	1/8	3.3	4.3	36	28.0	37.0	21	38	27.0		46.0
4A330-3/8	40	6.5	43.5	24	27	20	4	130	3/8	69	1/4	4.3	4.3	45	33.0	43.5	24	50	30.5		55.5
4A430-1/2	50	7.5	51.0	28	34	27	4	165	1/2	73.5	1/2	4.3	5.5	63	39.5	71.0	36	72	35.0		71.0
4V130-1/8	27	4.0	62.8	14	18	13	3	154.6	1/8	53.5	1/8	3.3	3.3	28	56.0	52.0	16	30	54.8	10	69.8
4V230-1/4	35	7.0	74.9	20	22	17	3	188.8	1/4	66.5	1/8	3.3	4.3	36	66.9	74.4	21	38	65.9	18	84.9
4V330-3/8	40	6.5	82.4	24	27	20	4	207.8	3/8	69	1/4	4.3	4.3	45	71.9	82.4	24	50	69.4	18	94.4
4V430-1/2	50	7.5	96.9	28	34	27	4	242.8	1/2	73.5	1/2	4.3	5.5	63	79.4	92.9	36	72	74.9	18	110.9

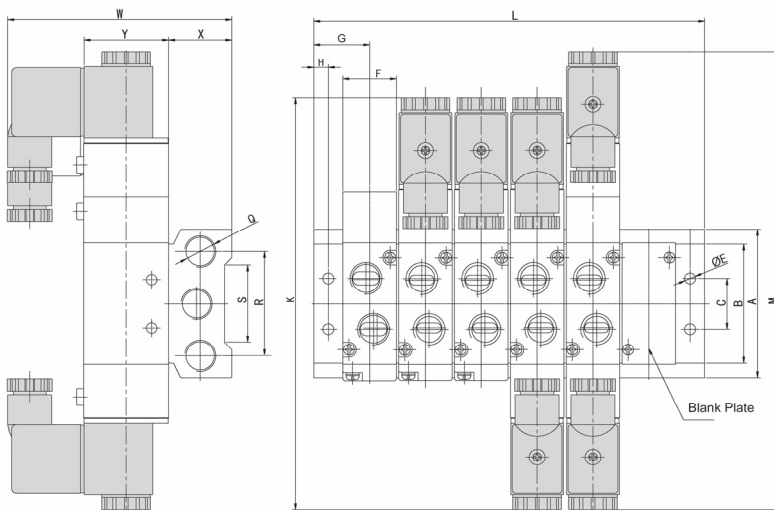

4V100-400M Manifold Dimensions

Model	A	B	C	E	F	G	H	K	L
100M	58	44	20	4.2	18.3	19	5	140	(N-1)*19+38
200M	61	51	21	4.3	22.4	23	6	170	(N-1)*23+46
300M	75	65	26	4.5	27.3	27	6	189	(N-1)*28+54
400M	104	95	32	5.5	34.3	31.5	7	222	(N-1)*35+63

Model	M	Q	R	S	T	W	X	Y
100M	155	1/4	40	30	M3x.5	78.5	25	27
200M	189	1/4	43	32	M3x.5	92.5	26	35
300M	208	3/8	53	48	M4x.7	99	30	40
400M	243	1/2	68	67	M4x.7	112	38	50

Manual Air Valves



	<p>Fine Quality</p> <p>Precision Engineered</p> <p>Advanced Design</p> <p>Excellent Prices</p>			



Contents

STC Manual Air Valve Numbering System	G2
STC Air Valve Specifications.....	G2
STC Manual Air Valves List Price.....	G3
STC Manual Air Valve Dimensions.....	G4-8

STC Manual Air Valve Numbering System

Ordering Part No. =
(eg. 4H230C-S)

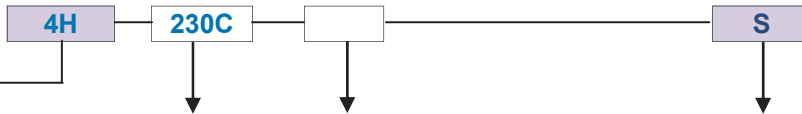

Model		# Way & # Position	PORT SIZE (NPT)	Options
Manual Air Valves	MOV	3 Way 2 Position	Blank = 1/8	Blank = Plunger (Non-Detented), E = Palm Button (Detented), PB =Palm Button (Non-Detented), PPL = Push Button (Non-Detented), R = Roller Lever (Non-Detented), TB = Knob Switch (Detented), Color: B =Blue, G =Green, K =Black, R =Red, Y =Yellow
Manual Air Valves	MSV	96322 = 3 Way 2 Position 86522 = 4 Way 2 Position	Blank = 1/4	
Hand Lever Valves	TSV			M = DETENTED S = NON-DETENTED (Spring Return)
Hand Lever Valves	4H	230C = 4 Way 3 Position (Closed Center) 230E = 4 Way 3 Position (Exhaust Center) 230P = 4 Way 3 Position (Pressure Center)		
Pull/Push Valves	3R	210 = 3 Way 2 Position		Blank = Detented
	4R	210 = 4 Way 2 Position		
Hand Handle Valves	HV	400 = 4 Way 3 Position 410 = 4 Way 2 Position		Blank = Non-Detented
	FV	220 = 2 Way 2 Position 320 = 3 Way 2 Position 420 = 4 Way 2 Position		
Foot Operated Valves	4F	210 = 4 Way 2 Position	Blank = Non-Detented, L = Detented (with lock), G = Guard	

STC Air Valve Specifications

Specifications								
Model	MSV Series	MOV Series	TSV Series	4H Series	3-4R Series	HV Series	4F Series	FV Series
Description	Hand Valves	Hand Valves	Lever Valves	Lever Valves	Pull/Push Valves	Hand Valves	Foot Valves	Foot Valves
Cv	0.89	0.67	1.0	0.89	0.89	1.68	0.89	0.89
Operating Pressure	0 to 150 PSI							
Operating Temperature	23 to 140 Deg. F (-5 to 60 Deg. C)							
Action	Direct Acting							
Working Medium	40 micron filtered air or inert gas							
Body Material	Aluminum (Anodized)							
Seal Material	NBR							
Lubrication	Not Required							

Specifications				
Model	ASC Series	AS Series	QE Series	ST Series
Description	Flow Control Valves	Flow Control Valves	Quick Exhaust Valves	Shuttle Valves
Orifice (mm)	1/8"= 4.6; 1/4"=6.0; 3/8"=6.2; 1/2"= 9.6; 3/4"=9.8			
Operating Pressure	0 to 150 PSI			
Operating Temperature	32 to 140 Deg. F (0 to 60 Deg. C)			
Working Medium	40 micron filtered air or inert gas			
Body Material	Aluminum (Anodized)			
Seal Material	NBR			
Lubrication	Not Required			

Manual Air Valves



1/4" NPT 4 Way 5 Port 2 Position Air Valves									
Model Price	MSV86522TB \$33.08	MSV86522EB \$33.08	MSV86522PB \$33.08	MSV86522PP \$33.08	MSV86522R \$33.08	MPV522 \$46.97	TSV86522 (M or S) \$34.85	4R210(M or S) \$23.40	
Description	Two Position Detented Switch Cv 0.89	Emergency Stop Detented Cv 0.89	Palm Button Momentary Cv 0.89	Push Button Momentary Cv 0.89	Roller Lever Cv 0.89	Toggle Switch Cv 0.89	Lever M = Detented S = Non-detented	Pull/Push M = Detented S = Non-detented	
1/4" NPT 3 Way 3 Port 2 Position Air Valves									
Model Price	MSV98322TB \$31.37	MSV98322EB \$31.37	MSV98322PB \$32.45	MSV98322PP \$31.37	MSV98322R \$31.37		TSV98322 (M or S) \$33.08	3R210(M or S) \$22.81	
Description	Two Position Switch Cv 0.89	Emergency Stop Detented Cv 0.89	Palm Button Momentary Cv 0.89	Push Button Momentary Cv 0.89	Roller Lever Momentary Cv 0.89		Lever M = Detented S = Non-detented	Pull/Push M = Detented S = Non-detented	
1/8" NPT 3 Way 2 Port 2 Position Air Valves						1/4" NPT 4 Way 5 Port 3 Position Air Valves			
Model Price	MOV-01 \$19.97	MOV-03 \$19.97	MOV-03A \$19.97	MOV-02 \$19.97			4H230C (M or S) \$72.18	4H230E (M or S) \$72.18	4H230P (M or S) \$72.18
Description	Two Position Switch Cv 0.67	Emergency Stop Detented Cv 0.67	Push Button Momentary Cv 0.67	Roller Lever Momentary Cv 0.67		Description	3 Position, 4 Way Closed Center M = Detented S = Non-detented	3 Position, 4 Way Exhaust Center M = Detented S = Non-detented	3 Position, 4 Way Pressure Center M = Detented S = Non-detented
1/4" NPT Air Valves									
Model Price	HV410 \$35.97	HV420 \$35.97	FV220 \$38.22	FV320 \$38.22	FV420 \$40.50	4F210 \$46.21	4F210L \$59.30	4F210G \$72.43	
Description	2 Position 4 Way Valve Cv 1.68	3 Position 4 Way Valve Closed Center Cv 1.68	2 Way Momentary Foot Valve	3 Way Momentary Foot Valve	4 Way Momentary Foot Valve	4 Way Momentary Foot Valve	4 Way Detented Foot Valve	4 Way Shielded Momentary Foot Valve	

Metal Fittings							
Model	Quick Exhaust	Shuttle Valve	In-line Flow Control	In-line Flow Control	Speed Control Muffler	Muffler	Union Valve
Port	QE	ST	ASC	AS	BESL	BSL	UV
10-32					BESL 10-32	BSL 10-32	
1/8	QE N1/8	ST N1/8	ASC N1/8	AS N1/8	BESL N1/8	BSL N1/8	UV 1/4-1/4
1/4	QE N1/4	ST N1/4	ASC N1/4	AS N1/4	BESL N1/4	BSL N1/4	UV 6-6
3/8	QE N3/8	ST N3/8	ASC N3/8	AS N3/8	BESL N3/8	BSL N3/8	
1/2	QE N1/2	ST N1/2	ASC N1/2	AS N1/2	BESL N1/2	BSL N1/2	
3/4	QE N3/4	ST N3/4					

Push Button Dimensions

MODEL: MSV86522-XX

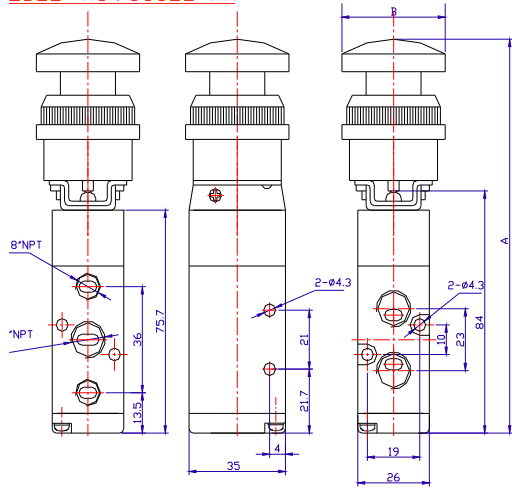

MODEL: MSV98322-XX

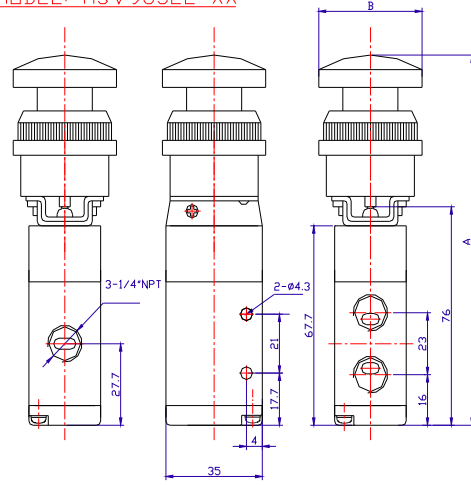

MODEL: MDV-XX

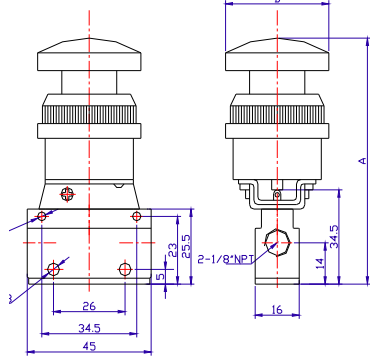

BUTTON STYLE

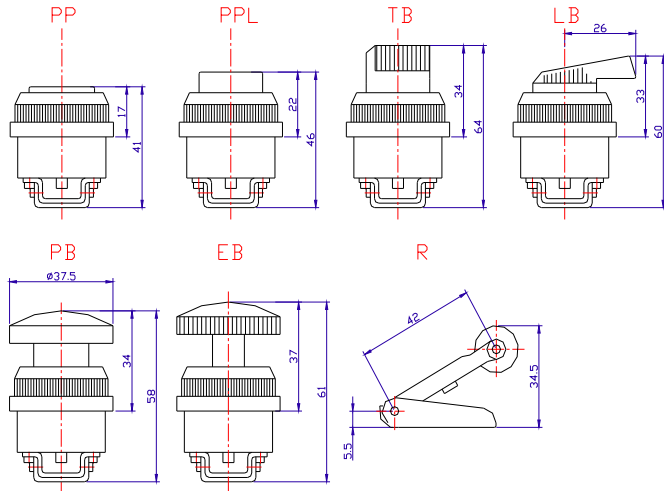

PANEL MOUNT HOLE SIZE 1 3/16" (30 MM)

4R210 Unit in mm

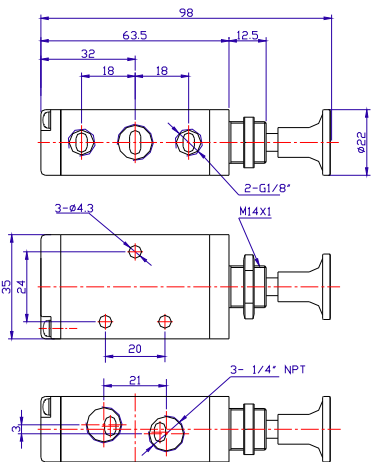

3R210

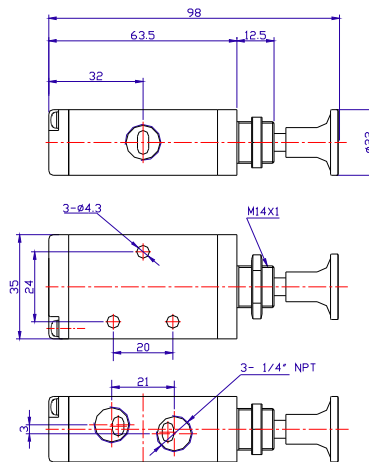

Unit in (mm)

Hand Lever Dimensions

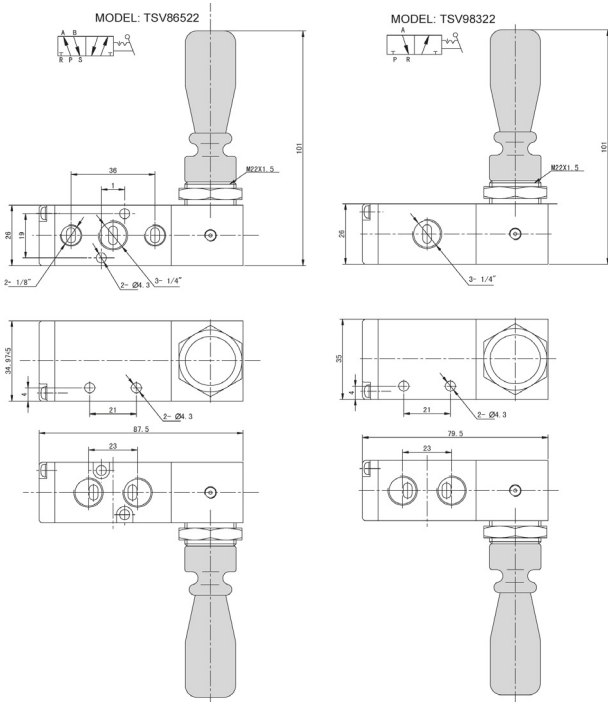

MPV

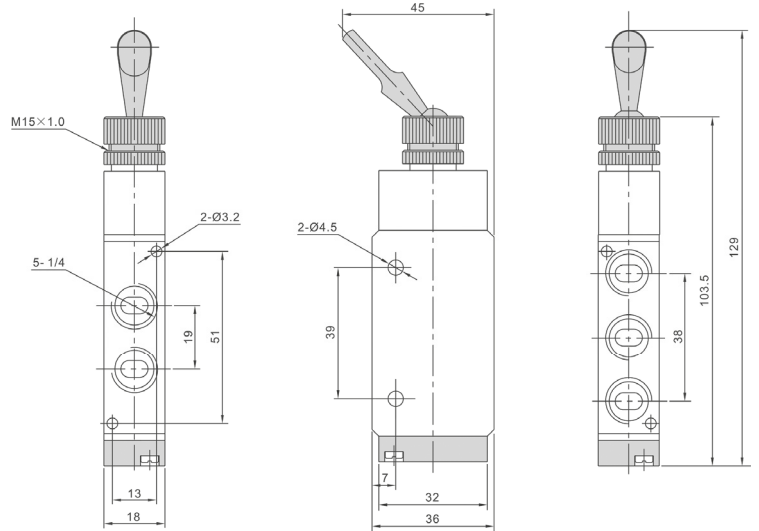

MODEL: 4H230C-1/4

5 PORT 3 POSITION MOMENTARY HAND LEVER VALVE

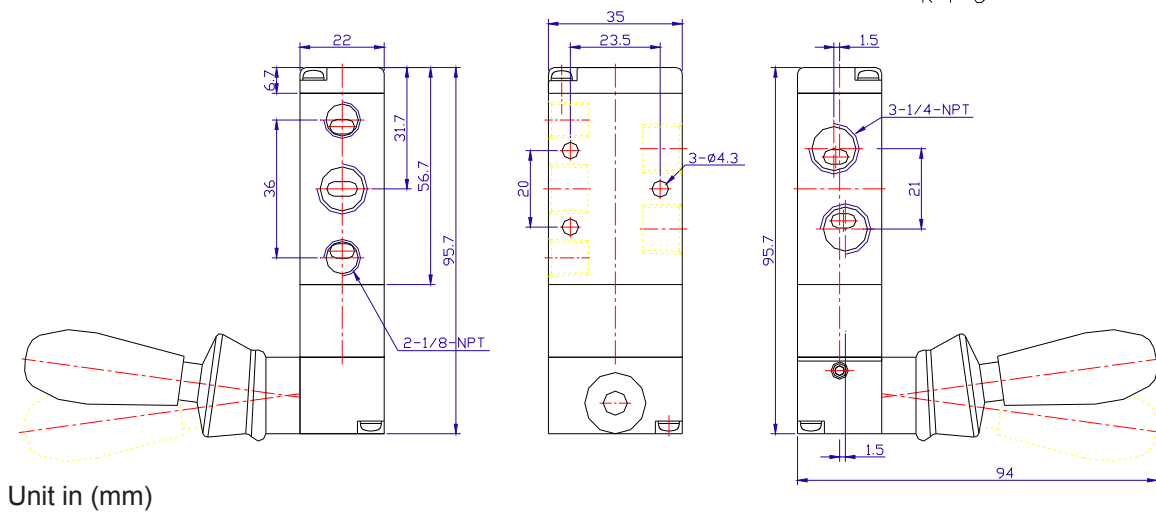
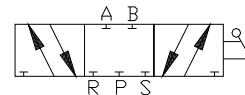

Hand Lever Dimensions

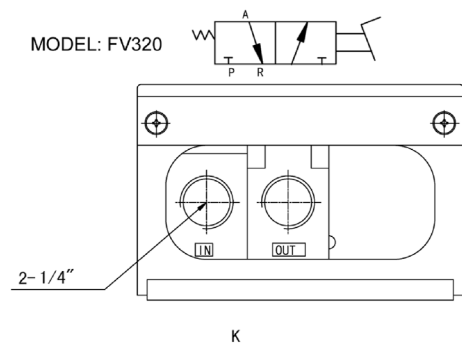
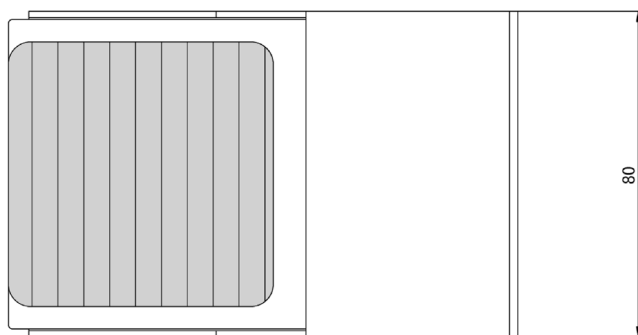
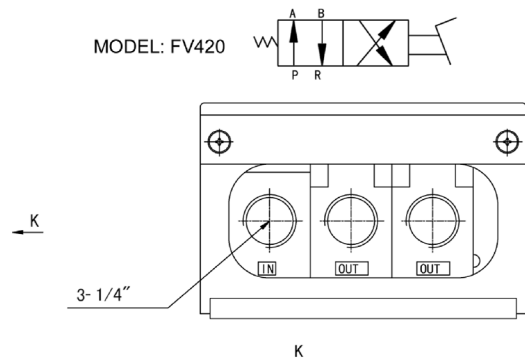
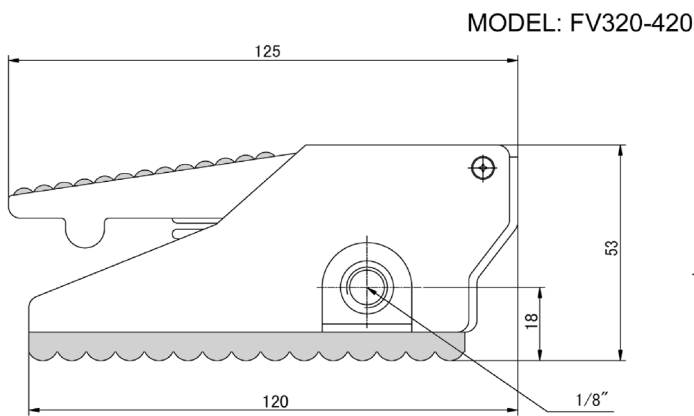
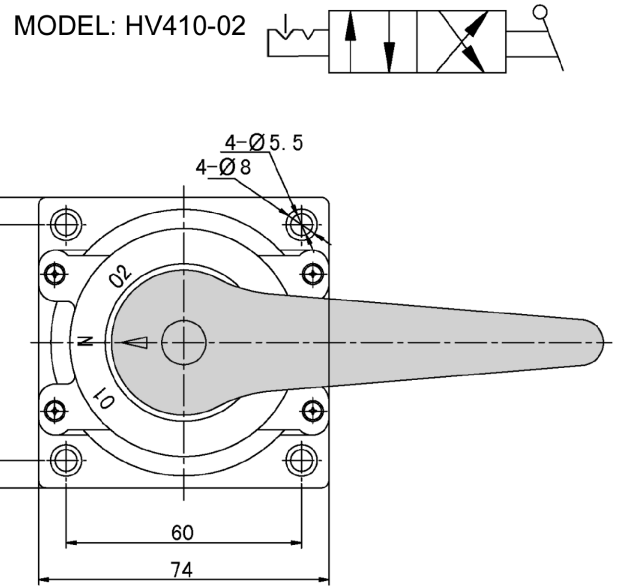
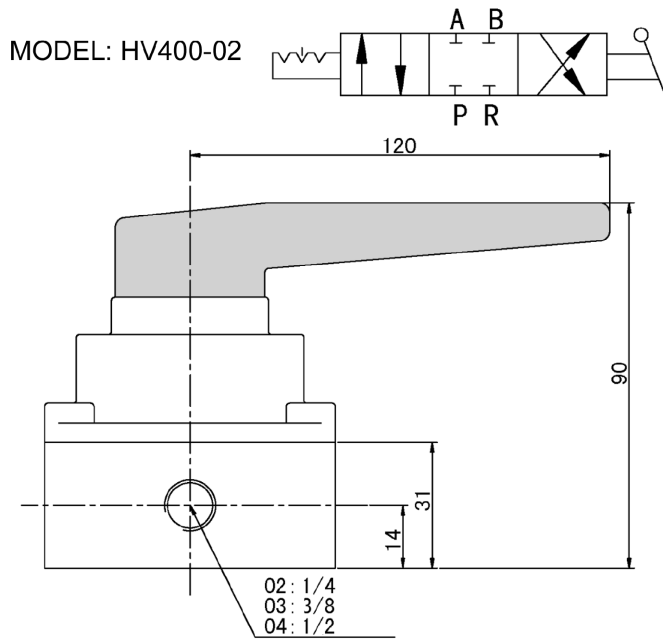

Unit in (mm)

Foot Pedal Dimensions

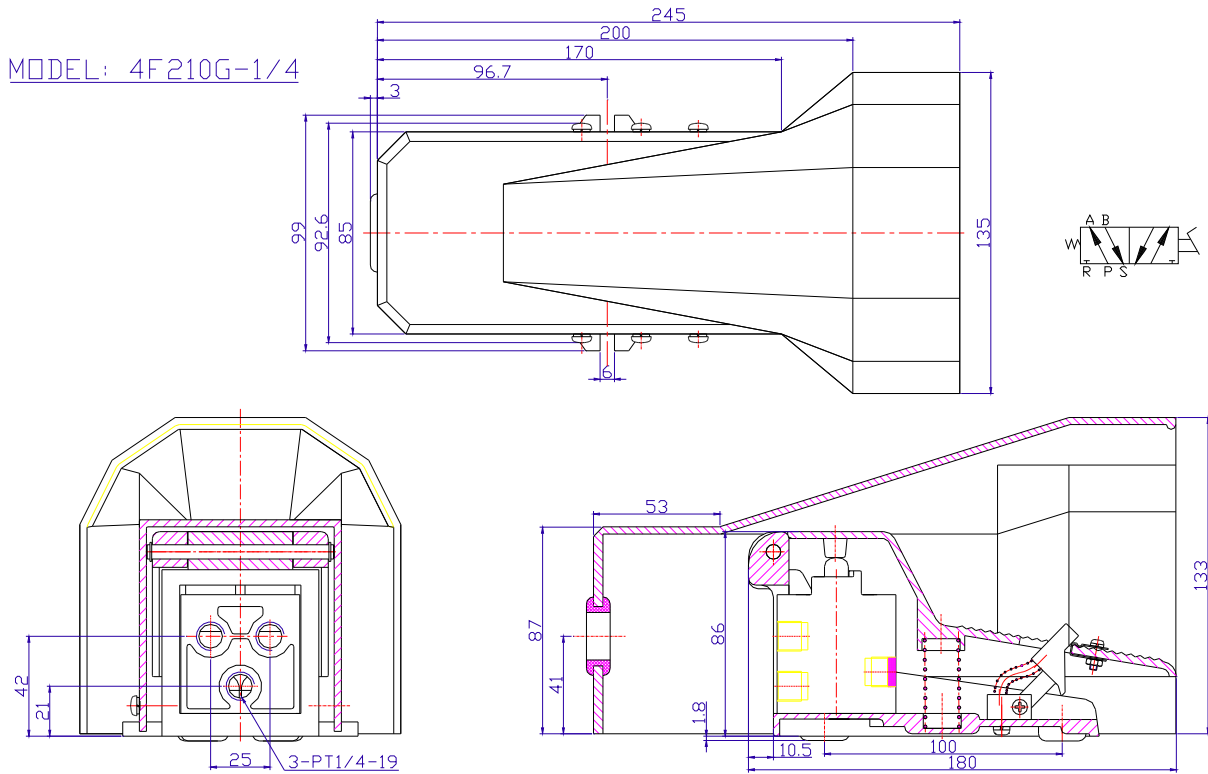
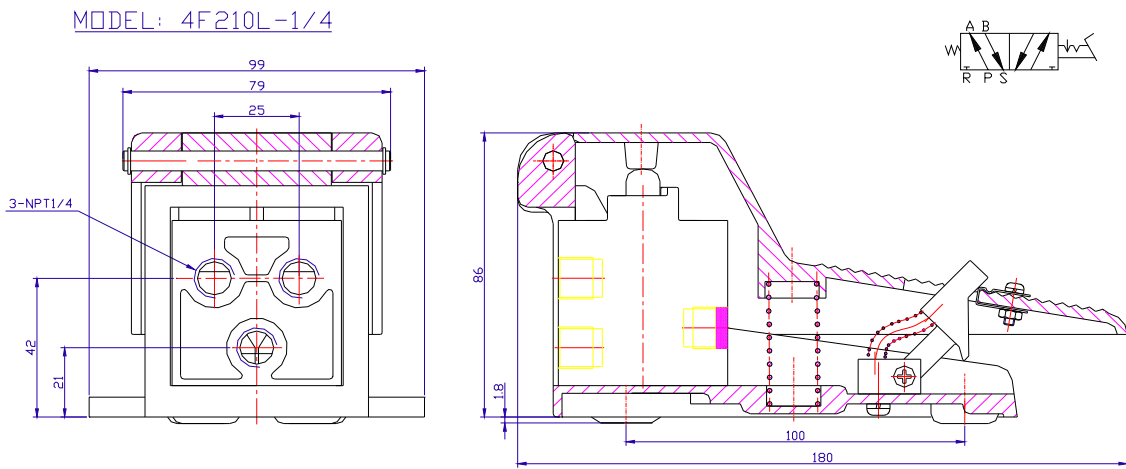
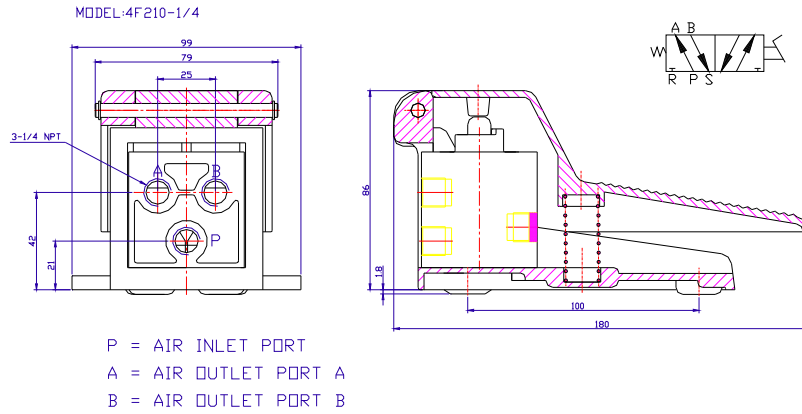

Unit in (mm)

Quick Exhaust Valve

MODEL: QE

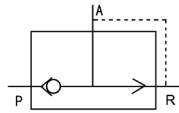
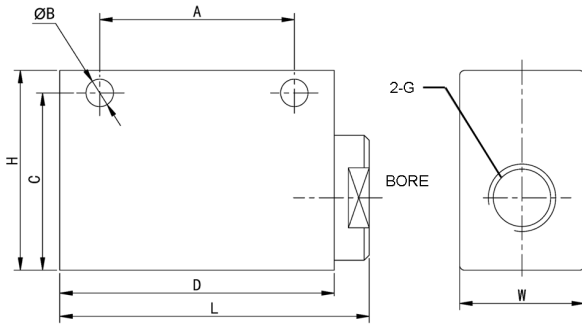

Quick Exhaust Valve (MM)										
	Bore (NPT)	G (NPT)	L	W	H	A	B	C	D	Cv
QE-01	1/4	1/8	46	20	32	30	4.3	27.0	40	1.0
QE-02	3/8	1/4	62	25	40	39	5.6	33.5	55	1.3
QE-03	1/2	3/8	62	25	40	39	5.6	33.5	55	1.4
QE-04	3/4	1/2	98	38	64	60	8.5	51.0	90	4.0
QE-06	1	3/4	98	38	64	60	8.5	51.0	90	4.1

Shuttle Valve

MODEL: ST

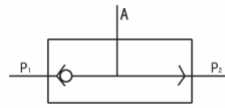
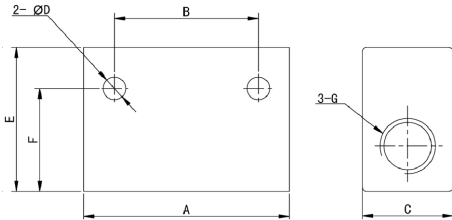

SHUTTLE VALVE (MM)								
	A	B	C	D	E	F	G (NPT)	Cv
ST-01	40	24	16	4.5	25	21	1/8	0.35
ST-02	50	35	22	5.5	35	25	1/4	1.0
ST-03	75	48	30	7.0	50	42	3/8	2.0
ST-04	75	48	30	7.0	50	42	1/2	3.5
ST-06	110	72	40	7.0	70	58	3/4	6.0
ST-08	110	72	40	7.0	70	58	1	100.

MODEL: ASC N1/8

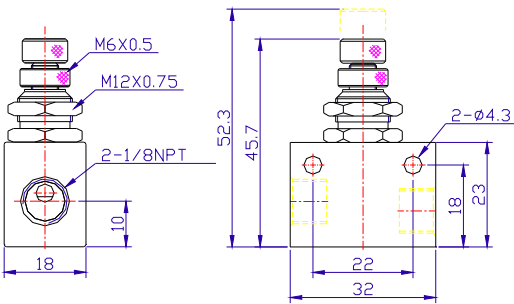

MODEL: ASC N1/4

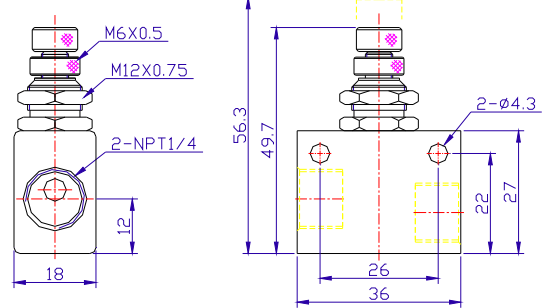

MODEL: ASC N3/8

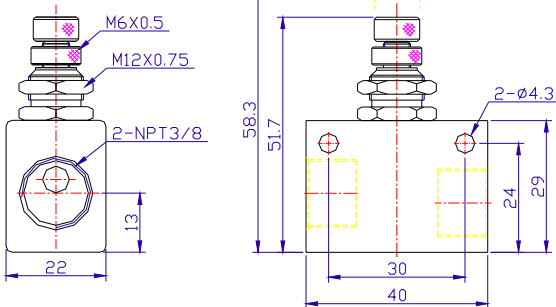

MODEL: ASC N1/2

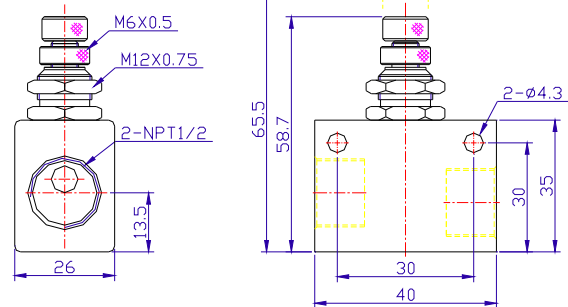

Unit in (mm)

STC Air Cylinders

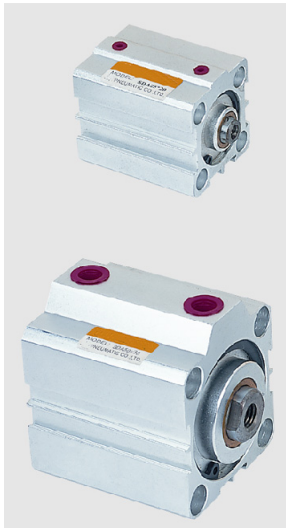
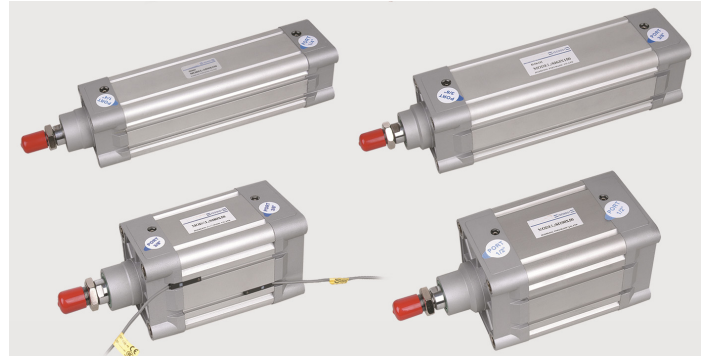
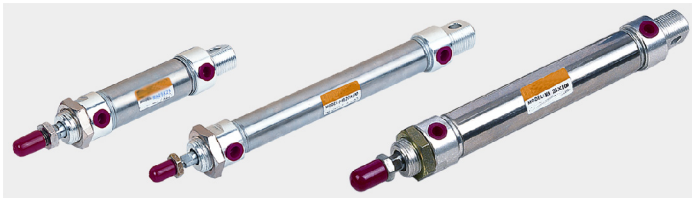
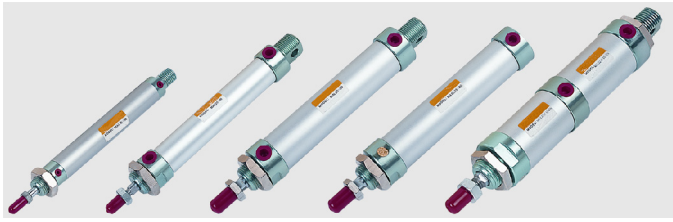

Fine Quality

Precision Engineered

Advanced Design

Excellent Prices

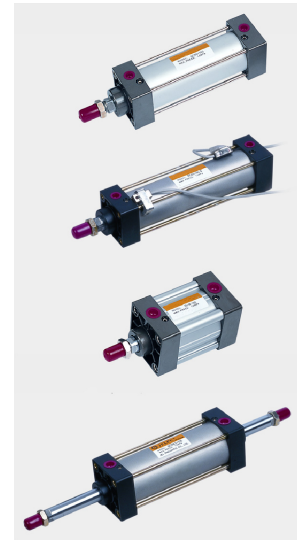

Contents

STC Air Cylinder Numbering System.....	H2
Cylinder Mounting Bracket Dimensions.....	H3
MA & MAL Series Round Cylinder Dimensions.....	H4-5
SC &SU Series Tie Rod Cylinder Dimensions.....	H6
SDA Series Compact Cylinder Dimensions.....	H6
SDA/SSA/STA Series Compact Cylinder Dimensions.....	H7
Air Cylinder Technical Data	H8

STC Air Cylinder Numbering System

Ordering Part No. =
(eg. MAJ-20-50-SDB-S,J=25)

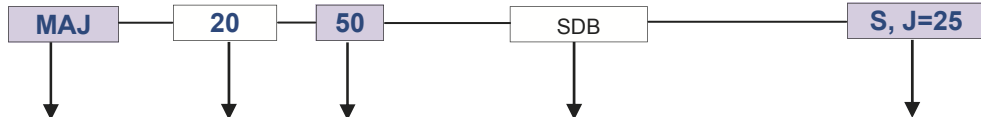

Model	Bore (mm)	Stroke (mm)	Mounting	Options
MA Series Stainless Steel Round Cylinder				
MA = Double Acting MSA = Single Acting (Spring Return) MTA = Single Acting (Spring Extend) MAD = Double Shaft MAJ = Double Shaft with Adjustable Stroke	16 20 25 32 40	25-500	Blank = Front Nose Mount and Back Pivot Mount (Standard) LB = Front & Back Foot Mount FA = Front Flange Type FB = Back Flange SDB = Back Clevis Bracket with Pin	S = Magnet for Hall Sensor J = Adjustable Stroke (in MM)
MAL Series Aluminum Round Cylinder				
MAL = Double Acting MSAL = Single Acting (Spring Return) MTAL = Single Acting (Spring Extend) MALD = Double Shaft MALJ = Double Shaft with Adjustable Stroke	16 20 25 32 40	25-500	Blank = Front Nose Mount and Back Pivot Mount (Standard) LB = Front & Back Foot Mount FA = Front Flange Type FB = Back Flange SDB = Back Clevis Bracket with Pin	S = Magnet for Hall Sensor J = Adjustable Stroke (in MM)
SC Series Tie-Rod Cylinder				
SC = Double Acting SCA = Single Acting SCD = Double Shaft SCJ = Double Shaft with Adjustable Stroke	32 40 50 63 80 100 125 160 200	25-1000	Blank = Front Nose Mount and Back Pivot Mount (Standard) LB = Front & Back Foot Mount FA = Front Flange Type FB = Back Flange	S = Magnet for Hall Sensor J = Adjustable Stroke (in MM)
SU Series Enclosed Tie-Rod Cylinder				
SU = Double Acting SUA = Single Acting SUD = Double Shaft SUJ = Double Shaft with Adjustable Stroke	32 40 50 63 80 100 125 160 200	25-1000	Blank = Front Nose Mount and Back Pivot Mount (Standard) LB = Front & Back Foot Mount CA = Pivot Bracket with Pin CB = Clevis Bracket with Pin LB = Foot Mount TC = Swing Type	S = Magnet for Hall Sensor J = Adjustable Stroke (in MM)
SDA Series Compact Round Cylinder				
SDA = Double Acting SSA = Single Acting STA = Reverse Acting SDAD = Double Shaft SDAJ = Double Shaft with Adjustable Stroke	12 16 20 25 32 40 50 63 80 100	25-1000	Blank = Front Nose Mount and Back Pivot Mount (Standard) LB = Front & Back Foot Mount TCM = Swinging Type attaching foot seat	S = Magnet for Hall Sensor J = Adjustable Stroke (in MM) Shaft Style: Blank: Shaft with Female Thread B: Shaft with Male Thread N: Shaft with NO Thread

Part No.	Description	Specifications
AL-03R-MA MAL	Reed Switch for MA or MAL cylinder	Reed Switch 5-240 V (DC/AC) 100 mA 10W (with 39" Lead Wires)
AL-11R-SDA	Reed Switch for SDA cylinder	
AL-21R-SC SU	Reed Switch for SC or SU cylinder	
AL-30R-SI	Reed Switch for SI cylinder	

Cylinder Mounting Bracket Dimensions

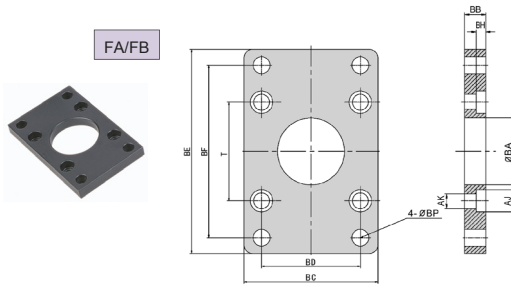

FA/FB (Front or Back Flange)									
Bore	32	40	50	63	80	100	125	160	200
BA	28.3	32.3	38.3	38.3	47.3	47.5	56	63	81
BB	10	10	10	12	16	16	20	25	25
BC	47	52	65	76	95	115	140	180	220
BD	33	36	47	56	70	84	90	115	135
BE	72	84	104	116	143	162	224	280	320
BF	58	70	86	98	119	138	180	230	270
BG	6.5	6.5	6.5	8.5	11	11	15	20	20
BH	11	11	14	14	17	17	19	25	25
AJ	6.5	6.5	8.5	8.5	11	11	13	17	17
BP	7	7	9	9	12	12	16	18	22
T	33	37	47	56	70	84	110	140	175

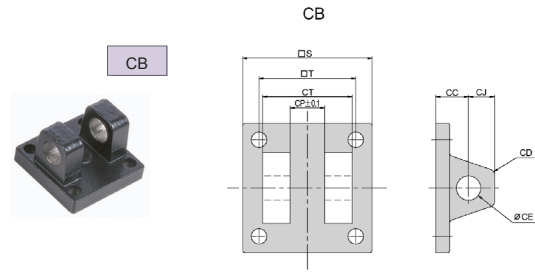

CB (Double Rear Clevis Bracket with Pin)									
Bore	32	40	50	63	80	100	125	160	200
CC	19	19	19	19	32	32	50	55	60
CD	5	5	3	3	8	8	25	30	30
CE	12	14	14	14	20	20	25	30	30
CJ	13	13	15	15	21	21	25	30	30
CP	16	21	20	20	32	32	70	90	90
CT	32	44	52	52	64	64	120	160	160
PAI	41	52	60	60	74	74	130	170	170
PBI	34	46	54	54	66	66	122	162	162
S	48	50	62	75	94	112	140	180	220
T	33	37	47	56	70	84	110	140	175

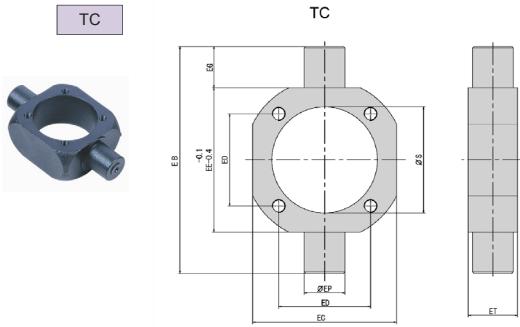

TC (Center Trunnion)								
Bore	40	50	63	80	100	125	160	200
EB	113	126	138	164	182	210	264	336
EC	63	76	88	114	132	160	200	240
ED	37	47	56	70	84	110	140	175
EE	63	76	88	114	132	160	200	240
EG	25	25	25	25	25	25	32	48
EP	25	25	25	25	25	25	32	38
ET	30	30	30	30	30	30	38	44
S	46	56	69	88	108	135	173	213

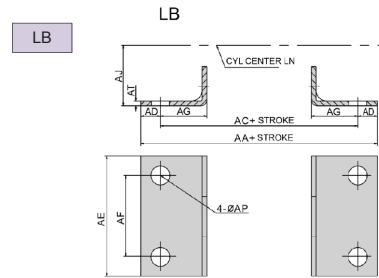

LB (Foot Mount)									
Bore	32	40	50	63	80	100	125	160	200
AA	153	169	173	184	200	210	249	328	380
AC	134	140	149	158	168	174	213	288	320
AD	9.5	15	12	12	16	18	18	20	30
AE	50	57	68	80	97	112	140	180	220
AF	33	36	47	56	70	84	90	115	135
AG	21	24	28	31	30	30	45	60	70
AJ	28	30	37	41	49	57	90	115	135
AP	9	12	12	12	14	14	16	18	22
AT	3.2	3.2	3.2	3.2	4	4	6	6	10

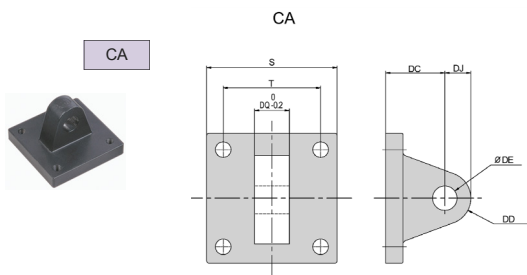

CA (Single Rear Clevis with Pin)									
Bore	32	40	50	63	80	100	125	160	200
S	48	50	62	75	94	112	140	180	220
T	33	37	47	56	70	84	110	140	175
DC	34	34	34	34	48	48	50	55	60
DD	14	14	15	15	20	20	25	30	30
DE	12	14	14	14	20	20	25	30	30
DL	14	14	15	15	20	20	25	30	30
DQ	16	20	20	20	32	32	70	90	90

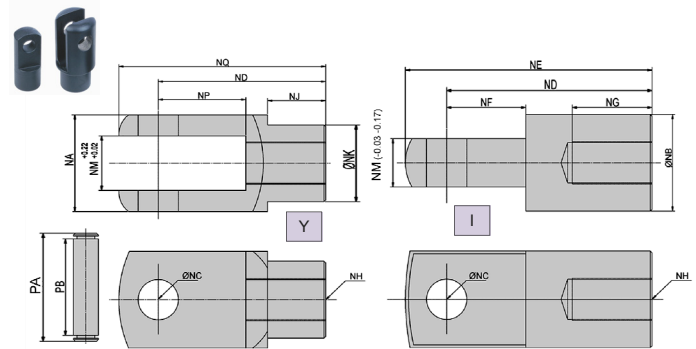

Y (Rod Clevis with Pin), I (Rod Pivot with Pin)															
	NA	NB	NC	ND	NE	NF	NG	NH	NJ	NK	NM	NP	NQ	PA	PB
32	19	20	10	40	52	15	20	M10X1.25	12	18	10	20	52	26	20
40	25	24	12	48	67	24	20	M12X1.25	20	23	12	24	62	33	27
50	32	32	16	64	89	32	23	M16X1.5	22	30	16	32	83	39	33
63	32	32	16	64	89	32	23	M16X1.5	22	30	16	32	83	39	33
80	44	40	20	80	112	40	30	M20X1.5	30	39	20	40	105	53	45
100	44	40	20	80	112	40	30	M20X1.5	30	39	20	40	105	53	45

MA Series Stainless Steel Round Cylinder Dimensions

MA-CA

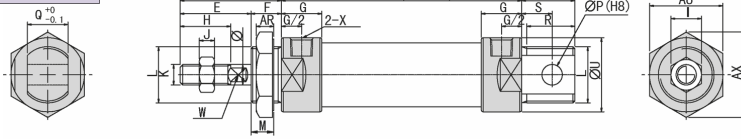

MA-CM

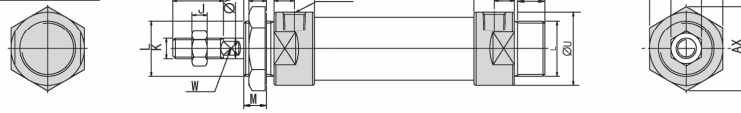

MA-U

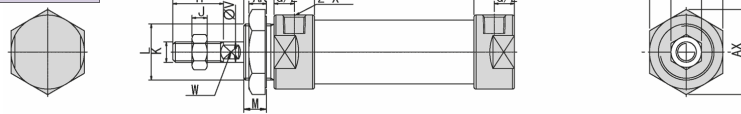

Model: MA														
Bore	A	A1	A2	B	C	D	D1	E	F	G	H	I	J	K
16	114	114	98	38	60	15	15	22	16	10	16	10	5	M6 X 1
20	137	128	116	40	76	21	12	28	12	16	20	12	6	M8 X 1.25
25	141	134	120	44	76	21	14	30	14	16	22	17	6	M10 X 1.25
32	147	134	120	44	76	27	14	30	14	16	22	17	6	M10 X 1.25
40	149	136	122	46	76	27	14	32	14	16.7	24	17	7	M12 X 1.25
Bore	L	M	P	Q	R	R1	S	U	V	W	X	AR	AX	AY
16	M16 X 1.5	14	6	12	14	14	9	21	6	5	M5	6	24	28
20	M22 X 1.5	10	8	16	19	12	12	27	8	6	G1/8	7	33	29
25	M22 X 1.5	12	8	16	19	14	12	30	10	8	G1/8	7	33	29
32	M24 X 2.0	12	10	16	25	14	15	35	12	10	G1/8	8	37	32
40	M30 X 2.0	12	12	20	25	14	15	42	16	14	G1/8	9	47	41

MSA-CA

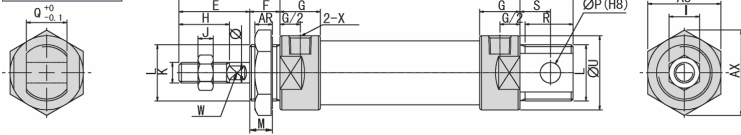

MSA-CM

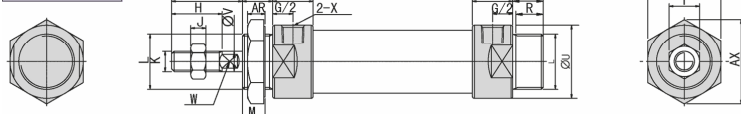

MSA-U

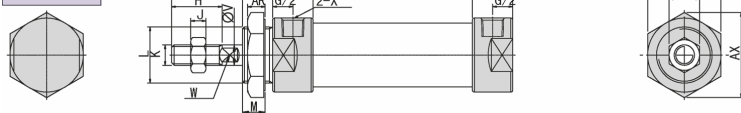

Symbol	A		A1		A2		B	C		D	E	F	G	H	I
Bore	0-50	51-100	0-50	51-100	0-50	51-100		0-50	51-100						
20	137	162	128	153	116	141	40	76	101.0	21	12	28	12	16	20
25	141	166	134	159	120	145	44	76	101.0	21	14	30	14	16	22
32	147	172	134	159	120	145	44	76	101.0	27	14	30	14	16	22
40	149	174	136	161	122	147	46	76	101.0	27	14	32	14	22	24

Symbol	J	K	L	M	P	Q	R	R1	S	U	V	W	X	AR	AX	AY
20	6	M8 X 1.25	M22 X 1.5	10	8	16	19	12	12	27	8	6	G1/8	7	33	29
25	6	M10 X 1.25	M22 X 1.5	12	8	16	19	14	12	30	10	8	G1/8	7	33	29
32	6	M10 X 1.25	M24 X 2.0	12	10	16	25	14	15	35	12	10	G1/8	8	37	32
40	7	M12 X 1.25	M30 X 2.0	12	12	20	25	14	15	41.6	16	14	G1/8	9	47	41

MAD

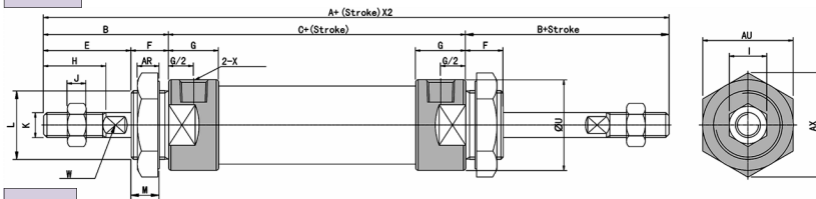

MAJ

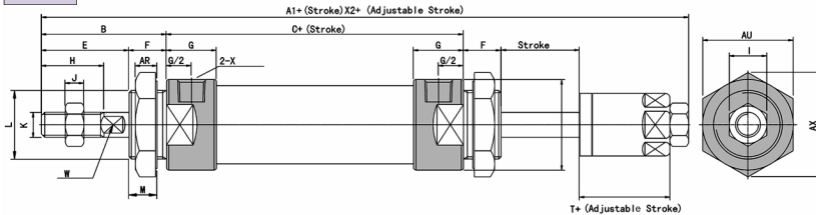

Bore	A	A1	B	C	E	F	G	H	I	J	K
20	156	153	40	70	28	12	16	20	12	6	M8 X 1.25
25	164	161	44	70	30	14	16	22	17	6	M10 X 1.25
32	164	161	44	70	30	14	16	22	17	6	M10 X 1.25
40	168	164	46	92	32	14	22	24	17	7	M12 X 1.25
Bore	L	M	U	V	W	X	AR	AX	AY	T	
20	M22 X 1.5	10	29	8	6	G1/8	7	33	29	19	
25	M22 X 1.5	12	34	10	8	G1/8	7	33	29	21	
32	M24 X 1.5	12	39.5	12	10	G1/8	8	37	32	21	
40	M30 X 2.0	12	49.5	16	14	G1/4	9	47	41	21	

MAL Series Aluminum Round Cylinder Dimensions

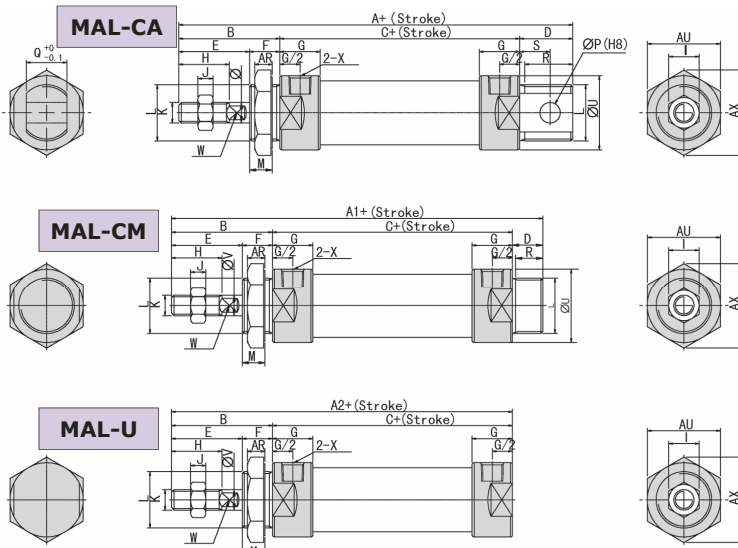

Bore	A	A1	A2	B	C	D	D1	E	F	G	H	I	J	K
16	104	104	90	38	52	15	15	24	14	11	16	10	5	M6 X 1
20	131	122	110	40	70	21	12	28	12	16	20	12	6	M8 X 1.25
25	135	128	114	44	70	21	14	30	14	16	22	17	6	M10 X 1.25
32	141	128	114	44	70	27	14	30	14	16	22	17	6	M10 X 1.25
40	165	152	138	46	92	27	14	32	14	22	24	17	7	M12 X 1.25
Bore	L	M	P	Q	R	R1	S	U	V	W	X	AR	AX	AY
16	M16 X 1.5	8	6	12	13	13	6	20	6	/	M5	7	24	28
20	M22 X 1.5	10	8	16	19	12	12	29	8	6	G1/8	7	33	29
25	M22 X 1.5	12	8	16	19	14	12	34	10	8	G1/8	7	33	29
32	M24 X 2.0	12	10	16	25	14	15	40	12	10	G1/8	8	37	32
40	M30 X 2.0	12	12	20	25	14	15	50	16	14	G1/4	9	47	41

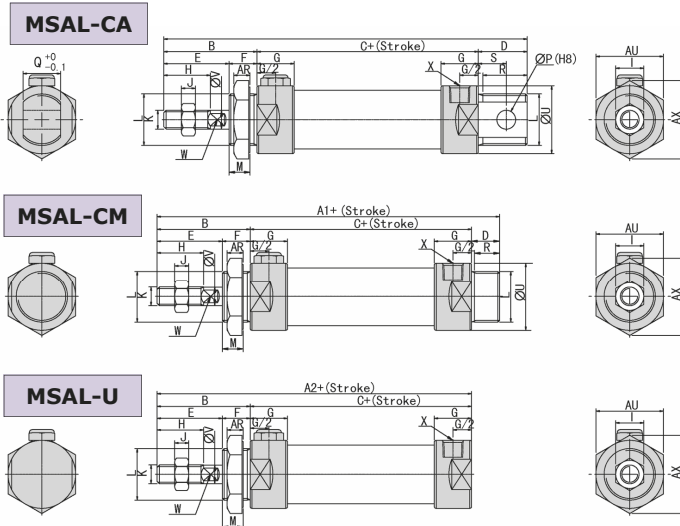

Symbol	A		A1		A2		C		D	D1	E	F	G	H	I	
Bore	0-50	51-100	0-50	51-100	0-50	51-100	0-50	51-100								
20	131	156	122	147	110	135	40	70	95	21	12	28	12	16	20	12
25	135	160	128	153	114	139	44	70	95	21	14	30	14	16	22	17
32	141	166	128	153	114	139	44	70	95	27	14	30	14	16	22	17
40	165	190	152	177	138	163	46	92	117	27	14	32	14	22	24	17

Bore	J	K	L	M	P	Q	R	R1	S	U	V	W	X	AR	AX	AY
20	6	M8 X 1.25	M22 X 1.5	10	8	16	19	12	12	29	8	6	G1/8	7	33	29
25	6	M10 X 1.25	M22 X 1.5	12	8	16	19	14	12	34	10	8	G1/8	7	33	29
32	6	M10 X 1.25	M24 X 2.0	12	10	16	25	14	15	39.5	12	10	G1/8	8	37	32
40	7	M12 X 1.25	M30 X 2.0	12	12	20	25	14	15	49.5	16	14	G1/4	9	47	41

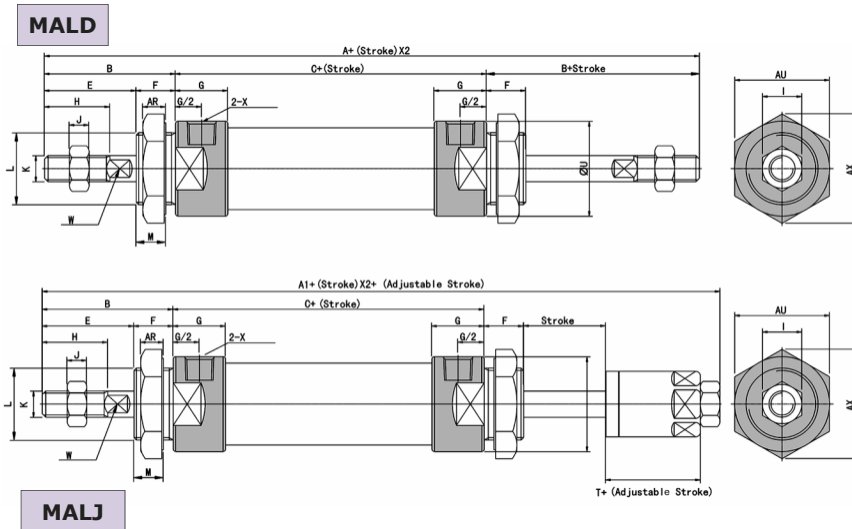

Bore	A	A1	B	C	E	F	G	H	I	J	K
20	131	122	40	70	28	12	16	20	12	6	M8 X 1.25
25	135	128	44	70	30	14	16	22	17	6	M10 X 1.25
32	141	128	44	70	30	14	16	22	17	6	M10 X 1.25
40	165	152	46	92	32	14	22	24	17	7	M12 X 1.25
Bore	L	M	U	V	W	X	AR	AX	AY	T	
20	M22 X 1.5	10	29	8	6	G1/8	7	33	29	19	
25	M22 X 1.5	12	34	10	8	G1/8	7	33	29	21	
32	M24 X 2.0	12	39.5	12	10	G1/8	8	37	32	21	
40	M30 X 2.0	12	49.5	16	14	G1/4	9	47	41	21	

SC & SU Series Tie Rod Cylinder Dimensions | SDA Series Compact Cylinder Dimensions

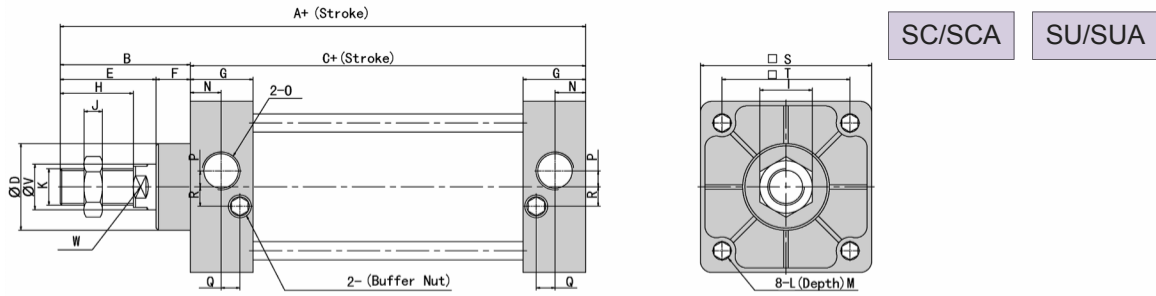

SC/SCA

SU/SUA

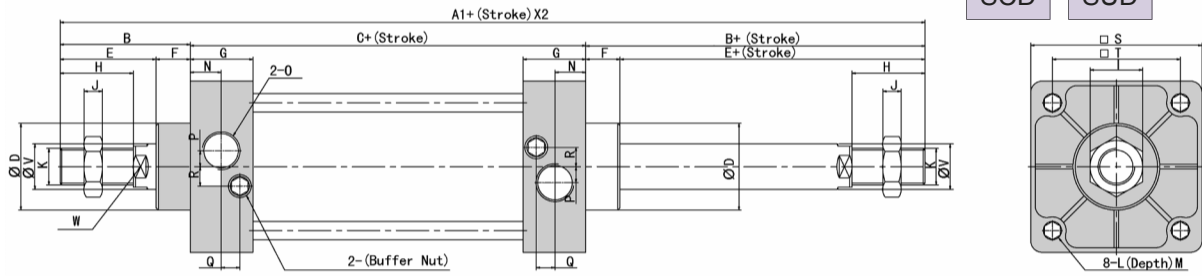

SCD

SUD

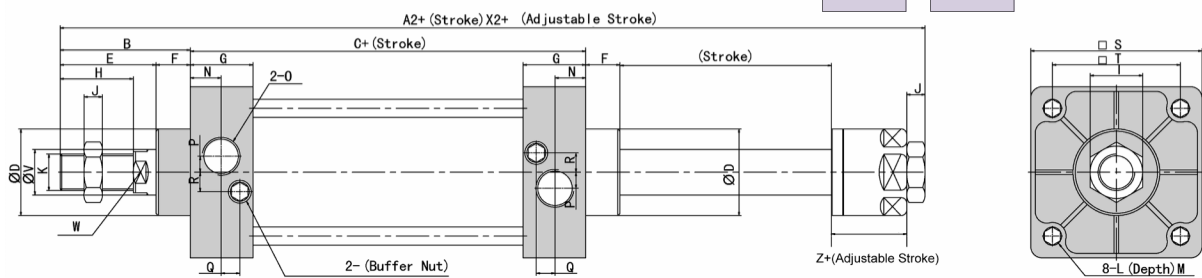

SCJ

SUJ

BORE	A	A1	A2	B	C	D	E	F	G	H	I	J	K	L	M	N	O	P	Q	R	S	T	V	W	Z
32	140	187	182	47	93	28	32	15	27.5	22	17	6	M10X1.25	M6X1	9.5	13.5	1/8	3.5	7.5	7	45	33	12	12	21
40	142	191	185	48	93	32	34	15	27.5	24	17	7	M12X1.25	M6X1	9.5	13.5	1/4	6	8.2	9	50	37	16	14	21
50	150	207	196	57	93	38	42	15	27.5	32	23	8	M16X1.25	M6X1	9.5	13.5	1/4	8.5	8.2	9	62	47	20	17	23
63	153	210	199	57	96	38	42	15	27.5	32	23	8	M16X1.25	M8X1.25	9.5	13.5	3/8	7	8.2	8.5	75	56	20	17	23
80	183	258	243	75	108	47	54	21	33	40	26	10	M20X1.25	M10X1.5	11.5	16.5	3/8	10	9.5	14	94	70	25	22	29
100	189	264	249	75	114	47	54	21	33	40	26	10	M20X1.25	M10X1.5	11.5	16.5	1/2	11	9.5	14	112	84	25	22	29
125	226	/	/	104	122	55	70	34	33	54	40	10	M27X1.25	M12X1.75	15.5	16.5	1/2	/	/	/	140	110	32	27	/
160	291	/	/	123	168	62	91	32	50	72	55	18	M36X1.25	M16X2	17.5	25	1/2	/	/	/	180	140	40	36	/
200	347	/	/	167	180	80	112	55	50	72	55	18	M36X1.25	M16X2	17.5	25	3/4	/	/	/	220	175	40	36	/

MODEL: SDA12-16

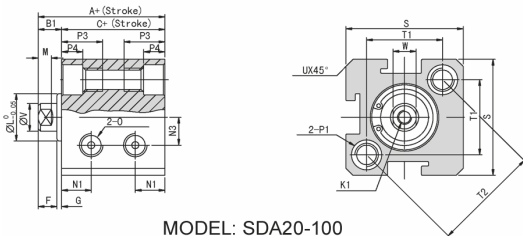

MODEL: SDA20-100

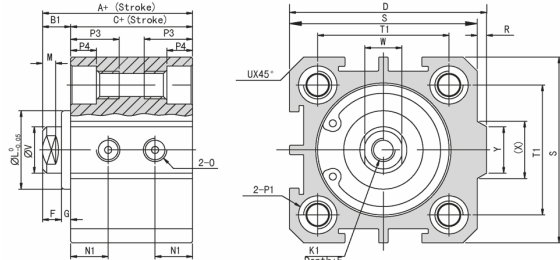

SDA Bore	Standard Type			With Magnet			D	E	F	G	K1	L
	A	B1	C	A	B1	C						
12	22	5	17	32	5	27	-	6	4	1	M3X0.5	10.2
16	24	5.5	18.5	34	5.5	28.5	-	6	4	1.5	M3X0.5	11
20	25	5.5	19.5	35	5.5	29.5	6	8	4	1.5	M4X0.7	16
25	27	6	21	37	6	34	42	10	4	2	M5X0.8	17
32	31.5	7	24.5	41.5	7	34.5	50	12	4	3	M6X1	22
40	33	7	26	43	7	36	58.5	12	4	3	M8X1.25	28
50	37	9	28	47	9	38	71.5	15	5	4	M10X1.5	38
63	41	9	32	51	9	42	84.5	15	5	4	M10X1.5	40
80	52	11	41	62	11	51	104	15	6	5	M14X1.5	45
100	63	12	51	73	12	61	124	18	7	5	M18X1.5	55

Bores	M	N1	N3	O	P1/DIA	P3	P4	R	S	T1	T2	U	V	W	X	Y
12	2.8	6.3	6	M5X0.8	M5X0.8X4.2	12	4.5	-	25	16.2	23	1.6	6	5	-	-
16	2.8	7.3	6.5	M5X0.8	M5X0.8X4.2	12	4.5	-	29	19.8	28	1.6	6	5	-	-
20	2.8	7.5	-	M5X0.8	M5X0.8X4.2	14	4.5	2	34	24	-	2.1	8	6	11.3	10
25	2.8	8	-	M5X0.8	M6X1.0X4.6	15	5.5	2	40	28	-	3.1	10	8	12	10
32	2.8	9	-	1/8	M6X1.0X4.6	16	5.5	6	44	34	-	2.15	12	10	18.3	15
40	2.8	10	-	1/8	M8X1.25X6.5	20	7.5	6.5	52	40	-	2.25	16	14	21.3	16
50	2.8	10.5	-	1/4	M8X1.25X6.5	25	8.5	9.5	62	48	-	4.15	20	17	30	20
63	2.8	11.8	-	1/4	M8X1.25X6.5	25	8.5	9.5	75	60	-	3.15	20	17	28.7	20
80	4	14.5	-	3/8	M12X1.75X9.2	25	10.5	10	94	74	-	3.65	25	22	36	26
100	4	20.5	-	3/8	M12X1.75X11.3	30	13	10	114	90	-	3.65	32	27	35	26

SDA/SSA/STA Series Compact Cylinder Shaft Dimensions



SDA/SSA/STA Series Compact Cylinder Shaft Dimensions

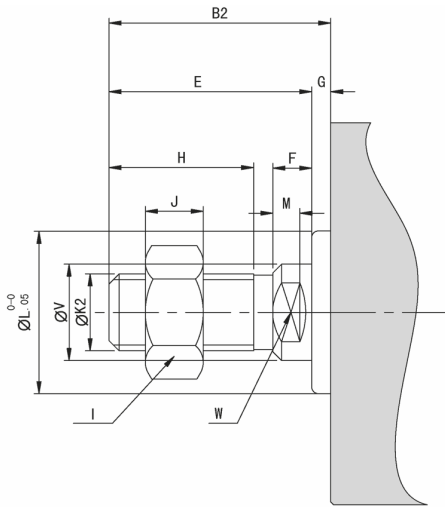

Bore	B2	E	F	G	H	I	J	K2	L	M	V	W
12	17	16	4	1	10	8	4	M5X0.8	10.2	2.8	6	5
16	17.5	16	4	1.5	10	8	4	M5X0.8	11	2.8	6	5
20	20.5	19	4	1.5	13	10	5	M6X1	16	2.8	8	6
25	23	21	4	2	15	12	6	M10X1.25	17	2.8	10	8
32	25	22	4	3	15	17	6	M14X1.5	22	2.8	12	10
40	35	32	4	3	25	19	8	M18X1.5	28	2.8	16	14
50	37	33	5	4	25	27	11	M18X1.5	38	2.8	20	17
63	37	33	5	4	25	27	11	M22X1.5	40	2.8	20	17
80	44	39	6	5	30	32	13	M22X1.5	45	4	25	22
100	50	45	7	5	35	36	13	M26X1.5	55	4	32	27

SSA/STA Series Compact Cylinder Dimensions

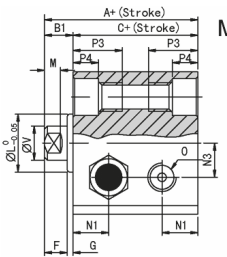

MODEL: SSA12-16

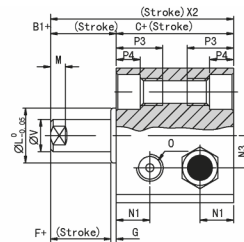
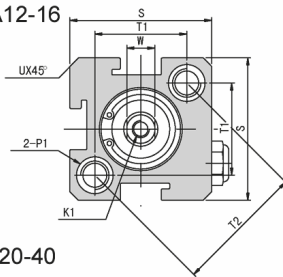

MODEL: STA12-16

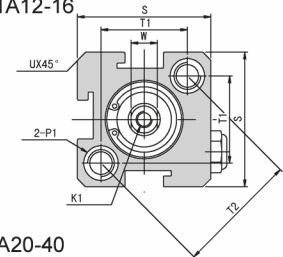

MODEL: SSA20-40

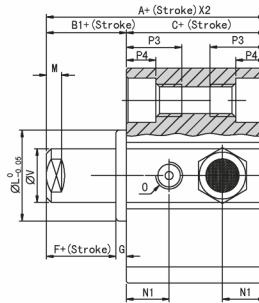
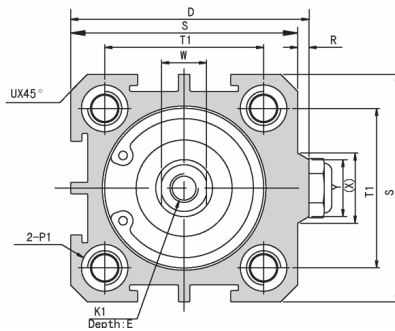
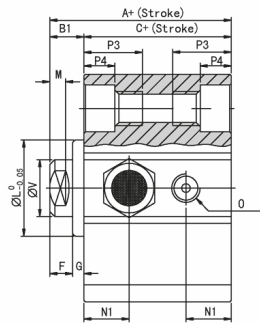

MODEL: STA20-40

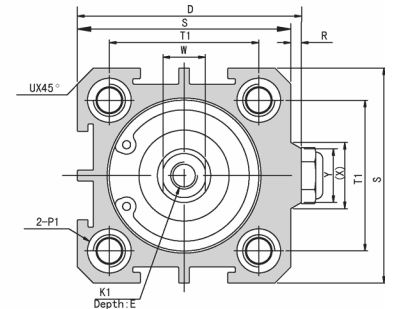

Symbol	Standard Type				With Magnetic Piston																											
	A		C		A		B1		D	E	F	G	K1	L	M	N1	N3	O	P1/Hole Dia.	P3	P4	R	S	T1	T2	U	V	W	X	Y		
Stroke	≤10	>10	≤10	>10	≤10	>10	≤10	>10																								
12	32	42	5	27	37	42	52	5	37	47	-	6	4	1	M3X0.5	10.2	2.8	6.3	6	M5X0.8	M5X0.8X4.2	12	4.5	-	25	16.2	23	1.6	6	5	-	-
16	34	44	5.5	28.5	38.5	44	54	5.5	38.5	48.5	-	6	4	1.5	M3X0.5	11	2.8	7.3	6.5	M5X0.8	M5X0.8X4.2	12	4.5	-	29	19.8	28	1.6	6	5	-	-
20	35	45	5.5	29.5	39.5	45	55	5.5	39.5	49.5	36	8	4	1.5	M4X0.7	16	2.8	7.5	-	M5X0.8	M5X0.8X4.2	14	4.5	2	34	24	-	2.1	8	6	11.3	10
25	37	47	6	34	41	47	57	6	41	51	42	10	4	2	M5X0.8	17	2.8	8	-	M5X0.8	M6X1.0X4.6	15	5.5	2	40	28	-	3.1	10	8	12	10
32	41.5	51.5	7	34.5	44.5	51.5	61.5	7	44.5	54.5	50	12	4	3	M6X1	22	2.8	9	-	1/8	M6X1.0X4.6	16	5.5	6	44	34	-	2.15	12	10	18.3	15
40	43	53	7	36	46	53	63	7	46	56	58.5	12	4	3	M8X1.25	28	2.8	10	-	1/8	M8X1.25X6.5	20	7.5	6.5	52	40	-	2.25	16	14	21.3	16

SEE TOP OF PAGE FOR SHAFT DIMENSIONS

MA/MAL Internal Components

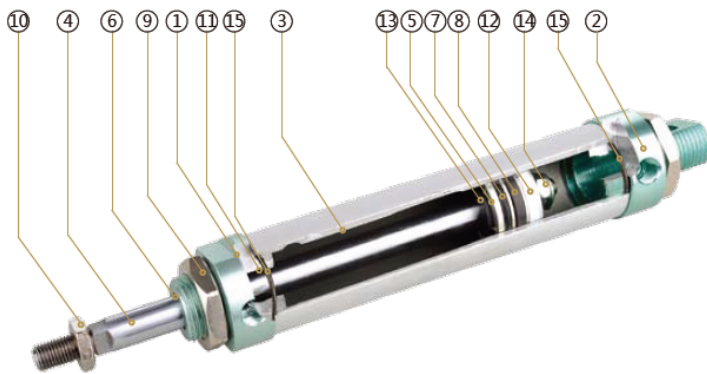

SC/SU Internal Components

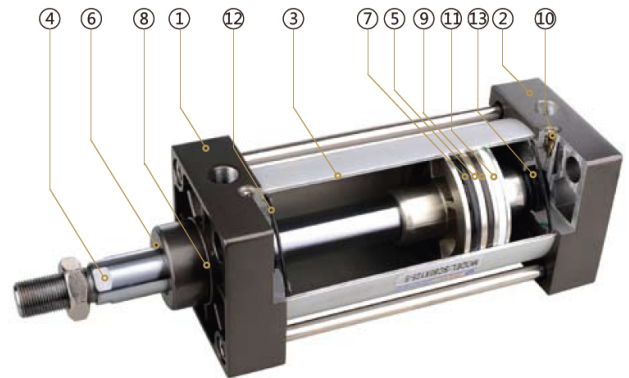

Item	Name	MA Series Cylinder Material	MAL Series Cylinder Material	Quantity
1	Front Cover	Hard Anodized Aluminum	Hard Anodized Aluminum	1
2	Back Cover	Hard Anodized Aluminum	Hard Anodized Aluminum	1
3	Barrel	Stainless Steel	Hard Anodized Aluminum	1
4	Piston Rod	Chromed Carbon Steel	Chromed Carbon Steel	1
5	Piston	Aluminum	Aluminum	1
6	Piston Rod Seal	NBR	NBR	1
7	Piston Seal	NBR	NBR	1
8	Magnet	Ferric Magnet	Ferric Magnet	1
9	Front & Rear Cover	Carbon Steel	Carbon Steel	1
10	Piston Rod Screw	Carbon Steel	Carbon Steel	1
11	Bearing	Non-Lube Bearing	Non-Lube Bearing	1
12	Anti-Friction Ring	PTFE	PTFE	1
13	Cushing Gasket	NBR	NBR	2
14	Fixing Screw	Carbon Steel	Carbon Steel	1
15	Cover Seal	NBR	NBR	2

Item	Name	Material	Quantity
1	Front Cover	Polymer Coated Aluminum	1
2	Back Cover	Polymer Coated Aluminum	1
3	Cylinder Barrel	Anodized Aluminum	1
4	Piston Rod	Chromed Carbon Steel	1
5	Piston	Aluminum	1
6	Piston Rod Seal	NBR	1
7	Piston Seal	NBR	2
8	Bearing	Non-Lube Bearing	1
9	Magnet	Ferric Magnet	1
10	Cushion Screw	Brass	2
11	Anti-Friction Ring	PTFE	1
12	End Cap Seal	NBR	2
13	Cushion Seal	NBR	2

MA/MAL Round Cylinder Technical Data

Bore (mm)	12	16	20	25	32	40
Motion Pattern	Double Action/Single Action					
Working Medium	Air					
Fixed Type	Basic Type/LB Type/FA Type/SDB Type					
Operating Pressure	Double Acting: 14 to 130 PSI (1.0~9.0 bar); Single Acting: 29 to 130 PSI (2.0~9.0 bar)					
Ensured Pressure Resistance	195 PSI (13.5bar)					
Operating Temperature	0 to 70 °C					
Operating Speed	50 ~ 800mm/s					
Buffer Type	Spacer Buffer	Adjustable Buffer (MA and MAL only have spacer buffer)				
Port Size	M5x0.8			G 1/8		G 1/4

SU/SC Cylinder Technical Data

Bore (mm)	32	40	50	63	80	100	125	160	200
Motion Pattern	Double Action								
Working Medium	Air								
Fixed Type	Basic / LB / FA / CA / CB / TC / TC-M Type								
Operating Pressure	14 to 130 PSI (1.0~9.0bar)								
Ensured Pressure Resistance	195 PSI (13.5bar)								
Operating Temperature	0 to 70 °C								
Operating Speed	50 ~ 800mm/s								
Cushioning Length	20			26			45		
Port Size	G 1/8"	G 1/4"		G 3/8"		G 1/2"		G 3/4"	

Terms and Conditions

By purchasing from SIZTO TECH CORPORATION (STC), you agree to these TERMS AND CONDITIONS. No other terms shall apply except as agreed in writing signed by us. We reserve the right to correct typographic errors and reject orders.

SHIPMENTS:

All shipments are F.O.B. 892 Commercial Street, Palo Alto, CA 94303, USA. Most orders are shipped via UPS Standard Ground unless instructions accompany order. Outside the UPS zones, shipment will be made Best Way. The responsibility for goods delay, lost or damaged in transit rests with the carrier and purchaser. Purchaser may purchase shipping insurance to cover lost or damaged products caused by shipping.

RETURN OF MERCHANDISE:

No merchandise is accepted for return 30 days after delivery date. No credit allowed on merchandise shipped as ordered and returned without obtaining an authorization number IN ADVANCE. A 20% restocking charge applies to all returns, and transportation charges must be fully prepaid. We will pay **ground** transportation charges on re-sent or returned merchandise due to STC's error.

Shortages & Mis-Shipments: Any shortages or mis-shipment must be reported within 15 days.

CANCELLATION POLICY:

Blanket orders can be canceled 90 days before scheduled ship date. There will be a 10% charge if a blanket order is cancel within 90 days of scheduled ship date, and a 20% charge if cancel within 60 days. Regular order for non-custom parts can be canceled any time before the order is shipped. For custom parts, a 30% down payment is required either at the time of order or 90 days prior to scheduled ship date, whichever comes later.

Remittances should be sent to:

Sizto Tech Corporation, 892 Commercial Street, Palo Alto, CA 94303, USA

Credit Card Payments: Visa, MasterCard, Discover, or American Express Accepted

International Customers: Advance Payment Required via Bank Wire, Cashier's Check or Approved Credit Card.

Credit Application: To establish a net 30 day account, please mail or fax three trade references with complete mailing addresses and account numbers.

LIMITED WARRANTY – IMPORTANT NOTICE TO PURCHASER:

Sizto Tech Corporation (STC) only warrants this product to be free from defects in materials and workmanship at the time of shipment. This limited warranty expires one year after delivery to the end-user. STC's entire obligation to the Purchaser for breach of this limited warranty shall be limited to replacement of the defective product or refund of the original purchase price of this product, at STC's option. Purchaser has thirty (30) days to return the goods after STC has agreed to accept the return. All freight charges on returned material shall be paid by the Purchaser. STC's limited warranty shall not apply, however, to the product that have been subjected to misuse, alteration, accident or negligence during handling or storage.

DISCLAIMER OF IMPLIED WARRANTIES:

All implied warranties, which may arise by implication of law or application of course of dealing or usage of trade, including, but not limited to, implied warranties of merchantability or fitness for a particular purpose are expressly excluded. There are no warranties, which extend beyond the description of the faced hereof. The end user is solely responsible for the suitability and fitness of this product selected for a particular application.

OBLIGATIONS

You warrant, represent and agree: (1) to comply with all laws; (2) that our sale and shipment of the product will not, by export thereof, your legal status or otherwise, cause us to violate any law; and (3) to indemnify us against any losses from a failure by you or a third party to comply with law or these terms and conditions, or from use of the product.

SAFETY WARNING

Failure or improper selection or improper use of the components and products described herein or related items can cause death, personal injury and/or property damage. This document and other related information from STC provide products options for further investigation by users having the technical expertise. It is important that you analyze all aspects of your application and review the information concerning the component or product in the current catalog. Due to the variety of operation conditions and applications for these components or products, the user, through his own analysis and testing, is solely responsible for making the final selection, installation and maintenance of the products and assuring that all performance, safety and warning requirements of the application are met. All products set-ups and maintenance require the supervision of a qualified individual who is familiar with installation, inspection and testing through training or experience.

IMPORTANT NOTICE:

The products described herein, including without limitation, product features, specifications, design, availability and pricing, are subject to change without notice. We continuously improve the products, and we reserve the right to change specifications without incurring any obligation to incorporate new factors in equipment previously sold.

Distributed By: